



## **K S R Institute for Engineering and Technology**

**Tiruchengode, Namakkal (Dt), Tamil Nadu**

**(Approved by AICTE New Delhi & Affiliated to Anna University Chennai)**

**BE (CSE, EEE, ECE, Mech) & B.Tech (IT) Programmes are Accredited by NBA**

### **5.1.3 Capacity building and skills enhancement initiatives taken by the institution**

#### **ACADEMIC YEAR - 2017-2018**

<b>S.No</b>	<b>Academic year</b>	<b>Page No</b>
<b>1</b>	Soft Skills	02 – 290
<b>2</b>	Language and Communication Skills	291 – 303
<b>3</b>	Life Skills (Yoga, physical fitness, health and hygiene)	304 – 325
<b>4</b>	ICT/Computing skills	326 – 428

# ***1. SOFT SKILLS***

**K S R INSTITUTE FOR ENGINEERING AND TECHNOLOGY  
SOFT SKILLS CONSOLIDATE LIST**

**Academic Year:2017-2018**

S.NO.	Name of the capability enhancement program	Date of implementation (DD-MM-YYYY)	Number of students enrolled	Name of the agencies/consultants involved with contact details (if any)
1	Aptitude Training Programme - I	19.06.2017	322	Internal Maths Faculty
2	Quantitative Aptitude	26.07.2017	264	Six Phrase Training Agency, Six Phrase@gmail.com
3	Quantitative Aptitude	04.08.2017	196	Six Phrase Training Agency, Six Phrase@gmail.com
4	Quantitative Aptitude	31.08.2017	73	Six Phrase Training Agency, Six Phrase@gmail.com
5	Quantitative Aptitude	04.09.2017	260	Six Phrase Training Agency, Six Phrase@gmail.com
6	Quantitative Aptitude	12.09.2017	71	Six Phrase Training Agency, Six Phrase@gmail.com
7	Logical Reasoning, Pseudocode	11.10.2017	53	Six Phrase Training Agency, Six Phrase@gmail.com
8	Aptitude Training Programme - II	11.12.2017	334	Internal Maths Faculty
9	Interaction on Interview Skill and Job Description of the Company	20.12.2017	330	Internal Faculty

  
**PRINCIPAL**  
 PRINCIPAL,  
 K. S. R. INSTITUTE FOR  
 ENGINEERING AND TECHNOLOGY,  
 K. S. R. KALVI NAGAR,  
 TIRUCHENGOORE - 637 215,  
 NAMAKKAL Dt, TAMIL NADU.

**K S R INSTITUTE FOR ENGINEERING AND TECHNOLOGY**  
**Capacity building and skills enhancement initiatives taken by the institution**  
**Academic Year: 2017-18**  
**Soft skills**

S.No	Name of the capacity development and skills enhancement program	Date of implementation	Number of students enrolled	Name of the agencies/consultants involved
1	Interaction on Interview Skill and Job Description of the Company	20.12.2017	All Placement Registered Students	Internal Faculty
2	Aptitude Training Programme - II	11.12.2017	CSE -45 ECE (41+44) - 85, EEE - 52, IT - 44 & MECH (55+53) - 108 Total - 334	Internal English & Maths Faculty
3	Logical Reasoning, Pseudocode	11.10.2017	CSE - 5, ECE - 23, EEE - 19, IT - 6 Total -53	Six Phrase
4	Quantitative Aptitude	12.09.2017	CSE - 7, ECE - 24, EEE - 20, IT - 5 & MECH - 15 Total - 71	Six Phrase
5	Quantitative Aptitude	04.09.2017	CSE - 23, ECE - 62, EEE - 49, IT - 9 & MECH - 117 Total - 260	Six Phrase
6	Quantitative Aptitude	31.08.2017	CSE - 16, ECE - 27, EEE - 23, IT - 7 Total - 73	Six Phrase
7	Quantitative Aptitude	04.08.2017	CSE - 7, ECE - 41, EEE - 26, IT - 5 & MECH - 117 Total - 196	Six Phrase
8	Quantitative Aptitude	26.07.2017	CSE - 23, ECE - 62, EEE - 49, & IT - 11, MECH - 119 Total - 264	Six Phrase
9	Aptitude Training Programme - I	19.06.2017	CSE -47 ECE (42+42) - 84, EEE - 47, IT - 45 & MECH (50+49) - 99 Total - 322	Internal Maths Faculty

PRINCIPAL,  
K. S. R. INSTITUTE FOR  
ENGINEERING AND TECHNOLOGY,  
K. S. R. KALVI NAGAR,  
TIRUCHENGODE-637 215,  
NAMAKKAL Dt. TAMIL NADU.

*P. Venkatesh*  
HoD/EEE

K S R INSTITUTE FOR ENGINEERING AND TECHNOLOGY, TIRUCHENGODE - 637 215

TRAINING AND PLACEMENT CELL

Training Schedule [2017 - 2018] ODD Semester



Ref: KSRIET/T&P/CIR/2017-18

Date: 17.12.2017

This is to inform all the HoDs and department Training and Placement coordinators that the Training Programmes (GD & Resume Preparation Tips, HR Tips, Job Description & Skills required by company) is scheduled for III year students for the academic year 2017 - 2018. All the registered students should attend the Training Programme. If any student skips this Training Programme without proper permission from the respective HoDs, he / she will not be permitted for any further Training Programme and campus recruitment process. Proper Dress Code is mandatory.

Session Timing: 4.30 pm to 6 pm

  
T&P OFFICER

  
T&P COORDINATOR

  
PRINCIPAL

Copy to:

1. All HoDs
2. Notice Board

  
PRINCIPAL,  
K. S. R. INSTITUTE FOR  
ENGINEERING AND TECHNOLOGY,  
K. S. R. KALVI NAGAR,  
TIRUCHENGODE - 637 215,  
NAMAKKAL Dt, TAMIL NADU.

**K S R INSTITUTE FOR ENGINEERING AND TECHNOLOGY, TIRUCHENGODE - 637215**

Training and Placement Cell

3 Days Evening Interaction schedule

Batch: 2015 -2019

Year/ Sem:III / VI

S.No	Date	GD & Resume Tips By Dr.C.Muhuntarajan HoD/English	HR Tips By Dr.R.Nandakumar HoD/ECE	Job Description & Skillset required by Company By T&P Coordinators
1	20.12.2017	Batch NO: 2 CSE & ECE Faculty Venue: ECE Seminar hall	Batch NO: 3 EEE & IT Faculty Venue: EEE Seminar hall	Batch NO: 1 AS - Both - P. Premkumar & M.Jaganathan AS - IT - R. Naresh & Y. Kalimuthu Venue: AS Both - 217 & AS - IT - 202
2	21.12.2017	Batch NO: 3 MECH Faculty Venue: EEE Seminar hall	Batch NO: 1 CSE & ECE Faculty Venue: ECE Seminar hall	Batch NO: 2 IS - Both & IT - R. Naresh & Y. Kalimuthu AS - Core - P. Premkumar & Balamurugan Venue: IS Both & IT - 217 & AS - Core- 211
3	22.12.2017	Batch NO: 1 EEE & IT Faculty Venue: EEE Seminar hall	Batch NO: 2 MECH Faculty Venue: ECE Seminar hall	Batch NO: 3 IS - Core - M Jaganathan, Balamurugan & Ramkumar Venue: IS Core - 217 & 211

**BATCH Details:**

Batch No: 1	AS - Both - 56 (EEE-A:03, EEE-B:10, ECE-A:7, ECE-B:17, Mech-A:06, Mech-B:5, Mech-C:8)
	AS - IT - 35 (CSE:10, IT:15, ECE-A:07, ECE-B:03)
Batch No: 2	IS - Both - 40 (EEE-A:08, EEE-B:10, ECE-A:16, ECE-B:06)
	IS - IT - 27 (CSE:16, IT:09, ECE-B:02)
	AS-CORE - 67 (EEE-A:09, EEE-B:07, ECE-A:03, ECE-B:05, Mech-A:29, Mech-B:09, Mech-C:05)
Batch No:3	IS-CORE - 106 (EEE-A:06, EEE-B:10, ECE-A:04, ECE-B:03, Mech-A:17, Mech-B:32, Mech-C:34)

*Y. Kalimuthu*  
T & P OFFICER

*[Signature]*  
T & P COORDINATOR

PRINCIPAL,  
K. S. R. INSTITUTE FOR  
ENGINEERING AND TECHNOLOGY,  
K. S. R. KALVI NAGAR,  
TIRUCHENGODE - 637 215,  
NANAKKAL DI, TAMIL NADU.

*[Signature]*  
PRINCIPAL

## Training and Placement Cell

Batch 3 - Evening Training Interaction - 20.12.2017 - 22.12.2017

BATCH : 2015 - 2019

Year / Sem: III/ VI

Date	Venue	Perticular	Faculty Incharge
20.12.17	EEE Seminar hall	HR	EEE & IT
21.12.17	EEE Seminar hall	GD & Resume Preparatiom	MECH
22.12.17	IS - Core - 211 & 2017	JD & Skillset	Balamurugan, Jaganathan, Premkumar

S. No	Reg No	Name	Branch	Skill	20.12.17	21.12.17	22.12.17
1	731615106020	GAYATHRI R	ECE - A	IS - CORE	/	①	①
2 /	731615106028	ISWARYA.P	ECE - A	IS - CORE	/	act	act
3	731615106302	PRATHEEP S	ECE - A	IS - CORE	/	①	①
	731615106304	SASIKUMAR T.	ECE - A	IS - CORE	/	①	①
5 /	731615106043	MOVULICA D	ECE - B	IS - CORE	/	/	/
6 /	731615106045	NARESH M	ECE - B	IS - CORE	/	/	/
7 /	731615106082	YOGESH E V	ECE - B	IS - CORE	/	/	/
8 /	731615105047	MADHAN G	EEE B	IS - CORE	/	act	/
9 /	731615105051	MANIKANDAN G	EEE B	IS - CORE	a	a - NI	
10 /	731615105058	NAVEEN M T	EEE B	IS - CORE	P	P	P
11	731615105061	PERUMAL C	EEE B	IS-CORE	a	a - NI/NI	
12 /	731615105064	PRAVEENKUMAR S	EEE B	IS - CORE	a	a	/
13 /	731615105069	RANJITHKUMAR N	EEE B	IS - CORE	/	/	act
14 /	731615105078	SURENDHAR M M	EEE B	IS - CORE	a	a - a	
15	731615105082	THARUN N	EEE B	IS-CORE	a	a	/
16 /	731615105088	YOKESH KANNA K R	EEE B	IS - CORE	/	act	/
17 /	731615105702	GOWTHAM C	EEE B	IS - CORE	/	/	/
18 /	731615105010	DINAHARAN S	EEE A	IS - CORE	a	a - NI	
19 /	731615105013	GOBIKRISHNAN R	EEE A	IS - CORE	/	/	act
20 /	731615105016	GOKUL V	EEE A	IS - CORE	/	/	/
21 /	731615105018	GOKULRAJ B	EEE A	IS - CORE	a	a - NI	a
22 /	731615105024	GOWTHAM V	EEE A	IS - CORE	/	/	/
23 /	731615105027	HARIHARAN N	EEE A	IS - CORE	oi	oi	/
24	731615114006	AKILAN M	MECH - A	IS-CORE	/	/	a
25	731615114007	ALEXANDER M	MECH - A	IS-CORE	/	/	/
26	731615114012	ASHWIN L	MECH - A	IS-CORE	/	/	/
27	731615114015	BALAJI M	MECH - A	IS-CORE	/	/	a
28	731615114017	BALAKRISHNAN C	MECH - A	IS-CORE	/	/	a
29	731615114020	BHARATH P	MECH - A	IS-CORE	/	/	a

S. No	Reg No	Name	Branch	Skill	20.12.17	21.12.17	22.12.17
30	731615114021	BHARATHI K N	MECH - A	IS-CORE	/	/	/
31	731615114022	BHARATH KUMAR S	MECH - A	IS-CORE	/	/	a
32	731615114028	DEVA S	MECH - A	IS-CORE	/	/	/
33	731615114031	DHARANISHANKAR P	MECH - A	IS-CORE	/	/	/
34	731615114043	GIRI K	MECH - A	IS-CORE		/	/
35	731615114046	GOBINATH R	MECH - A	IS-CORE	/	P	FD
36	731615114052	HARIPRASATH S	MECH - A	IS-CORE	/	/	/
37	731615114054	HRITHWIK RAJEEV	MECH - A	IS-CORE	/	/	/
38	731615114055	JACKSON P V	MECH - A	IS-CORE	/	/	/
39	731615114056	JAGADEESH S	MECH - A	IS-CORE	/	/	a
40	731615114301	AJITH M	MECH - A	IS-CORE	/	P	FD
41	731615114062	KARTHICK R	MECH - B	IS-CORE	/	/	/
42	731615114063	KARTHIKEYAN A	MECH - B	IS-CORE	FD	FD	/
43	731615114065	KAVIN KUMAR R	MECH - B	IS-CORE	/	/	/
44	731615114068	KISHORE M	MECH - B	IS-CORE	/	/	/
45	731615114069	KISHORE KUMAR M	MECH - B	IS-CORE	/	/	FD
46	731615114070	KUMAR P	MECH - B	IS-CORE	/	/	/
47	731615114071	LINGESWAR M	MECH - B	IS-CORE	/	/	/
48	731615114074	MADHUSUDHAN R	MECH - B	IS-CORE	/	/	/
49	731615114075	MANIKANDABOOPATHI B	MECH - B	IS-CORE	/	/	/
50	731615114076	MANIKANDAN G	MECH - B	IS-CORE	/	/	/
51	731615114082	MOHAMMED EHIYA S	MECH - B	IS-CORE	/	/	/
52	731615114084	MOHAN PRABHU K	MECH - B	IS-CORE	/	/	/
53	731615114086	NANDHAKUMAR M	MECH - B	IS-CORE	← or P →		
54	731615114087	NANDHAKUMAR S (6/10/97)	MECH - B	IS-CORE	/	P	/
55	731615114088	NANDHAKUMAR S (22/8/98)	MECH - B	IS-CORE	/	/	/
56	731615114089	NARENDHIRAN M	MECH - B	IS-CORE	/	/	/
57	731615114090	NAVANEETHAN R	MECH - B	IS-CORE	/	/	FD
58	731615114095	NAVEEN KUMAR N (6.1.97)	MECH - B	IS-CORE	/	/	/
59	731615114096	NAVEEN KUMAR N (8.6.98)	MECH - B	IS-CORE	/	/	/
60	731615114105	PRINSHITH P	MECH - B	IS-CORE	/	/	/
61	731615114106	PRITAM BHATTACHARYA G	MECH - B	IS-CORE	FD	FD	FD
62	731615114108	PUVIYARASAN N	MECH - B	IS-CORE	/	/	/
63	731615114110	RAJAMANI M	MECH - B	IS-CORE	/	/	/
64	731615114111	RAMANA SARATHI A T	MECH - B	IS-CORE	/	/	/
65	731615114112	RAMESH M	MECH - B	IS-CORE	/	/	/
66	731615114113	RAM KUMAR M	MECH - B	IS-CORE	/	/	/
67	731615114305	DINESH.S	MECH - B	IS-CORE	/	/	/
68	731615114308	V.GOWTHAM	MECH - B	IS-CORE	/	/	/
69	731615114312	K.MAHESHWARAN	MECH - B	IS-CORE	/	/	/

PRINCIPAL,  
K. S. R. INSTITUTE FOR  
ENGINEERING AND TECHNOLOGY,  
K. S. R. KALVI NAGAR,  
TIRUCHENGODE - 637 215,  
NAMAKKAL Dt, TAMIL NADU.



S. No	Reg No	Name	Branch	Skill	20.12.17	21.12.17	22.12.17
70	731615114116	SABARIRAJ D	MECH - C	IS-CORE	/	/	a
71	731615114117	SAI HARISH V	MECH - C	IS-CORE	/	/	/
72	731615114122	SANTHOSH KUMAR M	MECH - C	IS-CORE	/	/	/
73	731615114124	SARAVANAN M	MECH - C	IS-CORE	PD	/	/
74	731615114128	SATHISH KUMAR S	MECH - C	IS-CORE	/	/	/
75	731615114129	SATHISHKUMAR T	MECH - C	IS-CORE	/	/	a
76	731615114131	SELVAKUMAR R	MECH - C	IS-CORE	/	/	a
77	731615114137	SHYAM SUNDAR S	MECH - C	IS-CORE	/	a	a
78	731615114138	SOUNDHIRARAJAN P	MECH - C	IS-CORE	PD	a	a
79	731615114140	SUBHASH S	MECH - C	IS-CORE	/	/	/
80	731615114141	SUDHAKAR R M	MECH - C	IS-CORE	PD	FP	PD
81	731615114142	SUDHARSEN M	MECH - C	IS-CORE	/	/	ED
82	731615114143	SUGAN A	MECH - C	IS-CORE		/	-NT
83	731615114147	SYLESH P	MECH - C	IS-CORE	PD	OD	PD
84	731615114148	TAMILVANAN M	MECH - C	IS-CORE	/	/	/
85	731615114149	THAGAPPILLAI G	MECH - C	IS-CORE	/	/	/
86	731615114151	THAMIL SELVAM S	MECH - C	IS-CORE	/	/	/
87	731615114152	UMANATH G	MECH - C	IS-CORE	/	/	/
88	731615114155	VENGAINAYAGAN K	MECH - C	IS-CORE	PD	PD	PD
89	731615114156	VENKADESAN I	MECH - C	IS-CORE	/	/	/
90	731615114157	VENUGOPAL P	MECH - C	IS-CORE	/	/	/
91	731615114160	VIGNESH S (01.04.1998)	MECH - C	IS-CORE	/	/	/
92	731615114161	VIJAY M	MECH - C	IS-CORE	/	/	/
93	731615114163	VIMALRAJ R	MECH - C	IS-CORE	/	/	/
94	731615114164	VINOTH KUMAR P	MECH - C	IS-CORE	/	/	PD
95	731615114166	YOGESH K	MECH - C	IS-CORE	/	/	/
96	731615114314	NETHAJI M	MECH - C	IS-CORE	/	/	/
97	731615114317	RADHAKRISHNAN M	MECH - C	IS-CORE	PD	a	a
98	731615114319	REVENTHKUMAR S	MECH - C	IS-CORE	/	/	PD
99	731615114321	SENGOTAIYAN R	MECH - C	IS-CORE	/	/	/
100	731615114322	SUNILRAJ C	MECH - C	IS-CORE	/	/	/
101	731615114323	THIRU MOORTHY B	MECH - C	IS-CORE	/	/	/
102	731615114701	NAVANEETHA KRISHNAN M	MECH - C	IS-CORE		/	/
103	731615114092	NAVEEN M (20/6/97)	MECH - B	IS-CORE			/
104	731615114097	NISHANTHI E	MECH - B	IS-CORE			
105	731615114102	PRAKASH R	MECH - B	IS-CORE			
106	731615114139	SRIDHAR L	MECH - C	IS-CORE			
<b>Present</b>							
<b>Absent</b>							
<b>OD</b>							
<b>Leave</b>							

97- Nishanthi

PRINCIPAL,  
 K. S. R. INSTITUTE FOR  
 ENGINEERING AND TECHNOLOGY,  
 K. S. R. KALVI NAGAR,  
 TIRUCHENGODE - 637 215,  
 NAMAKKAL Dt, TAMIL NADU.

Date	Venue	Perticular	Faculty Incharge
20.12.17	ECE Seminar Hall	GD & Resume Preparatiom	CSE & ECE
21.12.17	IS - Both - 217 AS - Core - 211	JD & Skillset	AS - Core: Premkumar & Balamurugan IS -Both & IT: R. Naresh & Y. Kalimuthu
22.12.7	EEE Seminar hall	HR	MECH

S. No	Reg No	Name	Branch	Skill	20.12.17	21.12.17	22.12.17
1	731615104001	AARTHI R	CSE	LS - IT	NI	/	P
2	731615104002	AJITH KUMAR P	CSE	LS - IT	a	a	a
3	731615104008	DINESH J	CSE	LS - IT	/	/	/
4	731615104009	ELAKKIYA T.E	CSE	LS - IT	a	a	NI
5	731615104010	GOKUL K	CSE	LS - IT	/	/	/
6	731615104018	MEIYEAPPAN M	CSE	LS - IT	/	/	/
7	731615104021	NAVEENA D	CSE	LS - IT	NI	NI	NI
8	731615104026	PRADEEPKUMAR R	CSE	LS - IT	a	a	a
9	731615104027	PRASANTH RAJA (10/06/1997)	CSE	LS - IT	/	/	/
10	731615104031	RAJAGANAPATHY T	CSE	LS - IT	/	/	PP
11	731615104032	SABANA YASMINE A	CSE	LS - IT	NI	NI	NI
12	731615104034	SARANYA S	CSE	LS - IT	NI	NI	NI
13	731615104036	SHALINI S	CSE	LS - IT	/	/	OD
14	731615104037	SHARTHAI BANU D	CSE	LS - IT	NI	NI	NI
15	731615104044	VINOTHA V	CSE	LS - IT	NI	NI	NI
16	731615104701	KAVIN D	CSE	LS - IT	/	/	/
17	731615205005	ARAVIND KUMAR.V <del>AS-IT</del>	IT	LS - IT	/	/	a
18	731615205008	BALAJI.S	IT	LS - IT	a	a	a
19	731615205014	DHARANI.P AS-IT	IT	LS - IT	/	/	/
20	731615205017	ELANGO VAN.P	IT	LS - IT	/	/	/
21	731615205019	ELANKANEI.M AS-IT	IT	LS - IT	/	/	/
22	731615205031	RAMESH.A	IT	LS - IT	/	/	P
23	731615205035	RINESH.R	IT	LS - IT	/	/	P
24	731615205037	SELVAKUMAR.B	IT	LS - IT	P	/	P
25	731615205039	SUNDARAMOORTHIG	IT	LS - IT	OD	a	OD
26	731615106001	ALEXRAJ.A	ECE - A	AS - CORE	/	/	/
27	731615106002	ANBARASAN.S	ECE - A	IS - BOTH	/	/	/
28	731615106003	ARUNKUMAR.A	ECE - A	IS - BOTH	/	/	/

S. No	Reg No	Name	Branch	Skill	20.12.17	21.12.17	22.12.17
29	731615106005	BALAJI.S	ECE - A	IS - BOTH	a	/	/
30	731615106006	BHARATHI.D	ECE - A	IS - BOTH	/	/	CB
31	731615106007	BHUVANESWARAN.S.M	ECE - A	IS - BOTH	/	/	/
32	731615106015	DHIVYA.M	ECE - A	IS - BOTH	/	/	/
33	731615106016	DIVYA.S	ECE - A	IS - BOTH	/	/	/
34	731615106021	GIRITHARAN.L	ECE - A	IS - BOTH	/	/	/
35	731615106023	GOPALAKRISHNAN.R	ECE - A	IS - BOTH	/	/	/
36	731615106027	HEMALATHA.T	ECE - A	IS - BOTH	/	/	/
37	731615106031	KALAISELVAN.G	ECE - A	IS - BOTH	/	/	/
38	731615106032	KARTHIKA.D	ECE - A	IS - BOTH	/	/	/
39 /	731615106033	KARTHIKEYAN.P	ECE - A	AS - CORE	CB	CB	CB
40	731615106034	KARTHIKEYAN.S	ECE - A	IS - BOTH	CB	a	CB
41 /	731615106035	KATHIRAVAN.M	ECE - A	AS - CORE	/	/	/
42	731615106037	KEERTHANAL	ECE - A	IS - BOTH	/	/	/
43	731615106303	RAMKUMAR L	ECE - A	IS - BOTH	/	/	/
44 /	731615106010	CHANDRA BOSE.S	ECE - A	IS - BOTH	How	.	—
45	731615106039	KEERTHANA S	ECE - B	IS - BOTH	N'	NI	NI
46 /	731615106047	NAVEEN KANNAN S	ECE - B	AS - CORE	CB	CB	NI
47	731615106049	NIVETHA K	ECE - B	IS - BOTH	/	/	/
48 /	731615106052	PALANIVELU G	ECE - B	AS - CORE	/	/	a
49 /	731615106055	PRABHU B	ECE - B	AS - CORE	CB	NI	NI
50 /	731615106056	PRADHIP R R	ECE - B	AS - CORE	a	NI	CB
51	731615106061	PRIYANGA S	ECE - B	IS - IT	/	a	/
52 /	731615106062	RAMESH S	ECE - B	AS - CORE	/	CB	/
53	731615106064	RANJITHRAJA M	ECE - B	IS - IT	/	/	/
54	731615106065	SAKTHIVEL K	ECE - B	IS - BOTH	/	/	/
55	731615106070	SOWMIYA C	ECE - B	IS - BOTH	/	/	/
56	731615106071	SRIDHAR C	ECE - B	IS - BOTH	/	/	/
57	731615106072	SRIDHARAN S	ECE - B	IS - BOTH	How	How	—
58	731615105046	LOHESH J	EEE B	IS - BOTH	/	/	/
59 /	731615105052	MANOJ KUMAR R	EEE B	AS - CORE	/	/	/
60	731615105053	MOHAMMEDRIYAS A	EEE B	IS - BOTH	/	/	/
61	731615105055	MONISHA V	EEE B	IS - BOTH	/	/	/
62 /	731615105056	MOUNISHA S	EEE B	AS - CORE	/	/	/
63	731615105059	NAVEEN KUMAR S	EEE B	IS - BOTH	/	/	/
64	731615105062	POOJA R	EEE B	AS-CORE	/	/	/
65	731615105063	PRAVEENKUMAR B	EEE B	AS-CORE	/	/	/
66	731615105066	RAJASEKAR P V	EEE B	IS - BOTH	/	/	/
67	731615105067	RAMESH S R	EEE B	IS - BOTH	/	/	/
68	731615105070	RAVI A	EEE B	AS - CORE	CB	CB	CB

PRINCIPAL,  
K. S. R. INSTITUTE FOR  
ENGINEERING AND TECHNOLOGY,  
K. S. R. KALVI NAGAR,  
TRUCHENGODE - 637 215,  
KANNIYAKAL DE, TAMIL NADU.

S. No	Reg No	Name	Branch	Skill	20.12.17	21.12.17	22.12.17
69	731615105072	SEKAR S	EEE B	IS - BOTH	/	a	/
70	731615105079	SWATHI R	EEE B	IS - BOTH	/	/	/
71 /	731615105080	SWATHI S	EEE B	AS - CORE	/	a	/
72 /	731615105081	TAMILSELVAN M	EEE B	AS - CORE	/	a	/
73	731615105084	VEERA KUMAR B	EEE B	IS - BOTH	a	P	NI
74	731615105085	VISHNU R	EEE B	IS - BOTH	/	/	/
75	731615105004	CATHRINAL J	EEE A	AS-CORE	Acad	---	---
76	731615105005	CHIDAMBARAM V	EEE A	IS - BOTH	/	/	/
77	731615105007	DHIVAGAR N	EEE A	IS - BOTH	/	/	/
78	731615105008	DHIVAGAR S	EEE A	IS - BOTH	/	/	/
79 /	731615105009	DICKMAN PIOUS P	EEE A	AS - CORE	a	a	/
80	731615105012	GAYATHRI K	EEE A	IS - BOTH	/	/	/
81 /	731615105021	GOWSALYA A	EEE A	AS - CORE	/	a	/
82 /	731615105023	GOWTHAM S	EEE A	AS - CORE	/	P	P
83 /	731615105026	HARIHARAN G	EEE A	AS - CORE	/	a	/
84	731615105029	HARINI S	EEE A	IS - BOTH	/	/	/
85 /	731615105030	JANANI R	EEE A	AS - CORE	/	a	/
86 /	731615105034	KALAICHELVI V	EEE A	AS - CORE	/	a	/
87	731615105035	KANNAN S	EEE A	IS - BOTH	/	/	/
88	731615105039	KEERTHIKA C	EEE A	IS - BOTH	/	/	/
89 /	731615105041	KODEESWARI M	EEE A	AS - CORE	CL	CL	CL
90 /	731615105043	KOWSALYA K	EEE A	AS - CORE	/	a	NI
91	731615105044	KRISHNAMOORTHIS	EEE A	IS - BOTH	/	/	/
92	731615114004	AJITHKUMAR S	MECH - A	AS-CORE	/	a	/
93	731615114005	AJITH KUMAR S	MECH - A	AS-CORE	/	a	/
94	731615114010	ARAVINTHASAMY B	MECH - A	AS-CORE	/	a	/
95	731615114018	BALAKUMAR A	MECH - A	AS-CORE	/	a	a
96	731615114019	BENAZIR U	MECH - A	AS-CORE	/	/	a
97	731615114024	BOOPATHIRAJA S	MECH - A	AS-CORE	/	/	/
98	731615114027	DEENADHAYALAN P	MECH - A	AS-CORE	/	/	/
99	731615114029	DHANASEKAR R	MECH - A	AS-CORE	/	/	/
100	731615114032	DHINESH S	MECH - A	AS-CORE	/	/	/
101 /	731615114033	DHINESHRAJ L	MECH - A	AS - CORE	/	/	/
102	731615114034	DINESH J	MECH - A	AS-CORE	/	/	/
103	731615114037	DINESHKUMAR B	MECH - A	AS-CORE	/	/	/
104	731615114039	DUDIARASU S	MECH - A	AS-CORE	/	a	a
105 /	731615114042	GABY SACHIN S	MECH - A	AS - CORE	/	/	/
106 /	731615114044	GIRIDHARAN B	MECH - A	AS - CORE	/	/	/
107	731615114049	GOKULRAJ V	MECH - A	AS-CORE	/	/	a
108	731615114050	GOPIKA R	MECH - A	AS-CORE	/	/	a

PRINCIPAL,  
K. S. R. INSTITUTE FOR  
ENGINEERING AND TECHNOLOGY,  
K. S. R. KALVI NAGAR,  
TIRUCHENGODE - 637 215,  
NAMAIKAL DI, TAMIL NADU.

S.No	Reg No	Name	Branch	Skill	20.12.17	21.12.17	22.12.17
109	731615114051	GOWTHAM K	MECH - A	AS-CORE	/	/	/
110	731615114053	HARIRAJ K	MECH - A	AS - CORE	/	/	a
111	731615114058	JAGADESHWARAN S	MECH - A	AS-CORE	/	/	/
112	731615114302	ARUN AKASH S	MECH - A	AS-CORE	/	/	/
113	731615114072	LOGANATHAN K	MECH - B	AS-CORE	2	/	/
114	731615114073	MADHAN KUMAR M	MECH - B	AS-CORE	/	/	/
115	731615114091	NAVEEN M (20/3/97)	MECH - B	AS-CORE	a	a	a
116	731615114093	NAVEEN N	MECH - B	AS-CORE	/	/	/
117	731615114094	NAVEEN KUMAR B	MECH - B	AS-CORE	/	/	/
118	731615114100	OM ADHAVAN B	MECH - B	AS-CORE	/	/	/
119	731615114109	RAGU S	MECH - B	AS-CORE	/	/	a
120	731615114115	ROBERT SAM DANIEL	MECH - B	AS-CORE	/	/	/
121	731615114309	KARTHIK .G	MECH - B	AS-CORE	/	/	/
122	731615114133	SHANKAR K	MECH - C	AS-CORE	/	/	/
123	731615114135	SHREERAM M R	MECH - C	AS-CORE	/	/	/
124	731615114136	SHUKEL AHAMED M	MECH - C	AS-CORE	/	/	/
125	731615114153	VASANTHAKUMAR B	MECH - C	AS-CORE	a	a	a
126	731615114002	AJITH K S	MECH - A	AS-CORE	P	P	.
127	731615114003	AJITH V	MECH - A	AS-CORE	R	P	.
128	731615114014	BALAJI M	MECH - A	AS-CORE	R	P	.
129	731615114016	BALAJI RAM G	MECH - A	AS-CORE	P	P	.
130	731615114023	BHUVANESHWARAN S	MECH - A	AS-CORE	P	P	.
131	731615114045	GNANA PRAKASH A S	MECH - A	AS-CORE	P	P	.
132	731615114047	GOKUL P	MECH - A	AS-CORE	R	P	.
133	731615114048	GOKUL MAYURA PRIYAN B	MECH - A	AS-CORE	R	P	.
Present							
Absent							
Permission							

ECE  
S. Pradeep - AS-CORE  
Sharan Kumar - "  
ECE  
T. Sasi Kumar - "

21/12  
Saranya . M Ece - 15-17  
Pravitha . R Ece - 15-17  
Apleepriya . M Ece - 15-17  
Mayathir R Ece - 15-17  
Bivya . S Ece - 15-17  
Prathap . S nivedhan Raj  
T. Sasi Kumar

9  
3  
9  
9  
15 → Lakshmi - AS CORE  
15 → Anitharan - AS CORE

Tot no of stu  
AS - 81 - 14 - 6  
DS 67 16 - 4  
I - 64  
26 - 96 14 - 7  
AS CORE 58 15 - 4

PRINCIPAL,  
K. S. R. INSTITUTE FOR  
ENGINEERING AND TECHNOLOGY,  
K. S. R. KALVI NAGAR,  
TRUCHINGODE - 637 215,  
NAMAKKAL, TAMIL NADU.

MECH - 199  
CSE -  
17-23  
EEB-61  
FEB-62

## Training and Placement Cell

Batch 1 - Evening Training Interaction - 20.12.2017 - 22.12.2017

BATCH : 2015 - 2019

Year / Sem: III/ VI

Date	Venue	Content	Faculty Incharge
20.12.17	AS - Both - 217 AS - IT - 202	JD & Skillset	AS - Both: Premkumar & M Jaganathan AS - IT: R. Naresh & Y. Kalimuthu
21.12.17	ECE Seminar Hall	HR	CSE & IT
22.12.7	EEE Seminar hall	GD & Resume Preparatiom	EEE & IT

S. No	Reg No	Name	Branch	Skill	20.12.17	21.12.17	22.12.17
1	731615104005	BALAJI M	CSE	AS_IT	/	/	/
2	731615104007	BOOPATHIRAJA M	CSE	AS_IT	/	/	/
3	731615104012	GUNA BHARATHI T	CSE	AS_IT	/	/	ED
4	731615104016	KIRUBHANANDHAN P	CSE	AS_IT	/	✓	/
5	731615104019	MOHANRAJ C	CSE	AS_IT	/	WS	/
6	731615104023	NISHA S	CSE	AS_IT	/	/	/
7	731615104025	PAVITHRA E	CSE	AS_IT	/	/	ED
8	731615104029	PRAVEEN G	CSE	AS_IT	/	/	/
9	731615104030	PRIYADHARSHINI R	CSE	AS_IT	/	/	/
10	731615104033	SAKTHIVEL E	CSE	AS_IT	/	/	/
11	731615205001	ABHITH JOHN ANTO.K	IT	AS - IT	o.w/s	/	/
12	731615205002	AISWARYA.R	IT	AS-IT	/	/	a
13	731615205006	ARUNKUMAR.R	IT	AS-IT	/	/	/
14	731615205011	DENMOZHIS	IT	AS-IT	/	/	/
15	731615205012	DHANUSYADEVLS	IT	AS-IT	/	/	/
6	731615205016	DIVYA.R	IT	AS-IT	/	/	/
17	731615205018	ELANGOVAN.S	IT	AS - IT	/	/	/
18	731615205021	GOWSIKKANNAN.V	IT	AS - IT	/	/	/
19	731615205022	GOWTHAM.R	IT	AS-IT	NI	NI	NI
20	731615205023	HEMALATHA.G	IT	AS-IT	/	/	/
21	731615205026	MANOJKUMAR.D	IT	AS - IT	/	/	ED
22	731615205029	PRIYANKA.S	IT	AS-IT	/	/	/
23	731615205036	SARAVANAPRIYA R	IT	AS-IT	/	/	/
24	731615205038	SNEKA D	IT	AS-IT	/	/	/
25	731615205040	THIRUMALAIRAJAN.K	IT	AS-IT	/	ED	ED
26	731615106009	BHUVANESWARI.R	ECE - A	AS - IT	/	/	/
27	731615106012	DEVI.U	ECE - A	AS - BOTH	/	/	/
28	731615106013	DHARANIR	ECE - A	AS - BOTH	/	/	/
29	731615106014	DHAYALI.G	ECE - A	AS - BOTH	/	/	/

PRINCIPAL,  
K. S. R. INSTITUTE FOR  
ENGINEERING AND TECHNOLOGY,  
K. S. R. KALVI NAGAR,  
TIRUCHENGODE - 637 215,  
NAMAKKAL Dt, TAMIL NADU.

S. No	Reg No	Name	Branch	Skill	20.12.17	21.12.17	22.12.17	
30	731615106017	DIVYA.S	IS Both	ECE - A	AS - BOTH	/	(1)	(1)
31	731615106018	EZHILM		ECE - A	AS - IT	/	/	/
32	731615106022	GOKILA.T	AS - IT	ECE - A	AS - BOTH	/	/	/
33	731615106024	GOWRI.P		ECE - A	AS - IT	/	el	/
34	731615106025	HARINI.T		ECE - A	AS - IT	/	/	/
35	731615106026	HARSHINI DEVI.P		ECE - A	AS - IT	/	/	/
36	731615106029	JAYABHARATHI.S	AS - IT	ECE - A	AS - BOTH	/	/	/
37	731615106036	KAVIPREETHI.V	AS - IT	ECE - A	AS - BOTH	/	/	/
38	731615106039	KOKILA.R		ECE - A	AS - IT	/	/	/
39	731615106041	KOWSALYA.C		ECE - A	AS - IT	/	/	/
40 /	731615106042	LOGAPRIYA M	IS - Both	ECE - B	AS - BOTH	/	(1)	(1)
41	731615106046	NAVEEN T S		ECE - B	AS - IT	OD	/	/
42	731615106050	NIVETHAN RAJ C		ECE - B	AS - BOTH	/	CR	(1)
43 /	731615106053	PAVITHRA R	IS - Both	ECE - B	AS - BOTH	01	(1)	(1)
44	731615106054	PAVITHRA P		ECE - B	AS - BOTH	/	/	/
45	731615106057	PRAVEENKUMAR V	AS - IT	ECE - B	AS - BOTH	/	/	/
46	731615106059	PRIYADHARSHINI S		ECE - B	AS - BOTH	/	/	/
47	731615106063	RAMYA B		ECE - B	AS - BOTH	NI	NE	NI
48	731615106067	SARASWATHI P		ECE - B	AS - BOTH	/	/	/
49	731615106069	SELVARAKESHKUMAR C		ECE - B	AS - BOTH	/	/	/
50	731615106073	SUGANTHI S		ECE - B	AS - BOTH	/	/	/
51	731615106074	TAMILARASI J		ECE - B	AS - BOTH	/	/	/
52	731615106076	THARUNYA S		ECE - B	AS - BOTH	Col	/	/
53	731615106077	UMA MAHESHWARI M		ECE - B	AS - BOTH	/	/	/
54	731615106078	VINAY V		ECE - B	AS - BOTH	/	/	/
55	731615106079	VINOTHINI G		ECE - B	AS - BOTH	/	/	/
56 /	731615106701	MAHESWARI C		ECE - B	AS - IT	NI	NI	NI
57	731615106066	SARANYA M		ECE - B	AS - IT		(1)	(1)
58	731615106068	SARAVANAKUMAR R		ECE - B	AS - BOTH			
59	731615106080	VINOTHKUMA M		ECE - B	AS - BOTH			
60	731615105049	MAHAESWARI A		EEE B	AS - BOTH	/	/	/
61	731615105057	MURUGANANTH M		EEE B	AS - BOTH	OD	OD	/
62	731615105065	PRIYADHARSHINI S		EEE B	AS - BOTH	/	/	/
63	731615105071	SATHISH KUMAR M		EEE B	AS - BOTH	/	/	/
64	731615105073	SOUNDHARYA S		EEE B	AS - BOTH	/	/	/
65	731615105075	SRINITHI G		EEE B	AS - BOTH	/	/	/
66	731615105076	SRINIVASAN R		EEE B	AS - BOTH	OD	OD	/
67	731615105077	STEPHEN IMMANUVEL J		EEE B	AS - BOTH	OD	OD	/
68	731615105086	YOGAPRIYA S		EEE B	AS - BOTH	Col	/	/
69	731615105087	YOGESHWARAN S		EEE B	AS - BOTH	Pe	/	/
70	731615105002	ARUNKUMAR C		EEE A	AS - BOTH	OD	OD	/
71	731615105011	ELANCHEZHIAN P		EEE A	AS - BOTH	OD	OD	/

PRINCIPAL,  
K. S. R. INSTITUTE FOR  
ENGINEERING AND TECHNOLOGY,  
K. S. R. KALVI NAGAR,  
TIRUCHENGODE - 637 215,  
NAMAKKAL Dt, TAMIL NADU.

S. No	Reg No	Name	Branch	Skill	20.12.17	21.12.17	22.12.17
72	731615105033	JEEVAPRAKASH V	EEE A	AS - BOTH	/	/	/
73	731615114001	ADHISHANKARAN D	MECH - A	AS-BOTH	a	a	a
74	731615114009	ARAVINTHAN P V	MECH - A	AS-BOTH	/	/	/
75	731615114057	JAGADEESHBABU K	MECH - A	AS-BOTH	/	/	/
76	731615114098	NISHANTHI B	MECH - A	AS-BOTH	Catia	Catia	.
77	731615114067	KESAVARAJ M	MECH - B	AS-BOTH	✓ /	/	/
78	731615114077	MANIKANDAN P	MECH - B	AS-BOTH	/	/	/
79	731615114080	MANOJKUMAR P R	MECH - B	AS-BOTH	/	/	/
80	731615114083	MOHAN KUMAR R	MECH - B	AS-BOTH	/	/	/
81	731615114120	SANTHOSH K	MECH - C	AS-BOTH	✓ /	/	/
82	731615114123	SANTHOSH KUMAR R	MECH - C	AS-BOTH	✓ /	/	/
83	731615114146	SURYA S C	MECH - C	AS-BOTH	OD	OD	.
84	731615114158	VIGNESH M	MECH - C	AS-BOTH	OD	OD	.
85	731615114162	VIJAY P	MECH - C	AS-BOTH	/	/	/
86	731615114313	NAVEEN A	MECH - C	AS-BOTH	✓ /	/	/
87	731615114316	PRAVINTH .K.	MECH - C	AS-BOTH	/	/	/
88	731615114318	RANJITHKUMAR .M	MECH - C	AS-BOTH	/	/	/
89	731615114025	CELLAKAMALALAKSHMI R	MECH - A	AS-BOTH	Catia	Catia	.
90	731615114038	DINESHKUMAR T	MECH - A	AS-BOTH	Catia	Catia	.
91	731615114066	KAVIPRIYAN S	MECH - B	AS-BOTH	Catia	ab	.
<b>Present</b>							
<b>Absent</b>							
<b>Permission</b>							

IT                      20.12.17                      21/12/17                      22/12/17

Elangani                      ✓                      ✓                      ✓

P. Bharani                      ✓                      ✓                      ✓

ECE

Kavi prathi                      -

Jaya Bharathi                      -

Gokila                      -

Praveen Kumar                      -

  
**PRINCIPAL,**  
**K. S. R. INSTITUTE FOR**  
**ENGINEERING AND TECHNOLOGY,**  
**K. S. R. KALVI NAGAR,**  
**TIRUCHENGODE - 637 215,**  
**NAMAKKAL Dt, TAMIL NADU.**



**K S R INSTITUTE FOR ENGINEERING AND TECHNOLOGY**

**TIRUCHENGODE-637215**

**TRAINING AND PLACEMENT CELL**

**Training Programme [2017 – 2018] Even Semester**



**Ref: KSRIET/T&P/CIR/2017-18**

**Date: 07.12.2017**

This is to inform all the HoDs and Faculty members that the 6 days Internal Training on Aptitude & Basic Grammar and Soft Skills for II year students (11.12.2017 to 16.12.2017) during the academic year 2017 – 2018 (Even Semester) has been scheduled. In this regard all the Department Placement Coordinators kindly share the details to the students for smooth conduction of Training Programmes. If any student skips the Training Programme without proper permission from the respective HoDs, he / she will not be permitted for any future Training Programme and campus recruitment process. Proper Dress Code is mandatory.

**Encl.**

Training venue and batch wise topics details.

  
**T&P OFFICER**

  
**T&P COORDINATOR**

  
**PRINCIPAL**

**Copy to:**

1. All HoDs
2. Notice Board

**Session Timings:**

**Forenoon Session: 09:00am – 12:30 pm**

**Afternoon Session: 01:15pm – 04:15 pm**

**Break: 10.45 am to 11.00 am**

**Lunch: 12.30 pm to 01.15 pm**

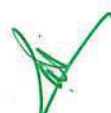
  
**PRINCIPAL,  
K. S. R. INSTITUTE FOR  
ENGINEERING AND TECHNOLOGY,  
K. S. R. KALVI NAGAR,  
TIRUCHENGODE - 637 215,  
NAMBARKAL DI, TAMIL NADU.**

**K S R INSTITUTE FOR ENGINEERING AND TECHNOLOGY**  
**TRAINING AND PLACEMENT CELL**



**3-Day Training Schedule on Aptitude & Basic Grammar and Soft Skills for II-Year Students (2016-2020 Batch)**

Batch / Hall No	11.12.17		12.12.17		13.12.17		14.12.17		15.12.17		16.12.17	
	FN	AN	FN	AN	FN	AN	FN	AN	FN	AN	FN	AN
Batch 1 Hall -101 Strength-46	CS (CM) Module 1	CS (SM) Module 2	CS (PM) Module 3	CS (RK) Module 4	CS (RK) Module 5	CS ASSESSMENT (SM)	APT (AJK) Partnership	APT (NK) BR	APT (KS) P&C	APT (RKV) PA	APT (PS) C&C	APTITUDE ASSESSMENT (RK)
Batch 2 Hall - 208 Strength-46	APT (AJK) Partnership	APT (KS) P&C	APT (PS) C&C	APT (RKV) PA	APT (NK) BR	APTITUDE ASSESSMENT (RK)	CS (CM) Module 1	CS (RK) Module 4	CS (PM) Module 3	CS (SM) Module 2	CS (PM) Module 5	CS ASSESSMENT (SM)
Batch 3 Hall - 102 Strength-46	CS (SM) Module 2	CS (PM) Module 3	CS (RK) Module 4	CS (CM) Module 1	CS (SM) Module 5	CS ASSESSMENT (PM)	APT (RKV) PA	APT (RK) C&C	APT (AJK) Partnership	APT (NK) BR	APT (KS) P&C	APTITUDE ASSESSMENT (KS)
Batch 4 Hall - 209 Strength-46	APT (PS) C&C	APT (RKV) PA	APT (AJK) Partnership	APT (NK) BR	APT (KS) P&C	APTITUDE ASSESSMENT (PS)	CS (SM) Module 2	CS (CM) Module 1	CS (RK) Module 4	CS (PM) Module 3	CS (RK) Module 5	CS ASSESSMENT (PM)
Batch 5 Hall - 109 Strength-46	CS (PM) Module 3	CS (RK) Module 4	CS (CM) Module 1	CS (SM) Module 2	CS (PM) Module 5	CS ASSESSMENT (RK)	APT (NK) C&C	APT (RKV) PA	APT (PS) BR	APT (KS) P&C	APT (AJK) Partnership	APTITUDE ASSESSMENT (RKV)
Batch 6 Hall - 211 Strength-46	APT (NK) BR	APT (PS) C&C	APT (RKV) PA	APT (KS) P&C	APT (AJK) Partnership	APTITUDE ASSESSMENT (NK)	CS (PM) Module 3	CS (SM) Module 2	CS (SM) Module 1	CS (RK) Module 4	CS (TV) Module 5	CS ASSESSMENT (RK)
Batch 7 Hall - 112 Strength-46	CS (RK) Module 4	CS (TV) Module 5	CS (SM) Module 2	CS (PM) Module 3	CS (CM) Module 1	CS ASSESSMENT (CM)	APT (RK) C&C	APT (KS) P&C	APT (RKV) PA	APT (AJK) Partnership	APT (NK) BR	APTITUDE ASSESSMENT (PS)

*[Signature]*  
T&P COORDINATOR

*[Signature]*  
**PRINCIPAL,**  
**K. S. R. INSTITUTE FOR**  
**ENGINEERING AND TECHNOLOGY,**  
**K. S. R. KALVI NAGAR,**  
**TIRUCHENGOODE - 637 215,**  
**NAGARJAL DI, TAMIL NADU.**

*[Signature]*  
PRINCIPAL

Training and Placement Cell - CSE

3-Day Training Schedule on Aptitude & Basic Grammar and Soft Skills Attendance

BATCH : 2016 - 2020

Academic Year: 2017 - 2018

Year / Sem: II / IV

Staff Incharge:

S. No	Name	Branch	Batch No	Hall No	11.12.17				12.12.17				13.12.17				14.12.17				15.12.17				16.12.17			
					FN	FN	AN	AN	FN	FN	AN	AN	FN	FN	AN	AN	FN	FN	AN	AN	FN	FN	AN	AN	FN	FN	AN	AN
1	VASU MITHA R S	CSE	B - I	101	0	0	0	0	/	/	/	/	/	/	/	/	/	/	/	/	/	/	/	/	/	/	/	/
2	VELU PRABHA S	CSE	B - I	101	/	/	/	/	/	/	/	/	0	0	0	0	/	/	/	/	/	/	/	/	/	/	/	/
3	STELIN BERCIA S	CSE	B - I	101	/	/	/	/	0	0	0	0	/	/	/	/	/	/	/	/	/	/	/	0	0	0	0	0
4	SWETHA C	CSE	B - I	101	/	/	/	/	/	/	/	/	/	/	/	/	/	/	0	0	0	0	/	/	/	/	/	/
5	SWETHA B	CSE	B - I	101	/	/	/	/	/	/	/	/	/	/	/	/	/	/	/	/	/	/	/	/	/	/	/	/
6	DEVI GAYATHRI S	CSE	B - I	101	0	0	0	0	/	/	/	/	/	/	/	/	/	/	/	/	/	/	/	/	/	/	/	/
7	MANJULA R	CSE	B - II	208	/	/	/	/	/	/	/	/	/	0	0	0	0	/	/	/	/	/	/	/	/	/	/	/
8	RAJA RAJAN A	CSE	B - II	208	/	/	/	/	/	/	/	/	/	/	/	/	/	0	0	0	0	/	/	/	/	/	/	/
9	JEEVITHA R	CSE	B - II	208	/	/	/	/	/	/	/	/	/	/	/	/	/	/	/	/	/	/	/	/	/	/	/	/
10	SHILPA B	CSE	B - II	208	/	/	/	/	0	0	0	0	/	/	/	/	/	/	/	/	/	/	/	/	/	/	/	/
11	SOUNDHARYA A	CSE	B - II	208	/	/	/	/	/	/	/	/	0	0	0	0	/	/	/	/	/	/	/	/	/	/	/	/
12	INDIRA PRIYADHARSHINI P	CSE	B - II	208	0	0	0	0	/	/	/	/	/	/	/	/	/	/	/	/	/	/	/	0	0	0	0	0
13	PRAVEEN KUMAR M	CSE	B - III	102	/	/	/	/	/	/	/	/	/	/	/	/	/	/	/	/	/	/	/	/	/	/	/	/
14	YUVAPRIYANKA V	CSE	B - III	102	/	/	/	/	/	/	/	/	/	/	/	/	/	/	/	/	/	/	/	/	/	/	/	/
15	MANIKANDAN K	CSE	B - III	102	/	/	/	/	/	/	/	/	/	/	/	/	/	/	/	/	/	/	/	/	/	/	/	/
16	PUGAZHIVELAN P	CSE	B - III	102	/	/	/	/	0	0	0	0	/	/	/	/	/	/	/	/	/	/	/	/	/	/	/	/
17	AJITH KUMAR P	CSE	B - IV	209	/	/	/	/	/	/	/	/	/	0	0	0	0	/	/	/	/	/	/	0	0	0	0	0
18	MEGASURIYAN E	CSE	B - IV	209	/	/	/	/	/	/	/	/	/	/	/	/	/	/	/	/	/	/	/	/	/	/	/	/
19	DHRANI K	CSE	B - IV	209	0	0	0	0	/	/	/	/	/	/	/	/	/	/	/	/	/	/	/	/	/	/	/	/
20	HARINI R	CSE	B - IV	209	/	/	/	/	/	/	/	/	/	/	/	/	/	/	/	/	/	/	/	/	/	/	/	/
21	ILAKIYA S	CSE	B - IV	209	/	/	/	/	/	/	/	/	/	/	/	/	/	/	/	/	/	/	/	/	/	/	/	/
22	SELVAMALINI J	CSE	B - IV	209	/	/	/	/	/	/	/	/	/	/	/	/	/	/	/	/	/	/	/	/	/	/	/	/
23	SRUTHI S	CSE	B - V	109	0	0	0	0	/	/	/	/	/	/	/	/	/	/	/	/	/	/	0	0	0	0	0	0
24	DEVADHARSHINI SS	CSE	B - V	109	/	/	/	/	0	0	0	0	/	/	/	/	/	/	/	/	/	/	/	/	/	/	/	/
25	VENMATHI S	CSE	B - V	109	/	/	/	/	/	/	/	/	/	/	/	/	/	/	/	/	/	/	/	/	/	/	/	/
26	GOWRI S	CSE	B - V	109	/	/	/	/	/	/	/	/	/	/	/	/	/	/	/	/	/	/	/	/	/	/	/	/
27	INDHU R	CSE	B - V	109	/	/	/	/	/	/	/	/	/	/	/	/	/	/	/	/	/	/	/	/	/	/	/	/
28	NATHISH KUMAR A	CSE	B - V	109	0	0	0	0	/	/	/	/	/	/	/	/	/	/	/	/	/	/	/	0	0	0	0	0
29	ARUN R	CSE	B - V	109	/	/	/	/	/	/	/	/	/	/	/	/	/	/	/	/	/	/	/	/	/	/	/	/
30	ANISHAN	CSE	B - V	109	/	/	/	/	/	/	/	/	/	0	0	0	0	/	/	/	/	/	/	/	/	/	/	/
31	SUBHASREE S	CSE	B VI	211	/	/	/	/	0	0	0	0	/	/	/	/	/	/	/	/	/	/	/	/	/	/	/	/
32	VENKATESH M	CSE	B VI	211	/	/	/	/	/	/	/	/	/	/	/	/	/	/	/	/	/	/	/	0	0	0	0	0
33	MOHAMMEDSAMIR A	CSE	B VI	211	0	0	0	0	/	/	/	/	0	0	0	0	/	/	/	/	/	/	/	/	/	/	/	/
34	LAXMANCIBI S	CSE	B VI	211	/	/	/	/	/	/	/	/	/	/	/	/	/	/	/	/	/	/	/	/	/	/	/	/
35	JAYAVARSHINI G	CSE	B VI	211	/	/	/	/	/	/	/	/	/	/	/	/	/	0	0	0	0	/	/	/	/	/	/	/

PRINCIPAL,  
K. S. R. INSTITUTE FOR  
ENGINEERING AND TECHNOLOGY,  
K. S. R. KALYAN NAGAR,  
TIRUCHENGODE - 637 215,  
NAMAKKAL DI, TAMIL NADU.

No	Name	Branch	Batch No	Hall No	11.12.17				12.12.17				13.12.17				14.12.17				15.12.17				16.12.17								
					FN	FN	AN	AN	FN	FN	AN	AN	FN	FN	AN	AN	FN	FN	AN	AN	FN	FN	AN	AN	FN	FN	AN	AN	FN	FN	AN	AN	
36	PAVITHIRAN S	CSE	B VI	211	Q	Q	Q	Q	/	/	/	/	/	/	/	/	/	/	/	/	/	/	/	/	/	/	/	/	/	/	/	/	
37	VISVESWARAN B	CSE	B VI	211	/	/	/	/	/	/	/	/	Q	Q	Q	Q	/	/	/	/	/	/	/	/	/	/	/	/	/	/	/	/	
38	VIGNESH G	CSE	B VI	211	/	/	/	/	/	/	/	/	/	/	/	/	/	/	/	/	/	/	/	/	/	/	/	/	Q	Q	Q	Q	
39	PRIYANKA V	CSE	B VI	211	/	/	/	/	Q	Q	Q	Q	/	/	/	/	/	/	/	/	/	/	/	/	/	/	/	/	/	/	/	/	
40	BARATH K	CSE	B VI	211	/	/	/	/	/	/	/	/	/	/	/	/	/	/	/	/	/	/	/	/	/	/	/	/	Q	Q	Q	Q	
41	KAMALESH M	CSE	B-VII	112	/	/	/	/	/	/	/	/	/	/	/	/	/	/	/	/	/	/	/	/	/	/	/	/	/	/	/	/	
42	GOWTHAM KUMARAN P	CSE	B-VII	112	/	/	/	/	/	/	/	/	/	/	/	/	/	/	/	/	L	L	L	L	/	/	/	/	/	/	/	/	
43	AKILAN Y	CSE	B-VII	112	/	/	/	/	/	/	/	/	/	/	/	/	/	/	/	/	/	/	/	/	/	/	/	/	/	/	/	/	
44	PREMNATH R	CSE	B-VII	112	/	/	/	/	/	/	/	/	/	/	/	/	/	/	/	/	/	/	/	/	/	/	/	/	/	/	/	/	
45	DEEPAK SURIYA A	CSE	B-VII	112	/	/	/	/	Q	Q	Q	Q	L	L	L	L	/	/	/	/	/	/	/	/	/	/	/	/	/	/	/	/	
46	NIVETHITHA N	CSE	B-VII	112	<b>Discontinue</b>																												
47	PUJAA V	CSE	B-VII	112	<b>Discontinue</b>																												
<b>PRESENT</b>																																	
<b>ABSENT</b>																																	
<b>LEAVE</b>																																	
<b>NOT INTEREST</b>																																	

  
**PRINCIPAL,**  
**K. S. R. INSTITUTE FOR**  
**ENGINEERING AND TECHNOLOGY,**  
**K. S. R. KALVI NAGAR,**  
**TIRUCHENGODE - 637 215,**  
**NAMAKKAL Dt, TAMIL NADU.**

## Training and Placement Cell - IT

## 3-Day Training Schedule on Aptitude &amp; Basic Grammar and Soft Skills Attendance

BATCH : 2016 - 2020

Academic Year: 2017 - 2018

Year / Sem: II / IV

Staff Incharge:

S. No	Name	Branch	Batch No	Hall No	11.12.17				12.12.17				13.12.17				14.12.17				15.12.17				16.12.17				
					FN	FN	AN	AN	FN	FN	AN	AN	FN	FN	AN	AN	FN	FN	AN	AN	FN	FN	AN	AN	FN	FN	AN	AN	
1	JANANI M	IT	B-I	101	/	/	/	/	/	/	/	/	/	/	/	/	/	/	/	/	/	/	/	/	/	/	/	/	/
2	SARASWATHY K	IT	B-I	101	/	/	/	/	/	/	/	/	/	/	/	/	/	/	/	/	/	/	/	/	/	/	/	/	/
3	YUVAPRIYA R	IT	B-II	208	/	/	/	/	/	/	/	/	/	/	/	/	/	/	/	/	/	/	/	/	/	/	/	/	/
4	OVIYA A	IT	B-II	208	/	/	/	/	/	/	/	/	/	/	/	/	/	/	/	/	/	/	/	/	/	/	/	/	/
5	SAM MCKENZIE R	IT	B-II	208	/	/	/	/	/	/	/	/	/	/	/	/	/	/	/	/	/	/	/	/	/	/	/	/	/
6	PRIYADARSHNI G	IT	B-II	208	/	/	/	/	/	/	/	/	/	/	/	/	/	/	/	/	/	/	/	/	/	/	/	/	/
7	JANANI T	IT	B-III	102	/	/	/	/	/	/	/	/	/	/	/	/	/	/	/	/	/	/	/	/	/	/	/	/	/
8	HAKKEM M	IT	B-III	102	/	/	/	/	/	/	/	/	/	/	/	/	/	/	/	/	/	/	/	/	/	/	/	/	/
9	MOHANRAJ S	IT	B-III	102	/	/	/	/	/	/	/	/	/	/	/	/	/	/	/	/	/	/	/	/	/	/	/	/	/
10	SUMITHA J	IT	B-III	102	/	/	/	/	/	/	/	/	/	/	/	/	/	/	/	/	/	/	/	/	/	/	/	/	/
11	GOWRI D	IT	B-III	102	/	/	/	/	/	/	/	/	/	/	/	/	/	/	/	/	/	/	/	/	/	/	/	/	/
12	JANANI R	IT	B-IV	209	/	/	/	/	/	/	/	/	/	/	/	/	/	/	/	/	/	/	/	/	/	/	/	/	/
13	KARKULAZHI S	IT	B-IV	209	/	/	/	/	/	/	/	/	/	/	/	/	/	/	/	/	/	/	/	/	/	/	/	/	/
14	STEPHENRAJ J	IT	B-IV	209	/	/	/	/	/	/	/	/	/	/	/	/	/	/	/	/	/	/	/	/	/	/	/	/	/
15	SAKTHIRAVIKUMAR M	IT	B-IV	209	/	/	/	/	/	/	/	/	/	/	/	/	/	/	/	/	/	/	/	/	/	/	/	/	/
16	MANI BHARATHI G	IT	B-V	109	/	/	/	/	/	/	/	/	/	/	/	/	/	/	/	/	/	/	/	/	/	/	/	/	/
17	SUGITHA S	IT	B-V	109	/	/	/	/	/	/	/	/	/	/	/	/	/	/	/	/	/	/	/	/	/	/	/	/	/
18	YAKSHEETHA V	IT	B-V	109	/	/	/	/	/	/	/	/	/	/	/	/	/	/	/	/	/	/	/	/	/	/	/	/	/
19	TAMILARASAN G	IT	B-V	109	/	/	/	/	/	/	/	/	/	/	/	/	/	/	/	/	/	/	/	/	/	/	/	/	/
20	NESHAK KUMAR S	IT	B-V	109	/	/	/	/	/	/	/	/	/	/	/	/	/	/	/	/	/	/	/	/	/	/	/	/	/
21	STEEPHEN V	IT	B-V	109	/	/	/	/	/	/	/	/	/	/	/	/	/	/	/	/	/	/	/	/	/	/	/	/	/
22	INDHUMATHI S	IT	B-VI	211	/	/	/	/	/	/	/	/	/	/	/	/	/	/	/	/	/	/	/	/	/	/	/	/	/
	BOOPALAN G	IT	B-VI	211	/	/	/	/	/	/	/	/	/	/	/	/	/	/	/	/	/	/	/	/	/	/	/	/	/
24	KAUSALYA J	IT	B-VI	211	/	/	/	/	/	/	/	/	/	/	/	/	/	/	/	/	/	/	/	/	/	/	/	/	/
25	GOPI S	IT	B-VI	211	/	/	/	/	/	/	/	/	/	/	/	/	/	/	/	/	/	/	/	/	/	/	/	/	/
26	VIJI V	IT	B-VI	211	/	/	/	/	/	/	/	/	/	/	/	/	/	/	/	/	/	/	/	/	/	/	/	/	/
27	SATHAMHUSSAIN M S	IT	B-VI	211	/	/	/	/	/	/	/	/	/	/	/	/	/	/	/	/	/	/	/	/	/	/	/	/	/
28	MOUNIKA S	IT	B-VI	211	/	/	/	/	/	/	/	/	/	/	/	/	/	/	/	/	/	/	/	/	/	/	/	/	/
29	SUDARSAN S	IT	B-VI	211	/	/	/	/	/	/	/	/	/	/	/	/	/	/	/	/	/	/	/	/	/	/	/	/	/
30	SWETHA S	IT	B-VI	211	/	/	/	/	/	/	/	/	/	/	/	/	/	/	/	/	/	/	/	/	/	/	/	/	/
31	ARAVINDH K	IT	B-VI	211	/	/	/	/	/	/	/	/	/	/	/	/	/	/	/	/	/	/	/	/	/	/	/	/	/
32	KARTHIKA M	IT	B-VII	112	/	/	/	/	/	/	/	/	/	/	/	/	/	/	/	/	/	/	/	/	/	/	/	/	/
33	MOHANKUMAR M	IT	B-VII	112	/	/	/	/	/	/	/	/	/	/	/	/	/	/	/	/	/	/	/	/	/	/	/	/	/
34	KIRUBAKARAN R	IT	B-VII	112	/	/	/	/	/	/	/	/	/	/	/	/	/	/	/	/	/	/	/	/	/	/	/	/	/

PRINCIPAL,  
K. S. R. INSTITUTE FOR  
ENGINEERING AND TECHNOLOGY,  
K. S. R. KALVI NAGAR,  
TIRUCHENGODE - 637 215,  
NAMAKKAL DL, TAMIL NADU.

S. No	Name	Branch	Batch No	Hall No	11.12.17				12.12.17				13.12.17				14.12.17				15.12.17				16.12.17								
					FN	FN	AN	AN	FN	FN	AN	AN	FN	FN	AN	AN	FN	FN	AN	AN	FN	FN	AN	AN	FN	FN	AN	AN	FN	FN	AN	AN	
35	ARUN KUMAR A	IT	B- VII	112	/	/	/	/	/	/	/	/	/	/	/	/	/	/	/	/	/	/	/	/	/	/	/	/	/	/	/	/	
36	SATHAS R	IT	B- VII	112	/	/	/	/	a	a	a	a	/	/	/	/	a	a	a	a	/	/	/	/	/	/	/	/	/	/	/	/	
37	AHAMED FAISHAL H	IT	B- VII	112	/	/	/	/	/	/	/	/	/	/	/	/	/	/	/	/	/	/	/	/	/	/	/	/	/	/	/	/	
38	VINOTH M	IT	B- VII	112	/	/	/	/	/	/	/	/	/	/	/	/	/	/	/	/	/	/	/	/	/	/	/	/	/	/	/	/	
39	GOWTHAM D	IT	B- VII	112	/	/	/	/	/	/	/	/	/	/	/	/	a	a	a	a	/	/	/	/	/	/	/	/	/	/	/	/	
40	PRATHAP KUMAR E	IT	B- VII	112	/	/	/	/	/	/	/	/	/	/	/	/	/	/	/	/	/	/	/	/	/	/	/	/	/	/	/	/	
41	VIGNESH M	IT	B- VII	112	/	/	/	/	/	/	/	/	/	/	/	/	/	/	/	/	a	a	a	a	/	/	/	/	/	/	/	/	
42	IYYAPPAN J	IT	B- VII	112	/	/	/	/	a	a	a	a	/	/	/	/	/	/	/	/	/	/	/	/	/	/	/	/	/	/	/	/	
43	DEEPAN K	IT	B- VII	112	/	/	/	/	/	/	/	/	/	/	/	/	a	a	a	a	/	/	/	/	/	/	/	/	/	/	/	/	
44	AJITH KUMAR M	IT	B- VII	112	/	/	/	/	/	/	/	/	/	/	/	/	/	/	/	/	/	/	/	/	/	/	/	/	/	/	/	/	
45	BALAKRISHNA K	IT	B- VII	112	<b>Discontinue</b>																												
<b>PRESENT</b>																																	
<b>ABSENT</b>																																	
<b>LEAVE</b>																																	
<b>NOT INTEREST</b>																																	

  
**PRINCIPAL,**  
**K. S. R. INSTITUTE FOR**  
**ENGINEERING AND TECHNOLOGY,**  
**K. S. R. KALVI NAGAR,**  
**TIRUCHENGODE - 637 215,**  
**NAMAKKAL DISTRICT, TAMIL NADU.**

3-Day Training Schedule on Aptitude & Basic Grammar and Soft Skills Attendance

BATCH : 2016 - 2020

Academic Year: 2017 - 2018

Year / Sem: II / IV

Staff Incharge:

S. No	Name	Branch	Batch No	Hall No	11.12.17			12.12.17			13.12.17			14.12.17			15.12.17			16.12.17		
					FN	FN	AN	FN	FN	AN	FN	FN	AN	FN	FN	AN	FN	FN	AN	FN	FN	AN
1	SANTHOSH KUMAR V	MECH B	B-I	101	/	/	/	/	/	/	/	/	/	/	/	/	/	/	/	/	/	
2	VINOTHMANI M	MECH B	B-I	101	/	/	/	/	/	/	/	a	a	a	/	/	/	/	/	/	/	
3	RUTHRANNAN B	MECH B	B-I	101	/	/	/	/	/	/	/	/	/	/	/	/	/	/	/	/	/	
4	SHANMUGAMANIVEL D	MECH B	B-I	101	/	/	/	/	/	/	/	l	l	l	l	/	/	/	/	/	/	
5	SURENDHAR J	MECH B	B-I	101	/	/	/	/	/	/	/	/	/	/	/	/	/	/	/	/	/	
6	RAVICHANDRAN S	MECH B	B-II	208	l	l	l	l	/	/	/	/	/	/	/	/	/	/	/	a	a	
7	SANJAY KUMAR S (18.06.1999)	MECH B	B-II	208	/	/	/	/	/	/	/	a	a	a	/	/	/	/	/	/	/	
8	SATHISH G	MECH B	B-II	208	/	/	/	/	/	/	/	/	/	/	/	/	/	/	/	/	/	
9	VASANTHAKUMAR P	MECH B	B-II	208	/	/	/	l	l	l	l	/	/	/	/	/	/	/	/	/	/	
10	RANJITH KUMAR V	MECH B	B-II	208	/	/	/	/	/	/	/	/	/	/	/	/	a	a	a	/	/	
	PRABHAKARAN M	MECH B	B-II	208	/	/	/	/	/	l	l	l	l	/	/	/	/	/	/	/	/	
12	NAMBIRAJ J	MECH B	B-III	102	a	a	a	a	/	/	/	/	/	/	/	/	/	/	/	/	/	
13	SAKTHIVEL R	MECH B	B-III	102	/	/	/	/	/	/	/	/	/	l	l	l	l	/	/	/	/	
14	PARTHASARATHY R	MECH B	B-III	102	/	/	/	/	/	/	a	a	a	/	/	/	/	/	/	/	/	
15	RANJITHKUMAR R	MECH B	B-III	102	/	/	/	/	/	/	/	/	/	/	/	/	/	/	/	/	/	
16	PRAVEENKUMAR S	MECH B	B-III	102	/	/	/	/	/	/	/	/	/	/	/	/	/	/	a	a	a	
17	YOGESH T	MECH B	B-III	102	/	l	l	l	/	/	/	/	/	/	/	/	/	/	/	/	/	
18	THIRUMURUGAN V	MECH B	B-III	102	/	/	/	/	/	/	/	/	/	/	/	/	/	/	/	/	/	
19	PRAVEEN R (07.01.1999)	MECH B	B-III	102	/	/	/	/	/	/	/	/	l	l	l	l	/	/	/	/	/	
20	SAKTHI GNANASUNDARAM R H	MECH B	B-III	102	/	/	/	/	/	/	a	a	a	a	/	/	/	/	/	/	/	
21	THAMOTHARAN J	MECH B	B-III	102	l	l	l	l	/	/	/	/	/	/	/	/	/	/	/	/	/	
22	NAVINKUMAR M	MECH B	B-III	102	/	/	/	/	/	/	/	/	/	/	/	/	/	/	/	/	/	
23	PRAKASH S	MECH B	B-III	102	/	/	/	/	/	/	/	/	/	/	/	a	a	a	a	/	/	
24	VIVEK P	MECH B	B-IV	209	/	/	/	/	/	/	/	/	/	/	/	/	/	/	/	/	/	
25	PRASANTH R	MECH B	B-IV	209	/	/	/	l	l	l	l	/	/	/	/	/	/	/	/	/	/	
26	RAGAVENDHAR S	MECH B	B-IV	209	/	/	/	/	/	/	a	a	a	a	/	/	/	/	/	/	/	
27	PRABAKARAN S	MECH B	B-IV	209	/	/	/	/	/	/	/	/	/	/	/	/	/	/	l	l	l	
28	SANTHOSH KUMAR B	MECH B	B-IV	209	/	/	/	/	/	/	/	/	/	/	/	/	/	/	/	/	/	
29	RIYAS AHAMED S	MECH B	B-IV	209	a	a	a	a	/	/	/	/	/	/	/	/	/	/	/	/	/	
30	VISHNU A	MECH B	B-IV	209	/	/	/	/	/	/	/	/	l	l	l	l	/	/	/	/	/	
31	RAJKUMAR S	MECH B	B-IV	209	/	/	/	/	/	/	/	/	/	/	/	/	/	/	/	l	l	
32	SARAN K	MECH B	B-IV	209	/	/	/	/	/	/	/	/	/	/	/	/	/	/	/	/	/	
33	SABARISH R	MECH B	B-IV	209	/	/	/	/	/	/	a	a	a	a	/	/	/	/	/	/	/	
34	NANDHAGOBAL S	MECH B	B-IV	209	l	l	l	l	/	/	/	/	/	/	/	/	/	/	/	/	/	
35	TAMILMUGILAN N	MECH B	B-V	109	/	/	/	/	/	/	/	/	/	/	/	/	/	/	/	/	/	
36	UTHAYA KUMAR M	MECH B	B-V	109	/	/	/	/	/	/	/	/	/	/	/	/	/	/	/	/	/	

S.No	Name	Branch	Batch No	Hall No	11.12.17				12.12.17				13.12.17				14.12.17				15.12.17				16.12.17			
					FN	FN	AN	AN	FN	FN	AN	AN	FN	FN	AN	AN	FN	FN	AN	AN	FN	FN	AN	AN	FN	FN	AN	AN
37	RAHUL C	MECH B	B- V	109	/	/	/	/	/	/	/	/	/	/	/	/	/	/	/	/	/	/	/	/	/	/	/	/
38	VIGNESH V	MECH B	B- V	109	/	/	/	/	/	/	/	/	a	a	a	a	/	/	/	/	/	/	/	/	/	/	/	/
39	SARANRAJ S	MECH B	B- V	109	/	/	/	/	l	l	l	l	/	/	/	/	/	/	/	/	/	/	/	/	/	/	/	/
40	VIJAYARAGAVAM P	MECH B	B- V	109	/	/	/	/	/	/	/	/	/	/	/	/	/	/	/	/	/	/	/	/	l	l	l	l
41	VIJAY ANAND G	MECH B	B- V	109	/	/	/	/	/	/	/	/	/	/	/	/	/	/	/	/	/	/	/	/	/	/	/	/
42	SANJAY KUMAR S K	MECH B	B- VI	211	/	/	/	/	/	/	/	/	l	l	l	l	/	/	/	/	/	/	/	/	/	/	/	/
43	RANJITH R	MECH B	B- VI	211	/	/	/	/	/	/	/	/	/	/	/	/	/	/	/	/	l	l	l	l	/	/	/	/
44	PREMKUMAR K R	MECH B	B- VI	211	a	a	a	a	/	/	/	/	/	/	/	/	/	/	/	/	/	/	/	/	/	/	/	/
45	PRAVEEN R	MECH B	B- VI	211	/	/	/	/	/	/	/	/	/	/	/	/	/	/	/	/	/	/	/	/	/	/	/	/
46	SURYA R	MECH B	B- VI	211	/	/	/	/	/	/	/	/	/	/	/	/	/	/	/	/	/	/	/	/	/	/	/	/
47	SHAKTHI R M	MECH B	B- VI	211	/	/	/	/	/	/	/	/	a	a	a	a	/	/	/	/	/	/	/	/	/	/	/	/
48	VELMURUGAN T	MECH B	B- VI	211	/	/	/	/	/	/	/	/	/	/	/	/	/	/	/	/	/	/	/	/	l	l	l	l
49	VASANTH S	MECH B	B- VII	112	/	/	/	/	/	/	/	/	/	/	/	/	/	/	/	/	/	/	/	/	/	/	/	/
50	SOWNDHARA	MECH B	B- VII	112	l	l	l	l	/	/	/	/	/	/	/	/	/	/	/	/	/	/	/	/	/	/	/	/
51	VIGNESH B	MECH B	B- VII	112	/	/	/	/	/	/	/	/	/	/	/	/	/	/	/	/	/	/	/	/	a	a	a	a
52	YOGARAJ G	MECH B	B- VII	112	/	/	/	/	/	/	/	/	/	/	/	/	l	l	l	l	/	/	/	/	/	/	/	/
53	SANJEEVI K P	MECH B	B- VII	112	/	/	/	/	/	/	/	/	/	/	/	/	/	/	/	/	/	/	/	/	/	/	/	/
<b>PRESENT</b>																												
<b>ABSENT</b>																												
<b>LEAVE</b>																												
<b>NOT INTEREST</b>																												

  
 PRINCIPAL,  
 K. S. R. INSTITUTE FOR  
 ENGINEERING AND TECHNOLOGY,  
 K. S. R. KALVI NAGAR,  
 TIRUCHENGODE - 637 215,  
 NAMAKKAL Dt, TAMIL NADU.



## Training and Placement Cell - MECH - A

## 3-Day Training Schedule on Aptitude &amp; Basic Grammar and Soft Skills Attendance

BATCH : 2016 - 2020

Hall No: MIC -

Academic Year: 2017 - 2018

Year / Sem: II / IV

Staff Incharge:

S. No	Name	Branch	Batch No	Hall No	11.12.17			12.12.17			13.12.17			14.12.17			15.12.17			16.12.17		
					FN	FN	AN	FN	FN	AN	FN	FN	AN	FN	FN	AN	FN	FN	AN	FN	FN	AN
1	ANNAMALAI K	MECH A	B-I	101	/	/	/	/	/	/	/	/	/	/	/	/	/	/	/	/	/	
2	INBARASAN C	MECH A	B-I	101	a	a	a	/	/	/	/	/	/	/	/	/	/	/	/	/	/	
3	DEEPAK R	MECH A	B-I	101	/	/	/	/	/	/	/	/	/	/	/	/	/	/	/	/	/	
4	GUNASEKARAN R	MECH A	B-I	101	/	/	/	/	/	/	/	/	/	/	/	/	/	/	/	/	/	
5	DINESH KUMAR C	MECH A	B-I	101	a	a	a	/	/	/	/	/	/	/	/	/	/	/	/	/	/	
6	MADHANKUMAR L	MECH A	B-I	101	/	/	/	/	/	/	/	/	/	/	/	/	/	/	/	/	/	
7	GOKULRAJ P	MECH A	B-I	101	a	a	a	/	/	/	/	/	/	/	/	/	/	/	/	/	/	
8	JESTINRAJ K	MECH A	B-I	101	/	/	/	/	/	/	/	/	/	/	/	/	/	/	/	/	/	
9	LAKSHMI NARAYANAN R	MECH A	B-II	208	/	/	/	/	/	/	/	/	/	/	/	/	/	/	/	/	/	
10	MOHANA KRISHNAN D	MECH A	B-II	208	a	a	a	/	/	/	/	/	/	/	/	/	/	/	/	/	/	
11	JAYAMURUGAN K S	MECH A	B-II	208	/	/	/	/	/	/	/	/	/	/	/	/	/	/	/	/	/	
12	LOGESH S	MECH A	B-II	208	/	/	/	/	/	/	/	/	/	/	/	/	/	/	/	/	/	
13	ASWINKUMAR S	MECH A	B-II	208	/	/	/	a	a	a	/	/	/	/	/	/	/	/	/	/	/	
14	HARI SHANKAR P	MECH A	B-II	208	/	/	/	/	/	/	/	/	/	/	/	/	/	/	/	/	/	
15	DHEVENDRAN E	MECH A	B-II	208	a	a	a	/	/	/	/	/	/	/	/	/	/	/	/	/	/	
16	LOGESH N	MECH A	B-II	208	/	/	/	/	/	/	/	/	/	a	a	a	/	/	/	/	/	
17	JOSHUA Y	MECH A	B-II	208	/	/	/	/	/	/	/	/	/	/	/	/	/	/	/	/	/	
18	BALAJI M	MECH A	B-II	208	a	a	a	/	/	/	a	a	a	/	/	/	/	/	/	/	/	
19	KALEESWARAN D	MECH A	B-II	208	/	/	/	/	/	/	/	/	/	/	/	/	/	/	/	/	/	
20	HARIHARAN M	MECH A	B-II	208	/	/	/	/	/	/	/	/	/	/	/	/	/	/	/	/	/	
21	GOPINATH G	MECH A	B-II	208	a	a	a	/	/	/	/	/	/	/	/	/	/	/	/	/	/	
22	KEERTHIVASAN.S	MECH A	B-II	208	/	/	/	/	/	/	/	/	/	/	/	/	/	/	/	/	/	
23	KARTHIKEYAN P	MECH A	B-II	208	/	/	/	a	a	a	/	/	/	/	/	/	/	/	/	/	/	
24	GOVINDASAMY.A	MECH A	B-II	208	a	a	a	/	/	/	a	a	a	/	/	/	/	/	/	/	/	
25	KEVIN SEBASTIN R	MECH A	B-III	102	Discontinue																	
26	KAROLE INFANTO D	MECH A	B-III	102	/	/	/	/	/	/	/	/	/	/	/	/	/	/	/	/	/	
27	DHINAKARAN P	MECH A	B-III	102	/	/	/	/	/	/	/	/	/	/	/	/	/	/	/	/	/	
28	BHARATH V	MECH A	B-III	102	/	/	/	/	/	/	/	/	/	/	/	/	/	/	/	/	/	
29	JEEVA M	MECH A	B-III	102	a	a	a	/	/	/	a	a	a	/	/	/	/	/	/	/	/	
30	HARIHARAN S	MECH A	B-III	102	/	/	/	/	/	/	/	/	/	/	/	/	/	/	/	/	/	
31	CHANDRASEKAR K	MECH A	B-III	102	a	a	a	/	/	/	a	a	a	/	/	/	/	/	/	/	/	
32	JEEVANANDHAM N	MECH A	B-III	102	/	/	/	/	/	/	/	/	/	/	/	/	/	/	/	/	/	
33	PRASANTH S	MECH A	B-III	102	/	/	/	/	/	/	/	/	/	/	/	/	/	/	/	/	/	
34	KESAV GOUTHAM N B	MECH A	B-IV	209	a	a	a	/	/	/	/	/	/	/	/	/	/	/	/	/	/	
35	MANIKANDAN V	MECH A	B-IV	209	/	/	/	/	/	/	/	/	/	/	/	/	/	/	/	/	/	
36	ETHAYAKUMAR G	MECH A	B-IV	209	/	/	/	/	/	/	/	/	/	/	/	/	/	/	/	/	/	

No	Name	Branch	Batch No	Hall No	11.12.17				12.12.17				13.12.17				14.12.17				15.12.17				16.12.17							
					FN	FN	AN	AN	FN	FN	AN	AN	FN	FN	AN	AN	FN	FN	AN	AN	FN	FN	AN	AN	FN	FN	AN	AN	FN	FN	AN	AN
37	KARTHI S	MECH A	B-IV	209	/	/	/	/	/	/	/	/	/	/	/	/	/	/	/	/	/	/	/	/	/	/	/	/	/	/	/	/
38	KIRUBAKARAN M	MECH A	B-V	109	/	/	/	/	/	/	/	/	/	/	/	/	/	/	/	/	/	/	/	/	/	/	/	/	/	/	/	/
39	CHELLATHURAI T	MECH A	B-V	109	a	a	a	a	/	/	/	/	/	/	/	/	/	/	/	/	/	/	/	/	/	/	/	/	/	/	/	/
40	AAKASH S	MECH A	B-V	109	/	/	/	/	/	/	/	/	/	/	/	/	/	/	/	/	/	/	/	/	/	/	/	/	a	a	a	a
41	BOOPATHY K M	MECH A	B-V	109	/	/	/	/	/	/	/	/	/	/	/	/	/	/	/	/	/	/	/	/	/	/	/	/	/	/	/	/
42	KAVINKUMAR R	MECH A	B-V	109	a	a	a	a	/	/	/	/	/	/	/	/	/	/	/	/	/	/	/	/	/	/	/	/	/	/	/	/
43	MOHANRAJ B	MECH A	B-V	109	/	/	/	/	/	/	/	/	a	a	a	a	/	/	/	/	/	/	/	/	/	/	/	/	a	a	a	a
44	MAGESWARAN A	MECH A	B-V	109	/	/	/	/	/	/	/	/	/	/	/	/	/	/	/	/	/	/	/	/	/	/	/	/	/	/	/	/
45	KAVIN P	MECH A	B-V	109	a	a	a	a	/	/	/	/	a	a	a	a	/	/	/	/	a	a	a	a	/	/	/	/	/	/	/	/
46	JEEVA K	MECH A	B-VI	211	/	/	/	/	/	/	/	/	/	/	/	/	/	/	/	/	/	/	/	/	/	/	/	/	a	a	a	a
47	BOOPATHIRAJA E	MECH A	B-VI	211	/	/	/	/	/	/	/	/	/	/	/	/	/	/	/	/	/	/	/	/	/	/	/	/	/	/	/	/
48	GOWTHAM P	MECH A	B-VI	211	a	a	a	a	/	/	/	/	/	/	/	/	/	/	/	/	/	/	/	/	/	/	/	/	a	a	a	a
49	ARSHATH S	MECH A	B-VI	211	/	/	/	/	/	/	/	/	a	a	a	a	/	/	/	/	/	/	/	/	/	/	/	/	/	/	/	/
50	MOHAMMED NIHAL R	MECH A	B-VI	211	/	/	/	/	/	/	/	/	/	/	/	/	/	/	/	/	/	/	/	/	/	/	/	/	a	a	a	a
51	GOKUL R	MECH A	B-VII	112	/	/	/	/	/	/	/	/	/	/	/	/	/	/	/	/	/	/	/	/	/	/	/	/	/	/	/	/
52	MANOJ KUMAR K	MECH A	B-VII	112	/	/	/	/	/	/	/	/	a	a	a	a	/	/	/	/	/	/	/	/	/	/	/	/	/	/	/	/
53	DHAYANIDHI M	MECH A	B-VII	112	a	a	a	a	/	/	/	/	/	/	/	/	/	/	/	/	/	/	/	/	/	/	/	/	a	a	a	a
54	AJITH M	MECH A	B-VII	112	/	/	/	/	/	/	/	/	/	/	/	/	/	/	/	/	/	/	/	/	/	/	/	/	/	/	/	/
55	MOHAN ARJUN KUMARAVEL	MECH A	B-VII	112	/	/	/	/	/	/	/	/	/	/	/	/	/	/	/	/	/	/	/	/	/	/	/	/	/	/	/	/
56	BARATH V	MECH A	B-VII	112	/	/	/	/	/	/	/	/	/	/	/	/	/	/	/	/	/	/	/	/	/	/	/	/	a	a	a	a
PRESENT																																
ABSENT																																
LEAVE																																
NOT INTEREST																																

**PRINCIPAL,**  
**K. S. R. INSTITUTE FOR**  
**ENGINEERING AND TECHNOLOGY,**  
**K. S. R. KALVI NAGAR,**  
**TIRUCHENGODE - 637 215,**  
**NAMAKKAL Dt, TAMIL NADU.**

BATCH : 2016 - 2020

Academic Year: 2017 - 2018

Year / Sem: II / IV

Staff Incharge:

S. No	Name	Branch	Batch No	Hall No	11.12.17				12.12.17				13.12.17				14.12.17				15.12.17				16.12.17				
					FN	FN	AN	AN	FN	FN	AN	AN	FN	FN	AN	AN	FN	FN	AN	AN	FN	FN	AN	AN	FN	FN	AN	AN	
1	SARANYA.P	EEE	B-I	101	/	/	/	/	/	/	/	/	/	/	/	/	/	/	/	/	/	/	/	/	/	/	/		
2	MYTHILIN	EEE	B-I	101	/	/	/	/	/	/	/	/	/	/	a	a	a	a	/	/	/	/	/	/	/	/	/		
3	MADHUMITHA.J.S	EEE	B-I	101	/	/	/	/	/	/	/	/	/	/	/	/	/	/	/	/	/	/	/	/	/	/	/		
4	NITHIYASRI.R	EEE	B-I	101	/	/	/	/	/	/	/	/	/	/	/	/	/	/	a	a	a	a	/	/	/	/	/		
5	VIVEK.V	EEE	B-I	101	/	/	/	/	a	a	a	a	/	/	/	/	/	/	/	/	/	/	/	/	/	/	/		
6	NANDHINI.M	EEE	B-I	101	/	/	/	/	/	/	/	/	/	/	/	/	/	/	/	/	/	/	/	/	/	/	/		
7	SHANKAR NARAYAN.M	EEE	B-I	101	/	/	/	/	/	/	/	/	/	a	a	a	a	/	/	/	/	/	/	/	/	/	/		
8	EMAIYA.K	EEE	B-I	101	a	a	a	a	/	/	/	/	/	/	/	/	/	/	/	/	/	/	/	/	/	/	/		
9	MUGESH.M	EEE	B-II	208	/	/	/	/	/	/	/	/	/	/	/	/	/	/	a	a	a	a	/	/	/	/	/		
	PREMKUMAR.G	EEE	B-II	208	/	/	/	/	/	/	/	/	/	/	/	/	/	/	/	/	/	/	/	/	/	/	/		
11	KAMALI SOUNDARYA.B	EEE	B-II	208	/	/	/	/	/	/	/	/	/	/	/	/	/	/	/	/	/	/	/	/	/	/	/		
12	PREETHA.E	EEE	B-II	208	/	/	/	/	/	/	/	/	l	l	l	l	/	/	/	/	/	/	/	/	/	/	/		
13	LATHAS	EEE	B-II	208	/	/	/	/	/	/	/	/	/	/	/	/	/	/	/	/	/	/	/	/	/	/	/		
14	JANANI.T	EEE	B-II	208	l	l	l	l	/	/	/	/	/	/	/	/	/	/	/	/	/	/	/	/	/	/	/		
15	MONISHA.S	EEE	B-II	208	/	/	/	/	/	/	/	/	/	/	/	/	/	/	/	/	/	/	/	/	/	/	/		
16	BHARATHI KANNAN.M.R	EEE	B-II	208	/	/	/	/	/	/	/	/	/	/	a	a	a	a	/	/	/	/	/	/	/	/	/		
17	SUVETHA.T	EEE	B-II	208	/	/	/	/	/	/	/	/	/	/	/	/	/	/	a	a	a	a	/	/	/	/	/		
18	KARTHIK	EEE	B-II	208	/	/	/	/	/	/	/	/	a	a	a	a	/	/	/	/	/	/	/	/	/	/	/		
19	KARTHIKA DEVI.S	EEE	B-III	102	/	/	/	/	/	/	/	/	/	/	/	/	/	/	/	/	/	/	/	/	/	/	/		
20	SARAVANAN.V	EEE	B-III	102	/	/	/	/	/	/	/	/	/	/	/	/	/	/	/	/	/	/	/	/	/	/	/		
21	BOOPATHI.M	EEE	B-III	102	/	/	/	/	/	/	/	/	/	/	/	/	/	/	/	/	/	/	/	/	/	/	/		
22	PIREETHLA	EEE	B-III	102	/	/	/	/	a	a	a	a	/	/	/	/	/	/	/	/	/	/	/	/	/	/	/		
23	NANCY ASMITHA.P.A	EEE	B-III	102	/	/	/	/	/	/	/	/	/	/	/	/	/	/	/	/	/	/	/	/	/	a	a	a	a
24	MANOJKUMAR.V	EEE	B-III	102	/	/	/	/	/	/	/	/	/	/	/	/	/	/	/	/	/	/	/	/	/	/	/	/	
25	AJITHA.P	EEE	B-III	102	/	/	/	/	/	/	/	/	/	/	a	a	a	a	/	/	/	/	/	/	/	/	/	/	
26	LOGESHWARAN.V	EEE	B-III	102	/	/	/	/	/	/	/	/	/	/	/	/	/	/	/	/	/	/	/	/	/	/	/	/	
27	HARIHARAN.R	EEE	B-III	102	l	l	l	l	/	/	/	/	/	/	/	/	/	/	/	/	/	/	/	/	/	/	/	/	
28	MERLIN INFANTA	EEE	B-IV	209	/	/	/	/	/	/	/	/	/	/	/	/	/	/	/	/	/	/	/	/	/	/	/	/	
29	JEEVA.M	EEE	B-IV	209	/	/	/	/	/	/	/	/	/	/	/	/	/	/	/	/	/	/	/	/	a	a	a	a	
30	PRAKASH.S.P	EEE	B-IV	209	/	/	/	/	/	/	/	/	/	/	/	/	/	/	/	/	/	/	/	/	/	/	/	/	
31	BHARATH.S	EEE	B-IV	209	/	/	/	/	/	/	/	/	/	/	/	/	/	/	/	o	a	a	a	/	/	/	/	/	
32	DIVYADEVIV	EEE	B-IV	209	/	/	/	/	/	/	/	l	l	l	l	/	/	/	/	/	/	/	/	/	/	/	/	/	
33	SIBIN.S	EEE	B-IV	209	/	/	/	/	/	/	/	/	/	/	/	/	/	/	/	/	/	/	/	/	/	/	/	/	
34	SUJITHA.E	EEE	B-IV	209	/	/	/	l	l	l	l	/	/	/	/	/	/	/	/	/	/	/	/	/	/	/	/	/	

PRINCIPAL,  
 K. S. R. INSTITUTE FOR  
 ENGINEERING AND TECHNOLOGY,  
 K. S. R. KALVI NAGAR,  
 TIRUCHENGODE - 637 215,  
 NAMAKKAL Dt, TAMIL NADU.

No	Name	Branch	Batch No	Hall No	11.12.17				12.12.17				13.12.17				14.12.17				15.12.17				16.12.17					
					FN	FN	AN	AN	FN	FN	AN	AN	FN	FN	AN	AN	FN	FN	AN	AN	FN	FN	AN	AN	FN	FN	AN	AN	FN	FN
35	ANBALAGAN M	EEE	B- IV	209	/	/	/	/	/	/	/	/	/	/	/	/	/	/	/	/	/	/	/	/	/	/	/	/		
36	KAVIYA.M	EEE	B- V	109	/	/	/	/	/	/	/	/	/	/	/	/	/	/	/	/	/	/	/	/	/	/	/	/		
37	INIYADHARINI.R	EEE	B- V	109	/	/	/	/	/	/	/	/	/	/	/	/	/	/	/	/	/	/	/	/	/	/	/	/		
38	KANIMOZHI.V	EEE	B- V	109	/	/	/	/	a	a	a	a	/	/	/	/	/	/	/	/	/	/	/	/	/	/	/	/		
39	PRAVEEN.D	EEE	B- V	109	/	/	/	/	/	/	/	/	/	/	/	/	/	/	/	/	/	/	/	/	/	/	/	/		
40	PRAVIN.R	EEE	B- V	109	/	/	/	/	/	/	/	/	/	/	/	/	/	/	/	/	/	/	/	/	/	/	/	/		
41	GOKUL RAJ .M	EEE	B- V	109	/	/	/	/	/	/	/	/	/	/	/	/	/	/	/	/	/	/	/	/	/	/	/	/		
42	RATHNAKUMAR.V	EEE	B- V	109	/	/	/	/	/	/	/	/	/	/	/	/	/	/	/	/	/	/	/	/	/	/	/	/		
43	JEEVA.R	EEE	B- VI	211	/	/	/	/	/	/	/	/	/	/	/	/	a	a	a	a	/	/	/	/	/	/	/	/		
44	ARAVIND.R	EEE	B- VI	211	/	/	/	/	l	l	l	l	/	/	/	/	/	/	/	/	/	/	/	/	/	/	/	/		
45	MOHANRAJ.S	EEE	B- VI	211	/	/	/	/	/	/	/	/	/	/	/	/	/	/	/	/	/	/	/	/	/	/	/	/		
46	NAVANEETHAN.S	EEE	B- VI	211	/	/	/	/	/	/	/	/	/	/	/	/	/	/	/	/	/	/	/	/	/	l	l	l		
47	KAVINKUMAR.K	EEE	B- VI	211	/	/	/	/	/	/	/	/	/	/	/	/	/	/	/	/	/	/	/	/	/	/	/	/		
48	DINESHKUMAR. S	EEE	B- VI	211	a	a	a	a	/	/	/	/	/	/	/	/	/	/	/	/	/	/	/	/	/	/	/	/		
49	EDISON RAJA.R	EEE	B- VI	211	/	/	/	/	/	/	/	/	/	/	/	/	/	/	/	/	/	/	/	/	/	/	/	/		
50	AKILAN.G	EEE	B- VII	112	/	/	/	/	/	/	/	/	/	/	/	/	/	/	/	/	/	/	/	/	/	/	/	/		
51	GANESHBABU.V	EEE	B- VII	112	/	/	/	/	/	/	/	/	/	/	/	/	/	/	/	/	/	/	/	/	/	/	/	/		
52	MADHUBALAN.S	EEE	B- VII	112	/	/	/	/	/	/	/	/	/	/	/	/	/	/	/	/	/	/	/	/	/	/	/	/		
53	DHILIP KUMAR.S.K	EEE	B- VI	211	Discontinue																									
54	AJITH.K	EEE	B- VII	112	Discontinue																									
PRESENT																														
ABSENT																														
LEAVE																														
NOT INTEREST																														

  
**PRINCIPAL,**  
**K. S. R. INSTITUTE FOR**  
**ENGINEERING AND TECHNOLOGY,**  
**K. S. R. KALVI NAGAR,**  
**TIRUCHENGODE - 637 215,**  
**NAMAKKAL Dt, TAMIL NADU.**

## 3-Day Training Schedule on Aptitude &amp; Basic Grammar and Soft Skills Attendance

BATCH : 2016 - 2020

Academic Year: 2017 - 2018

Year / Sem: II / IV

Staff Incharge:

S. No	Name	Branch	Batch No	Hall No	11.12.17				12.12.17				13.12.17				14.12.17				15.12.17				16.12.17			
					FN	FN	AN	AN	FN	FN	AN	AN	FN	FN	AN	AN	FN	FN	AN	AN	FN	FN	AN	AN	FN	FN	AN	AN
1	NIVETHA S	ECE B	B-I	101	/	/	/	/	/	/	/	/	/	/	/	/	/	/	/	/	/	/	/	/	/	/	/	/
3	NAVA NANDHINI	ECE B	B-I	101	/	/	/	/	/	/	/	/	/	/	/	/	/	/	/	/	/	/	/	/	/	/	/	/
4	ROSHINI T	ECE B	B-I	101	/	/	/	/	/	/	/	/	/	/	/	/	/	/	/	/	/	/	/	/	/	/	/	/
5	TAMILARASI S	ECE B	B-I	101	/	/	/	/	/	/	/	/	/	/	/	/	/	/	/	/	/	/	/	/	/	/	/	/
6	PRIYANKA S S	ECE B	B-I	101	/	/	/	/	/	/	/	/	/	/	/	/	/	/	/	/	/	/	/	/	/	/	/	/
7	SELLAKRISHNARAJA S	ECE B	B-I	101	/	/	/	/	/	/	/	/	/	/	/	/	/	/	/	/	/	/	/	/	/	/	/	/
8	YOGESH S	ECE B	B-I	101	/	/	/	/	/	/	/	/	/	/	/	/	/	/	/	/	/	/	/	/	/	/	/	/
9	PRIYADHARSHNI P	ECE B	B-I	101	/	/	/	/	/	/	/	/	/	/	/	/	/	/	/	/	/	/	/	/	/	/	/	/
10	NARESHKUMAR S	ECE B	B-II	208	/	/	/	/	/	/	/	/	/	/	/	/	/	/	/	/	/	/	/	/	/	/	/	/
-	NIVETHA T	ECE B	B-II	208	/	/	/	/	/	/	/	/	/	/	/	/	/	/	/	/	/	/	/	/	/	/	/	/
12	SRIMATHI G	ECE B	B-II	208	/	/	/	/	/	/	/	/	/	/	/	/	/	/	/	/	/	/	/	/	/	/	/	/
13	NANDHAKUMAR P	ECE B	B-III	102	/	/	/	/	/	/	/	/	/	/	/	/	/	/	/	/	/	/	/	/	/	/	/	/
14	THAMARA KANNAN AS	ECE B	B-III	102	/	/	/	/	/	/	/	/	/	/	/	/	/	/	/	/	/	/	/	/	/	/	/	/
15	POORNIMA N	ECE B	B-III	102	/	/	/	/	/	/	/	/	/	/	/	/	/	/	/	/	/	/	/	/	/	/	/	/
16	SUMATHI R	ECE B	B-IV	209	/	/	/	/	/	/	/	/	/	/	/	/	/	/	/	/	/	/	/	/	/	/	/	/
17	PRIYADHARSHINI M	ECE B	B-IV	209	/	/	/	/	/	/	/	/	/	/	/	/	/	/	/	/	/	/	/	/	/	/	/	/
18	SATHYAMOORTHY K	ECE B	B-IV	209	/	/	/	/	/	/	/	/	/	/	/	/	/	/	/	/	/	/	/	/	/	/	/	/
19	NAVEEN K	ECE B	B-IV	209	/	/	/	/	/	/	/	/	/	/	/	/	/	/	/	/	/	/	/	/	/	/	/	/
20	RAMYA SRI E	ECE B	B-IV	209	/	/	/	/	/	/	/	/	/	/	/	/	/	/	/	/	/	/	/	/	/	/	/	/
21	SYED SALMAN N	ECE B	B-IV	209	/	/	/	/	/	/	/	/	/	/	/	/	/	/	/	/	/	/	/	/	/	/	/	/
22	SANTHIA G	ECE B	B-IV	209	/	/	/	/	/	/	/	/	/	/	/	/	/	/	/	/	/	/	/	/	/	/	/	/
23	NANDHAKUMARAN R	ECE B	B-IV	209	/	/	/	/	/	/	/	/	/	/	/	/	/	/	/	/	/	/	/	/	/	/	/	/
-	SANTHOSH KUMAR J	ECE B	B-IV	209	/	/	/	/	/	/	/	/	/	/	/	/	/	/	/	/	/	/	/	/	/	/	/	/
25	PRAVEENA M	ECE B	B-V	109	/	/	/	/	/	/	/	/	/	/	/	/	/	/	/	/	/	/	/	/	/	/	/	/
26	THARANYA P	ECE B	B-V	109	/	/	/	/	/	/	/	/	/	/	/	/	/	/	/	/	/	/	/	/	/	/	/	/
27	VIMAL KUMAR R	ECE B	B-V	109	/	/	/	/	/	/	/	/	/	/	/	/	/	/	/	/	/	/	/	/	/	/	/	/
28	THANGAVEL P	ECE B	B-V	109	/	/	/	/	/	/	/	/	/	/	/	/	/	/	/	/	/	/	/	/	/	/	/	/
29	PRIYADHARSHINI S	ECE B	B-V	109	/	/	/	/	/	/	/	/	/	/	/	/	/	/	/	/	/	/	/	/	/	/	/	/
30	SHARVESH RAM K R	ECE B	B-V	109	/	/	/	/	/	/	/	/	/	/	/	/	/	/	/	/	/	/	/	/	/	/	/	/
31	SHOWMIYA M	ECE B	B-V	109	/	/	/	/	/	/	/	/	/	/	/	/	/	/	/	/	/	/	/	/	/	/	/	/
32	SAKTHI PRIYA S	ECE B	B-V	109	/	/	/	/	/	/	/	/	/	/	/	/	/	/	/	/	/	/	/	/	/	/	/	/
33	PRIYANKA C	ECE B	B-VI	211	/	/	/	/	/	/	/	/	/	/	/	/	/	/	/	/	/	/	/	/	/	/	/	/
34	THANGARAJ J	ECE B	B-VI	211	/	/	/	/	/	/	/	/	/	/	/	/	/	/	/	/	/	/	/	/	/	/	/	/
35	NANDHAKUMAR M	ECE B	B-VI	211	/	/	/	/	/	/	/	/	/	/	/	/	/	/	/	/	/	/	/	/	/	/	/	/

PRINCIPAL,  
K. S. R. INSTITUTE FOR  
ENGINEERING AND TECHNOLOGY,  
K. S. R. KALM NAGAR,  
TIRUCHENGODE - 637 215,  
NAMAKKAL DI, TAMIL NADU.

S.No	Name	Branch	Batch No	Hall No	11.12.17				12.12.17				13.12.17				14.12.17				15.12.17				16.12.17							
					FN	FN	AN	AN	FN	FN	AN	AN	FN	FN	AN	AN	FN	FN	AN	AN	FN	FN	AN	AN	FN	FN	AN	AN	FN	FN	AN	AN
36	SHYAM SUNDAR R	ECE B	B- VI	211	/	/	/	/	a	a	a	a	/	/	/	/	/	/	/	/	/	/	/	/	/	/	/	/	/	/	/	/
37	VIGNESH R	ECE B	B- VII	112	a	a	a	a	/	/	/	/	/	/	/	/	/	/	/	/	/	/	/	/	a	a	a	a	/	/	/	/
38	SUBASH V	ECE B	B- VII	112	/	/	/	/	a	a	a	a	/	/	/	/	/	/	/	/	/	/	/	/	/	/	/	/	/	/	/	/
39	SURIYA E	ECE B	B- VII	112	/	/	/	/	/	/	/	/	a	a	a	a	l	l	l	l	/	/	/	/	/	/	/	/	/	/	/	/
40	SUBASHINI R	ECE B	B- VII	112	a	a	a	a	/	/	/	/	/	/	/	/	/	/	/	/	/	/	/	/	/	/	/	/	a	a	a	a
41	MUGILAN M	ECE B	B- VII	112	/	/	/	/	/	/	/	/	a	a	a	a	/	/	/	/	/	/	/	/	/	/	/	/	/	/	/	/
42	SURYA R	ECE B	B- VII	112	a	a	a	a	/	/	/	/	/	/	/	/	/	/	/	/	a	a	a	a	/	/	/	/	/	/	/	/
43	RANJITH V	ECE B	B- VII	112	/	/	/	/	/	/	/	/	a	a	a	a	/	/	/	/	/	/	/	/	/	/	/	/	/	/	/	/
44	VIGNESH P	ECE B	B- VII	112	/	/	/	/	a	a	a	a	/	/	/	/	l	l	l	l	/	/	/	/	/	/	/	/	/	/	/	/
<b>PRESENT</b>																																
<b>ABSENT</b>																																
<b>LEAVE</b>																																
<b>NOT INTEREST</b>																																

  
 PRINCIPAL,  
 K. S. R. INSTITUTE FOR  
 ENGINEERING AND TECHNOLOGY,  
 K. S. R. KALVI NAGAR,  
 TIRUCHENGODE - 637 215,  
 NAMAKKAL DI, TAMIL NADU.

S. No	Name	Branch	Batch No	Hall No	11.12.17				12.12.17				13.12.17				14.12.17				15.12.17				16.12.17			
					FN	FN	AN	AN	FN	FN	AN	AN	FN	FN	AN	AN	FN	FN	AN	AN	FN	FN	AN	AN	FN	FN	AN	AN
1	BALAJI R	ECE A	B-I	101	0	0	0	0	/	/	/	/	/	/	/	/	/	/	/	/	/	/	/	/	/	/	/	/
2	MARIMUTHU M	ECE A	B-I	101	/	/	/	/	/	/	/	/	/	/	/	/	/	/	/	/	/	/	/	/	/	/	/	/
3	KOKILA K	ECE A	B-I	101	/	/	/	/	0	0	0	0	/	/	/	/	/	/	/	/	/	/	/	/	/	/	/	/
4	ABDULKADHAR S	ECE A	B-I	101	0	0	0	0	/	/	/	/	/	/	/	/	/	/	/	/	/	/	/	/	/	/	/	/
5	JAYASHRI M	ECE A	B-I	101	/	/	/	/	/	/	/	/	/	/	/	/	/	/	/	/	/	/	/	/	0	0	0	0
6	BHAVYASHREE S	ECE A	B-I	101	/	/	/	/	/	/	/	/	/	/	/	/	/	/	/	/	/	/	/	/	/	/	/	/
7	ILAKIYA S	ECE A	B-I	101	/	/	/	/	/	/	/	/	/	/	/	/	/	/	/	/	0	0	0	0	/	/	/	/
8	ISWARYA P	ECE A	B-I	101	/	/	/	/	/	/	/	/	/	/	/	/	/	/	/	/	/	/	/	/	/	/	/	/
9	DURAIRAJ S	ECE A	B-I	101	/	/	/	/	/	/	/	/	0	0	0	0	/	/	/	/	/	/	/	/	/	/	/	/
10	DIVYA T	ECE A	B-I	101	/	/	/	/	/	/	/	/	/	/	/	/	/	/	/	/	/	/	/	/	/	/	/	/
11	AKSHAYA N M	ECE A	B-I	101	0	0	0	0	0	0	0	0	/	/	/	/	/	/	/	/	/	/	/	/	0	0	0	0
12	INDIRAKUMAR M	ECE A	B-I	101	/	/	/	/	/	/	/	/	/	/	/	/	/	/	/	/	/	/	/	/	/	/	/	/
13	LOGESH KUMAR K	ECE A	B-I	101	/	/	/	/	/	/	/	/	/	/	/	/	/	/	/	/	/	/	/	/	/	/	/	/
14	NATHIYA.V	ECE B	B-I	101	/	/	/	/	0	0	0	0	/	/	/	/	/	/	/	/	/	/	/	/	/	/	/	/
15	MONIKA R	ECE A	B-II	208	0	0	0	0	/	/	/	/	/	/	/	/	/	/	/	/	/	/	/	/	/	/	/	/
16	DANATHARSHINI G	ECE A	B-II	208	/	/	/	/	/	/	/	/	/	/	/	/	/	/	/	/	/	/	/	/	/	/	/	/
17	ANANTHA KRISHNAN P	ECE A	B-II	208	/	/	/	/	/	/	/	/	/	/	/	/	/	/	/	/	/	/	/	/	/	/	/	/
18	BRAHADEESHWARAN M	ECE A	B-III	102	/	/	/	/	/	/	/	/	/	/	/	/	/	/	/	/	/	/	/	/	/	/	/	/
19	BRINDHA M	ECE A	B-III	102	/	/	/	/	/	/	/	/	/	/	/	/	/	/	/	/	/	/	/	/	/	/	/	/
20	DHARANI V	ECE A	B-III	102	/	/	/	/	/	/	/	/	/	/	/	/	/	/	/	/	/	/	/	/	/	/	/	/
21	ASHWIN S	ECE A	B-III	102	/	/	/	/	/	/	/	/	/	/	/	/	/	/	/	/	/	/	/	/	0	0	0	0
22	MALATHI A.S	ECE A	B-III	102	/	/	/	/	/	/	/	/	/	/	/	/	/	/	/	/	/	/	/	/	/	/	/	/
23	MEKALAI K	ECE A	B-III	102	/	/	/	/	/	/	/	/	/	/	/	/	/	/	/	/	/	/	/	/	/	/	/	/
24	ANANTH N	ECE A	B-III	102	/	/	/	/	0	0	0	0	/	/	/	/	/	/	/	/	/	/	/	/	/	/	/	/
25	KANIMOZHI R	ECE A	B-III	102	/	/	/	/	/	/	/	/	/	/	/	/	/	/	/	/	/	/	/	/	/	/	/	/
26	KARTHIKEYAN V	ECE A	B-IV	209	/	/	/	/	/	/	/	/	/	/	/	/	/	/	/	/	/	/	/	/	/	/	/	/
27	BHAVYA D	ECE A	B-IV	209	/	/	/	/	/	/	/	/	/	/	/	/	/	/	/	/	/	/	/	/	/	/	/	/
28	DHIVYA T	ECE A	B-IV	209	0	0	0	0	/	/	/	/	/	/	/	/	/	/	/	/	/	/	/	/	/	/	/	/
29	MEENA A	ECE A	B-IV	209	/	/	/	/	/	/	/	/	/	/	/	/	/	/	/	/	/	/	/	/	0	0	0	0
30	BHUVANESHWARI P	ECE A	B-IV	209	/	/	/	/	/	/	/	/	/	/	/	/	/	/	/	/	/	/	/	/	/	/	/	/
31	GOWTHAM M	ECE A	B-IV	209	/	/	/	/	/	/	/	/	/	/	/	/	/	/	/	/	/	/	/	/	/	/	/	/
32	ADHITHYA KUMAR M	ECE A	B-V	109	/	/	/	/	0	0	0	0	/	/	/	/	/	/	/	/	/	/	/	/	/	/	/	/
33	ARULIEESWARAN R	ECE A	B-V	109	/	/	/	/	/	/	/	/	/	/	/	/	/	/	/	/	/	/	/	/	/	/	/	/
34	GOKULA KRISHNAN A	ECE A	B-V	109	0	0	0	0	/	/	/	/	/	/	/	/	/	/	/	/	/	/	/	/	/	/	/	/

PRINCIPAL,  
K. S. R. INSTITUTE FOR  
ENGINEERING AND TECHNOLOGY,  
K. S. R. KALVI NAGAR,  
TIRUCHENGODE - 637 215,  
NAMAKKAL DISTRICT, TAMIL NADU.

. No	Name	Branch	Batch No	Hall No	11.12.17				12.12.17				13.12.17				14.12.17				15.12.17				16.12.17							
					FN	FN	AN	AN	FN	FN	AN	AN	FN	FN	AN	AN	FN	FN	AN	AN	FN	FN	AN	AN	FN	FN	AN	AN	FN	FN	AN	AN
35	ELANGO VAN V	ECE A	B- V	109	/	/	/	/	/	/	/	/	/	/	/	/	/	/	/	/	/	/	/	/	/	/	/	/	/	/	/	/
36	KARTHIKEYAN S	ECE A	B- VI	211	L	L	L	L	/	/	/	/	/	/	/	/	/	/	/	/	/	/	/	/	/	/	/	/	/	/	/	/
37	LAKSHMANAN R	ECE A	B- VI	211	/	/	/	/	/	/	/	/	/	/	/	/	/	/	/	/	/	/	/	/	/	/	/	/	/	/	/	/
38	DINESH KRISHNA S	ECE A	B- VI	211	/	/	/	/	L	L	L	L	/	/	/	/	/	/	/	/	/	/	/	/	/	/	/	/	/	/	/	/
39	ABISHCK T	ECE A	B- VI	211	/	/	/	/	/	/	/	/	/	/	/	/	/	/	/	/	/	/	/	/	/	/	/	/	/	/	/	/
40	MAHESWARAN J	ECE A	B- VII	112	/	/	/	/	/	/	/	/	/	/	/	/	/	/	/	/	/	/	/	/	/	/	/	/	/	/	/	/
41	KAJAPATHY V	ECE A	B- VII	112	/	/	/	/	L	L	L	L	/	/	/	/	/	/	/	/	/	/	/	/	/	/	/	/	/	/	/	/
42	HARIHARAN C	ECE A	B- VII	112	Discontinue																											
43	AJEETH KUMMAR M	ECE A	B- VII	112																												
<b>PRESENT</b>																																
<b>ABSENT</b>																																
<b>LEAVE</b>																																
<b>NOT INTEREST</b>																																

  
 PRINCIPAL,  
 K. S. R. INSTITUTE FOR  
 ENGINEERING AND TECHNOLOGY,  
 K. S. R. KALVI NAGAR,  
 TIRUCHENGODE - 637 215,  
 NAMAKKAL Dt, TAMIL NADU.



Fore Noon session

S.NO	Branch	Strength	Present	Absent	Leave
1	CSE	45	37	8	0
2	ECE - A	41	34	6	1
3	ECE - B	44	35	8	1
4	EEE	52	48	2	2
5	IT	44	40	2	2
6	MECH - A	55	38	16	1
7	MECH - B	53	46	3	4
<b>Total</b>		<b>334</b>	<b>278</b>	<b>45</b>	<b>11</b>

After Noon Session

S.NO	BRANCH	Strength	PRESENT	ABSENT	Leave
1	CSE	45	37	8	0
2	ECE - A	41	34	6	1
3	ECE - B	44	35	8	1
4	EEE	52	48	2	2
5	IT	44	40	2	2
6	MECH - A	55	38	16	1
7	MECH - B	53	45	3	5
<b>Total</b>		<b>334</b>	<b>277</b>	<b>45</b>	<b>12</b>

*[Signature]*  
T&P OFFICER

*[Signature]*  
PRINCIPAL,  
K. S. R. INSTITUTE FOR  
ENGINEERING AND TECHNOLOGY,  
K. S. R. KALVI NAGAR,  
TIRUCHENGODE - 637 215,  
NAMACHAL DI, TAMIL NADU.

*[Signature]*  
PRINCIPAL

Fore Noon session

S.NO	Branch	Strength	Present	Absent	Leave
1	CSE	45	37	7	1
2	ECE - A	41	34	5	2
3	ECE - B	44	34	9	1
4	EEE	52	47	3	2
5	IT	44	40	4	0
6	MECH - A	55	50	2	3
7	MECH - B	53	50	0	3
<b>Total</b>		<b>334</b>	<b>292</b>	<b>30</b>	<b>12</b>

After Noon Session

S.NO	BRANCH	Strength	PRESENT	ABSENT	Leave
1	CSE	45	37	7	1
2	ECE - A	41	34	5	2
3	ECE - B	44	34	9	1
4	EEE	52	47	3	2
5	IT	44	40	4	0
6	MECH - A	55	50	2	3
7	MECH - B	53	50	0	3
<b>Total</b>		<b>334</b>	<b>292</b>	<b>30</b>	<b>12</b>

*[Handwritten Signature]*  
T & P OFFICER  
12/12/17

*[Handwritten Signature]*  
PRINCIPAL,  
K. S. R. INSTITUTE FOR  
ENGINEERING AND TECHNOLOGY,  
K. S. R. KALVI NAGAR,  
TIRUCHENGODE - 637 215,  
NAMAKKAL DI, TAMIL NADU.

*[Handwritten Signature]*  
PRINCIPAL

TRAINING & PLACEMENT CELL - Internal Training Programme



BATCH: 2016 - 2020

ACADEMIC YEAR: 2017 - 2018 (Even)

DATE: 13.12.2017

Fore Noon session

S.NO	Branch	Strength	Present	Absent	Leave
1	CSE	45	40	4	1
2	ECE - A	43	42	1	0
3	ECE - B	44	32	11	1
4	EEE	52	48	2	2
5	IT	44	39	3	2
6	MECH - A	55	45	9	1
7	MECH - B	53	42	8	3
<b>Total</b>		<b>336</b>	<b>288</b>	<b>38</b>	<b>10</b>

After Noon Session

S.NO	BRANCH	Strength	PRESENT	ABSENT	Leave
1	CSE	45	40	4	1
2	ECE - A	43	42	1	0
3	ECE - B	44	32	11	1
4	EEE	52	48	2	2
5	IT	44	37	4	3
6	MECH - A	55	45	9	1
7	MECH - B	53	42	8	3
<b>Total</b>		<b>336</b>	<b>286</b>	<b>39</b>	<b>11</b>

*[Signature]*  
T & P OFFICER  
13/12

*[Signature]*  
PRINCIPAL,  
K. S. R. INSTITUTE FOR  
ENGINEERING AND TECHNOLOGY,  
K. S. R. KALVIHAGAR,  
TIRUCHENGODE - 637 215,  
NAMAKKAL Dt, TAMIL NADU.

*[Signature]*  
PRINCIPAL

Fore Noon session

S.NO	Branch	Strength	Present	Absent	Leave
1	CSE	45	41	3	1
2	ECE - A	43	41	0	2
3	ECE - B	42	36	3	3
4	EEE	52	48	4	0
5	IT	44	33	8	3
6	MECH - A	56	50	1	5
7	MECH - B	53	49	0	4
<b>Total</b>		<b>335</b>	<b>298</b>	<b>19</b>	<b>18</b>

After Noon Session

S.NO	Branch	Strength	Present	Absent	Leave
1	CSE	45	41	3	1
2	ECE - A	43	41	0	2
3	ECE - B	44	36	3	3
4	EEE	52	48	4	0
5	IT	44	33	8	3
6	MECH - A	55	50	1	5
7	MECH - B	53	49	0	4
<b>Total</b>		<b>336</b>	<b>298</b>	<b>19</b>	<b>18</b>

*K. S. R. Kalvi*  
T & P OFFICER

*K. S. R. Kalvi*  
PRINCIPAL,  
K. S. R. INSTITUTE FOR  
ENGINEERING AND TECHNOLOGY,  
K. S. R. KALVI NAGAR,  
TIRUCHENGODE - 637 215,  
NAMAIGAL Dt, TAMIL NADU.

*K. S. R. Kalvi*  
PRINCIPAL

BATCH: 2016 - 2020

ACADEMIC YEAR: 2017 - 2018 (Even)

DATE: 15.12.2017

## Fore Noon session

S.NO	Branch	Strength	Present	Absent	Leave
1	CSE	45	37	3	5
2	ECE - A	43	41	1	1
3	ECE - B	42	32	9	1
4	EEE	52	47	4	1
5	IT	44	36	7	1
6	MECH - A	55	49	1	5
7	MECH - B	53	50	2	1
<b>Total</b>		<b>334</b>	<b>292</b>	<b>27</b>	<b>15</b>

## After Noon Session

S.NO	Branch	Strength	Present	Absent	Leave
1	CSE	45	37	3	5
2	ECE - A	43	40	1	2
3	ECE - B	42	32	9	1
4	EEE	52	47	4	1
5	IT	44	36	7	1
6	MECH - A	55	46	3	6
7	MECH - B	53	50	2	1
<b>Total</b>		<b>334</b>	<b>288</b>	<b>29</b>	<b>17</b>

  
 T & P OFFICER  
 15/12

  
 PRINCIPAL,  
 K. S. R. INSTITUTE FOR  
 ENGINEERING AND TECHNOLOGY,  
 K. S. R. KALVI NADAR,  
 TIRUCHENGODE - 637 215,  
 NAMAKKAL DC, TAMIL NADU.

  
 PRINCIPAL

Fore Noon session

S.NO	Branch	Strength	Present	Absent	Leave
1	CSE	45	37	8	0
2	ECE - A	41	34	6	1
3	ECE - B	44	35	8	1
4	EEE	52	48	2	2
5	IT	44	40	2	2
6	MECH - A	55	38	16	1
7	MECH - B	53	46	3	4
<b>Total</b>		<b>334</b>	<b>278</b>	<b>45</b>	<b>11</b>

After Noon Session

S.NO	Branch	Strength	Present	Absent	Leave
1	CSE	45	37	8	0
2	ECE - A	43	34	6	1
3	ECE - B	42	35	8	1
4	EEE	52	48	2	2
5	IT	44	40	2	2
6	MECH - A	55	38	16	1
7	MECH - B	53	45	3	5
<b>Total</b>		<b>334</b>	<b>277</b>	<b>45</b>	<b>12</b>

*F. K. Kalyan*  
T & P OFFICER

*[Signature]*  
PRINCIPAL,  
K. S. R. INSTITUTE FOR  
ENGINEERING AND TECHNOLOGY,  
K. S. R. KALVI NAGAR,  
TIRUCHENGODE - 637 215,  
NAMAKKAL Dt, TAMIL NADU.

*[Signature]*  
PRINCIPAL

TRAINING PROGRAMME FEEDBACK FORM



Name of the Student: P. Jhangavel

Branch: ECE

Year / Sem: II / IV

4. Name of the Training :

5. Name of the Trainer : Mohan

6. Students rating of Trainers :

S. No.	Date	Subject	Rating (√)			
			Excellent	Very good	Good	Average
1	11/12/17	English		✓		

(PN) ICE training, vocabulary

4. Two positive points about the programme:

5. Suggestions for improvement:

Date: 11/12/17

P. Jhangavel  
Signature

TRAINING PROGRAMME FEEDBACK FORM



Name of the Student: K. Saraswathy

Branch: B.Tech I I

Year / Sem: II - IV

4. Name of the Training : Error spotting, reading comprehension

5. Name of the Trainer : Mather

6. Students rating of Trainers : 8

S. No.	Date	Subject	Rating (√)			
			Excellent	Very good	Good	Average
1	11.12.17	English		✓		

4. Two positive points about the programme:

It is very useful for knowing vocabulary  
It improves our creativity

5. Suggestions for improvement:

It is little boring because it takes continuous class

Date: 11.12.17

PRINCIPAL  
K. S. R. INSTITUTE FOR ENGINEERING AND TECHNOLOGY,  
K. S. R. KALVIYAR,  
TIRUCHENGODE - 637 215,  
NAMAKKAL DISTRICT, TAMIL NADU.  
K. S. R. Kalviyar  
Signature

K S R INSTITUTE FOR ENGINEERING AND TECHNOLOGY  
TIRUCHENGODE - 637 215

TRAINING PROGRAMME FEEDBACK FORM



Name of the Student: Karthika Devi . S

Branch: EEE - II

Year / Sem: II - IV

1. Name of the Training : Placement Training

2. Name of the Trainer : Madhan.S

3. Students rating of Trainers :

S. No.	Date	Subject	Rating (✓)			
			Excellent	Very good	Good	Average
1	11.12.17	soft skills		✓		

4. Two positive points about the programme: 1) It was interesting  
2) It was helpful for our knowledge.

5. Suggestions for improvement: -

Date: 11.12.17

  
PRINCIPAL,  
K. S. R. INSTITUTE FOR  
ENGINEERING AND TECHNOLOGY,  
K. S. R. KALVI ROAD,  
TIRUCHENGODE - 637 215,  
NAMAKKAL DISTRICT, TAMIL NADU.

  
Signature





Name of the Student: R. Sumathi

Branch: IV

Year / Sem: II - IV

1. Name of the Training : Apptitude

2. Name of the Trainer : Sivakumal

3. Students rating of Trainers :

S. No.	Date	Subject	Rating (✓)			
			Excellent	Very good	Good	Average
1	11.12.17	Calendary and clocks		✓		

20

4. Two positive points about the programme: Projector and board teaching  
good approach.

5. Suggestions for improvement: Want some entreevel

Date: 11.12.17.

Signature



Name of the Student: R. Sumathi

Branch: IV

Year / Sem: II - IV

4. Name of the Training : Apptitude

5. Name of the Trainer : kumaranel

6. Students rating of Trainers :

S. No.	Date	Subject	Rating (✓)			
			Excellent	Very good	Good	Average
1	11.12.17	Distutions		✓		

10

4. Two positive points about the programme: good teaching  
Using Projector

5. Suggestions for improvement: want slow speed

Date: 11.12.17.

Signature  
PRINCIPAL,  
K. S. R. INSTITUTE FOR  
ENGINEERING AND TECHNOLOGY,  
K. S. R. KALM NAGAR,  
TIRUCHENGODE - 637 215,  
NAMAKKAL Dt, TAMIL NADU.

**K S R INSTITUTE FOR ENGINEERING AND TECHNOLOGY  
TIRUCHENGODE - 637 215**

**TRAINING PROGRAMME FEEDBACK FORM**



Name of the Student: S. Bharath Branch: EEE

Year / Sem: II / III

1. Name of the Training : ~~SIVAKUMAR~~ CLOCKS AND CALENDARS

2. Name of the Trainer : SIVAKUMAR

3. Students rating of Trainers :

S. No.	Date	Subject	Rating (√)			
			Excellent	Very good	Good	Average
1	11.12.17	APTITUDE	✓			

17

4. Two positive points about the programme:

Easy to understand  
Knows about the use of clocks and calendars

5. Suggestions for improvement:

-

Date: 11.12.17

*S. Bharath*  
Signature

**K S R INSTITUTE FOR ENGINEERING AND TECHNOLOGY  
TIRUCHENGODE - 637 215**

**TRAINING PROGRAMME FEEDBACK FORM**



Name of the Student: S. Bharath Branch: EEE

Year / Sem: II / III

4. Name of the Training : DIRECTIONS

5. Name of the Trainer : KUMARAVEL

6. Students rating of Trainers :

S. No.	Date	Subject	Rating (√)			
			Excellent	Very good	Good	Average
1	11.12.17	APTITUDE	✓			

12

4. Two positive points about the programme:

Helps to solve direction problems.  
Easy to understand.

5. Suggestions for improvement:

-

Date: 11.12.17

PRINCIPAL  
K. S. R. INSTITUTE FOR  
ENGINEERING AND TECHNOLOGY  
K. S. R. KALVI  
TIRUCHENGODE - 637 215,  
NAMAKKAL DISTRICT, TAMIL NADU.  
*S. Bharath*  
Signature

**K S R INSTITUTE FOR ENGINEERING AND TECHNOLOGY  
TIRUCHENGODE - 637 215**

**TRAINING PROGRAMME FEEDBACK FORM**



Name of the Student: P. Gowithama Kumar

Branch: CSE

Year / Sem: II/IV

1. Name of the Training : ANALOGY

2. Name of the Trainer : Ganaka Selvam

3. Students rating of Trainers :

S. No.	Date	Subject	Rating (√)			
			Excellent	Very good	Good	Average
1	11/12/17	Analogy	✓			

4. Two positive points about the programme:

\* It is interesting

\* do not boring

5. Suggestions for improvement:

\* ~~please~~ nothing

Date: 11/12/17

P. Gowithama Kumar  
Signature

**K S R INSTITUTE FOR ENGINEERING AND TECHNOLOGY  
TIRUCHENGODE - 637 215**

**TRAINING PROGRAMME FEEDBACK FORM**



Name of the Student: M. Vinath

Branch: IT

Year / Sem:

4. Name of the Training : SPEAKING

5. Name of the Trainer : Viji

6. Students rating of Trainers :

S. No.	Date	Subject	Rating (√)			
			Excellent	Very good	Good	Average
1	11.12.17	speaking	✓			

4. Two positive points about the programme:

very good teaching

5. Suggestions for improvement:

Nothing

Date: 11.12.17 & AN

  
 PRINCIPAL,  
 K. S. R. INSTITUTE FOR  
 ENGINEERING AND TECHNOLOGY,  
 K. S. R. KALVI NAGAR,  
 TIRUCHENGODE - 637 215,  
 NAMAKKAL Dt., TAMIL NADU

Signature

**K S R INSTITUTE FOR ENGINEERING AND TECHNOLOGY  
TIRUCHENGODE - 637 215**

**TRAINING PROGRAMME FEEDBACK FORM**



Name of the Student: S. Stelin hercia

Branch: CSE

Year / Sem: II / IV

1. Name of the Training: Soft skills

2. Name of the Trainer: Muhanthan

3. Students rating of Trainers: 8(10)

S. No.	Date	Subject	Rating (✓)			
			Excellent	Very good	Good	Average
1	11.12.17	English	✓			

4. Two positive points about the programme: More soft skills are learned.  
Many advices are given

5. Suggestions for improvement:

It's enough

Date: 11.12.17

S. Stelin hercia  
Signature

**K S R INSTITUTE FOR ENGINEERING AND TECHNOLOGY  
TIRUCHENGODE - 637 215**

**TRAINING PROGRAMME FEEDBACK FORM**



Name of the Student: N.M. AKSHAYA

Branch: FCE

Year / Sem: II / IV

4. Name of the Training: soft skills

5. Name of the Trainer: Muhanthan

6. Students rating of Trainers: 8(10)

S. No.	Date	Subject	Rating (✓)			
			Excellent	Very good	Good	Average
1	11.12.17	English	✓			

4. Two positive points about the programme: class went interesting  
Got some more points to develop  
The soft skills.

5. Suggestions for improvement:

still little more points

Date: 11.12.17

PRINCIPAL,  
K. S. R. INSTITUTE FOR  
ENGINEERING AND TECHNOLOGY,  
K. S. R. KALLI,  
TIRUCHENGODE - 637 215,  
NAMAKKAL DISTRICT, TAMIL NADU.  
N.M. Akshaya  
Signature

**K S R INSTITUTE FOR ENGINEERING AND TECHNOLOGY  
TIRUCHENGODE - 637 215**

**TRAINING PROGRAMME FEEDBACK FORM**



Name of the Student: M. BRINDHA

Branch: FCE

Year / Sem: II - IV sem

1. Name of the Training: AI CSD

2. Name of the Trainer: S. MADHAN

3. Students rating of Trainers :

S. No.	Date	Subject	Rating (√)			
			Excellent	Very good	Good	Average
1	11/12/17	CSD	✓			

4. Two positive points about the programme:

Teaching was good  
nice clarification

5. Suggestions for improvement:

Nil

S. M.

Signature

Date: 11/10

**K S R INSTITUTE FOR ENGINEERING AND TECHNOLOGY  
TIRUCHENGODE - 637 215**

**TRAINING PROGRAMME FEEDBACK FORM**



Name of the Student: M. PRAVEEN KOMAR

Branch: CSE

Year / Sem: II - IV sem

4. Name of the Training: CSD

5. Name of the Trainer: S. MADHAN

6. Students rating of Trainers :

S. No.	Date	Subject	Rating (√)			
			Excellent	Very good	Good	Average
1	11/12/17	CSD	✓			

4. Two positive points about the programme:

Teaching was good, clear explanation

5. Suggestions for improvement:

Nil

PRINCIPAL,  
K. S. R. INSTITUTE FOR  
ENGINEERING AND TECHNOLOGY  
K. S. R. KOLEY, TIRUCHENGODE,  
TIRUCHENGODE 637 215,  
NAMAKKAL DISTRICT, TAMIL NADU.  
M. Praveen Kumar  
Signature

Date: 11.12.17



Name of the Student: M. Vinoth

Branch: B.Tech IT

Year / Sem: II / 1st

4. Name of the Training :

5. Name of the Trainer : Mohan

6. Students rating of Trainers :

S. No.	Date	Subject	Rating (√)			
			Excellent	Very good	Good	Average
1	12.12.17	English	✓			

4. Two positive points about the programme:

Training was good

5. Suggestions for improvement:

Date: 12.12.17 & AN

M. Vinoth  
Signature

U1 - AN



Name of the Student: J. Velu Perabba

Branch: CSE - AI

Year / Sem: II / 1st

4. Name of the Training : Communication Skills

5. Name of the Trainer : Mohan Sir & Kangaselvam Sir.

6. Students rating of Trainers :

S. No.	Date	Subject	Rating (√)			
			Excellent	Very good	Good	Average
1	12.12.2017	Analogy Vocabulary			✓	

4. Two positive points about the programme:

\* gain many vocabulary

\* Interesting and useful

5. Suggestions for improvement:

\* little bit more

Date: 12/12/17

PRINCIPAL  
K. S. R. INSTITUTE FOR  
ENGINEERING AND TECHNOLOGY,  
K. S. R. KALVI NAGAR,  
TIRUCHENGODE - 637 215,  
NAMAKKAL DISTRICT, TAMIL NADU.

J. Velu Perabba  
Signature

**K S R INSTITUTE FOR ENGINEERING AND TECHNOLOGY  
TIRUCHENGODE - 637 215**

**TRAINING PROGRAMME FEEDBACK FORM**



Name of the Student: A.S. MALATHI

Branch: B.E-ELE

Year / Sem: II / IV

1.Name of the Training : CSD

2.Name of the Trainer : MUHUNTH RAJ

3.Students rating of Trainers :

S. No.	Date	Subject	Rating (✓)			
			Excellent	Very good	Good	Average
1	12/12/17	CSD	✓			

4. Two positive points about the programme: clarification

5. Suggestions for improvement:

Date: 12/12/17

A.S. Malathi  
Signature

**K S R INSTITUTE FOR ENGINEERING AND TECHNOLOGY  
TIRUCHENGODE - 637 215**

**TRAINING PROGRAMME FEEDBACK FORM**



Name of the Student: S. Mohanraj

Branch: B.Tech - IT

Year / Sem: II / IV

4.Name of the Training : CSD

5.Name of the Trainer : Muhuntharajan

6.Students rating of Trainers :

S. No.	Date	Subject	Rating (✓)			
			Excellent	Very good	Good	Average
1	12/12/17	CSD	✓			

4. Two positive points about the programme:

\* teaching is very good

5. Suggestions for improvement:

nothing

Date:

  
**PRINCIPAL,**  
**K. S. R. INSTITUTE FOR**  
**ENGINEERING AND TECHNOLOGY,**  
**K. S. R. KALYANAGAR,**  
**TIRUCHENGODE - 637 215,**  
**NAMAKKAL DISTRICT, TAMIL NADU.**

Signature

109 - 14114111

**K S R INSTITUTE FOR ENGINEERING AND TECHNOLOGY  
TIRUCHENGODE - 637 215**

**TRAINING PROGRAMME FEEDBACK FORM**



Name of the Student: D. Baweena (FN)

Branch: EEE

Year / Sem: II / 3<sup>rd</sup>

1. Name of the Training :

2. Name of the Trainer : Muhunthan

3. Students rating of Trainers :

S. No.	Date	Subject	Rating (✓)			
			Excellent	Very good	Good	Average
1	12.12.17	Soft Skill training in Business and PPTs Excel Proficiency		✓		

4. Two positive points about the programme:

5. Suggestions for improvement:

Date: 12.12.17

D. Baweena  
Signature

(AN)  
**K S R INSTITUTE FOR ENGINEERING AND TECHNOLOGY  
TIRUCHENGODE - 637 215**

**TRAINING PROGRAMME FEEDBACK FORM**



Name of the Student: Rathana kumar

Branch: EEE

Year / Sem: II / 3<sup>rd</sup>

4. Name of the Training :

5. Name of the Trainer : S. Mahan

6. Students rating of Trainers :

S. No.	Date	Subject	Rating (✓)			
			Excellent	Very good	Good	Average
1	12.12.17	Activity 2 Froggy Spelling		✓		

4. Two positive points about the programme:

5. Suggestions for improvement:

Date: 12.12.17

PRINCIPAL,  
K. S. R. INSTITUTE FOR  
ENGINEERING AND TECHNOLOGY,  
K. S. R. KALVI NAGAR,  
TIRUCHENGODE - 637 215,  
NAMAKKAL Dt, TAMIL NADU.

Rathana kumar  
Signature



**K S R INSTITUTE FOR ENGINEERING AND TECHNOLOGY  
TIRUCHENGODE - 637 215**

**TRAINING PROGRAMME FEEDBACK FORM**



Name of the Student: R.Monika

Branch: ECE

Year / Sem: II / III

1.Name of the Training : PIPES AND CISTERNS

2.Name of the Trainer : SURESH

3.Students rating of Trainers :

S. No.	Date	Subject	Rating (✓)			
			Excellent	Very good	Good	Average
1	12/12/17	PIPES AND CISTERNS		✓		

4. Two positive points about the programme:

Pipes and tanks. It gives more knowledge about

5. Suggestions for improvement:

Nothing

*[Signature]*  
Signature

Date:

**K S R INSTITUTE FOR ENGINEERING AND TECHNOLOGY  
TIRUCHENGODE - 637 215**

**TRAINING PROGRAMME FEEDBACK FORM**



Name of the Student: R.Monika

Branch: ECB

Year / Sem: II / III

4.Name of the Training : DISTANCE DIRECTION

5.Name of the Trainer : KUMARAVEL

6.Students rating of Trainers :

S. No.	Date	Subject	Rating (✓)			
			Excellent	Very good	Good	Average
1	12/12/17	DIRECTIONS		✓		

4. Two positive points about the programme:

knowing about directions and distance.

5. Suggestions for improvement:

Nothing

PRINCIPAL,  
K. S. R. INSTITUTE FOR  
ENGINEERING AND TECHNOLOGY,  
K. S. R. KALYAN,  
TIRUCHENGODE,  
NAMAKKAL DISTRICT, TAMIL NADU.  
*[Signature]*  
Signature

Date: 12/12/17

K S R INSTITUTE FOR ENGINEERING AND TECHNOLOGY  
TIRUCHENGODE - 637 215

TRAINING PROGRAMME FEEDBACK FORM



Name of the Student: R. NANDHAKUMARAN

Branch: IV

Year / Sem: 02/04

1. Name of the Training : Problems on ages

2. Name of the Trainer : Sivakumar.

3. Students rating of Trainers :

S. No.	Date	Subject	Rating (✓)			
			Excellent	Very good	Good	Average
1	12.12.17	APPTITUDE.	✓			

15.

4. Two positive points about the programme:

- ⇒ makes interesting and active.
- ⇒ Got different ideas on different problems.

5. Suggestions for improvement:

Difficult to understand the questions. Need practice & more problems to solve quickly.

Date: 12.12.17

R. Nadhakumar  
Signature

K S R INSTITUTE FOR ENGINEERING AND TECHNOLOGY  
TIRUCHENGODE - 637 215

TRAINING PROGRAMME FEEDBACK FORM



Name of the Student: R. NANDHAKUMARAN

Branch: IV

Year / Sem: 02/04

4. Name of the Training : Partnership

5. Name of the Trainer : Jawitha.

6. Students rating of Trainers :

S. No.	Date	Subject	Rating (✓)			
			Excellent	Very good	Good	Average
1	12.12.17	APPTITUDE.		✓		

20.

4. Two positive points about the programme:

- ⇒ Easy understanding
- ⇒ Simple to solve.

5. Suggestions for improvement:

Slow teaching. Need solving the problems.

Date: 12.12.17

PRINCIPAL,  
K. S. R. INSTITUTE FOR  
ENGINEERING AND TECHNOLOGY,  
K. S. R. KALVI NAGAR,  
TIRUCHENGODE - 637 215,  
NAMAKKAL DISTRICT, TAMIL NADU.  
R. Nadhakumar  
Signature

**K S R INSTITUTE FOR ENGINEERING AND TECHNOLOGY  
TIRUCHENGODE - 637 215**

**TRAINING PROGRAMME FEEDBACK FORM**



Name of the Student: Divya Devi. V.

Branch: EEE

Year / Sem: II / IV

1. Name of the Training: Problems of Age

2. Name of the Trainer: Mr Sivakumar.

3. Students rating of Trainers :

S. No.	Date	Subject	Rating (√)			
			Excellent	Very good	Good	Average
1	12.12.2017	Maths		✓		

4. Two positive points about the programme:

\* Easy to understand.

\* Excellent explaining.

5. Suggestions for improvement:

Date: 12.12.17

V. Divya

Signature

**K S R INSTITUTE FOR ENGINEERING AND TECHNOLOGY  
TIRUCHENGODE - 637 215**

**TRAINING PROGRAMME FEEDBACK FORM**



Name of the Student: Sujitha. E

Branch: EEE

Year / Sem: II / IV

4. Name of the Training: Partnership.

5. Name of the Trainer: Mrs. R. Kavitha.

6. Students rating of Trainers :

S. No.	Date	Subject	Rating (√)			
			Excellent	Very good	Good	Average
1	12.12.17	Appitude	✓			

4. Two positive points about the programme:

\* Easy to understand.

\* Topic is very easy

5. Suggestions for improvement:

Nothing

Date: 12.12.17

compare to other topics.

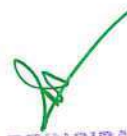
  
**PRINCIPAL**  
**K. S. R. INSTITUTE FOR ENGINEERING AND TECHNOLOGY,**  
**K. S. R. KALINAGAR,**  
**TIRUCHENGODE - 637 215**  
**NAMAKKAL DISTRICT.**

E. Sujitha

Signature

K S R I NSTITUTE FOR ENGINEERING AND TECHNOLOGY  
TIRUCHENGODE - 637 215

TRAINING PROGRAMME FEEDBACK FORM



Name of the Student: Kavin Kumar

Branch: EE

Year / Sem: OB III / IV

1. Name of the Training: placement training

2. Name of the Trainer :

3. Students rating of Trainers :

S. No.	Date	Subject	Rating (✓)			
			Excellent	Very good	Good	Average
1	13/12/2017	APRS	✓			

4. Two positive points about the programme:   
 1) slowly taught   
 2) well good about question
5. Suggestions for improvement:   
 1) interest about in excellence.

Date:

Signature

K S R I NSTITUTE FOR ENGINEERING AND TECHNOLOGY  
TIRUCHENGODE - 637 215

TRAINING PROGRAMME FEEDBACK FORM



Name of the Student: J. Kausalya

Branch: B.Tech - IT

Year / Sem: 2016-2020 14<sup>th</sup> rd

1. Name of the Training : clock

2. Name of the Trainer : P. Sivakumar

3. Students rating of Trainers :

S. No.	Date	Subject	Rating (✓)			
			Excellent	Very good	Good	Average
1	13/12/17	clock	✓			

4. Two positive points about the programme:   
 Excellent training   
 Improve our knowledge
5. Suggestions for improvement:   
 Nil

Date:

  
 PRINCIPAL,  
 K. S. R. INSTITUTE FOR  
 ENGINEERING AND TECHNOLOGY,  
 K. S. P. KALVI NAGAR,  
 TIRUCHENGODE - 637 215,  
 NAMAIGAL DI, TAMIL NADU.  
 Signature

K S R INSTITUTE FOR ENGINEERING AND TECHNOLOGY  
TIRUCHENGODE - 637 215

TRAINING PROGRAMME FEEDBACK FORM



Name of the Student: V. Viji

Branch: B.Tech-17

Year / Sem:

1. Name of the Training: Excursion (Clock & Clander)

2. Name of the Trainer: SIVA KUMAR

3. Students rating of Trainers :

S. No.	Date	Subject	Rating (√)			
			Excellent	Very good	Good	Average
1	13.12.17	App			✓	

4. Two positive points about the programme:

Excellent Training

5. Suggestions for improvement:

nil.

Date: 13.12.17

Signature

V. Viji

K S R INSTITUTE FOR ENGINEERING AND TECHNOLOGY  
TIRUCHENGODE - 637 215

TRAINING PROGRAMME FEEDBACK FORM



Name of the Student: S. Malavika

Branch: B.Tech (IT)

Year / Sem: III / IV

1. Name of the Training: Aptitude

2. Name of the Trainer: Sivakumar

3. Students rating of Trainers :

S. No.	Date	Subject	Rating (√)			
			Excellent	Very good	Good	Average
1	13.12.17	Maths			✓	

4. Two positive points about the programme:

\* Good Teacher /

5. Suggestions for improvement:

Date:

Signature

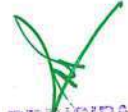
  
PRINCIPAL,  
K. S. R. INSTITUTE FOR  
ENGINEERING AND TECHNOLOGY,  
K. S. R. KALVI NAGAR,  
TIRUCHENGODE - 637 215,  
NAMAKKAL DISTRICT, TAMIL NADU.



Name of the Student: M. Praveen Kumar

Branch: ESE

Year / Sem: II / IV

4. Name of the Training: Aptitude Pipes and Cisterns

5. Name of the Trainer: Suresh

6. Students rating of Trainers :

S. No.	Date	Subject	Rating (√)			
			Excellent	Very good	Good	Average
1	16/12/17	maths	✓			

4. Two positive points about the programme:

understand clearly, good

5. Suggestions for improvement:

Date: 16/12/17

M. Praveen Kumar  
Signature



Name of the Student: A. S. MALATHI

Branch: B.E - ECE

Year / Sem: II / IV

1. Name of the Training: ~~KUMARAVEL~~ DIRECTIONS

2. Name of the Trainer: KUMARAVEL

3. Students rating of Trainers :

S. No.	Date	Subject	Rating (√)			
			Excellent	Very good	Good	Average
1	15/12/17	Aptitude	✓			

4. Two positive points about the programme:

1. Nice clarification  
2. Not bored, interested

5. Suggestions for improvement:

Date: 15/12/2017

A. S. Malathi  
PRINCIPAL,  
K. S. R. INSTITUTE FOR  
ENGINEERING AND TECHNOLOGY,  
K. S. R. KALVI NAGAR,  
TIRUCHENGODE - 637 215,  
NAMAKKAL DISTRICT, TAMIL NADU.

Signature

FORM NO. 007

**K S R INSTITUTE FOR ENGINEERING AND TECHNOLOGY**  
TIRUCHENGODE - 637 215

**TRAINING PROGRAMME FEEDBACK FORM**



(FN)

Name of the Student: S. SAKTHIPRIYA Branch: ECE

Year / Sem: II / IV

1. Name of the Training: Communication

2. Name of the Trainer: P. Mohan.

3. Students rating of Trainers :

S. No.	Date	Subject	Rating (✓)			
			Excellent	Very good	Good	Average
1	13.12.17	Speaking, Self intro	✓			

4. Two positive points about the programme:

5. Suggestions for improvement:

Date: 13.12.17

*S. Sakthipriya*  
Signature

**K S R INSTITUTE FOR ENGINEERING AND TECHNOLOGY**  
TIRUCHENGODE - 637 215

**TRAINING PROGRAMME FEEDBACK FORM**



(AN)

Name of the Student: M. PRAVEENA Branch: ECE

Year / Sem: II / IV

4. Name of the Training: R. Kanagaselvan (Communication)

5. Name of the Trainer :

6. Students rating of Trainers :

S. No.	Date	Subject	Rating (✓)			
			Excellent	Very good	Good	Average
1	13.12.17	Revision	✓			

4. Two positive points about the programme:

5. Suggestions for improvement:

Date: 13.12.17

**PRINCIPAL,**  
**K. S. R. INSTITUTE FOR**  
**ENGINEERING AND TECHNOLOGY,**  
**K. S. R. KALVI NAGAR,**  
**TIRUCHENGODE - 637 215,**  
**NAMAKKAL DL, TAMIL NADU.**  
*M. Pr...*  
Signature

K S R INSTITUTE FOR ENGINEERING AND TECHNOLOGY  
TIRUCHENGODE - 637 215



TRAINING PROGRAMME FEEDBACK FORM

Name of the Student: S. Yogesh

Branch: FCE

Year / Sem: II / III

- 1. Name of the Training : Module - 5
- 2. Name of the Trainer : Mr. Kanagaselvam sir
- 3. Students rating of Trainers : 5

S. No.	Date	Subject	Rating (✓)			
			Excellent	Very good	Good	Average
1	13.12.17	Communication	✓			

4. Two positive points about the programme: Easy to understand.  
Friendly type

5. Suggestions for improvement: add games in the beggung

Yogesh  
Signature

Date: 13.12.17

K S R INSTITUTE FOR ENGINEERING AND TECHNOLOGY  
TIRUCHENGODE - 637 215



TRAINING PROGRAMME FEEDBACK FORM

Name of the Student: R.S. Vasu MITHA

Branch: CSE

Year / Sem: II / II

- 4. Name of the Training : Module - 5
- 5. Name of the Trainer : Mr. Kanagaselvam
- 6. Students rating of Trainers : 5

S. No.	Date	Subject	Rating (✓)			
			Excellent	Very good	Good	Average
1	13.12.17	Communication	✓			

4. Two positive points about the programme: Had a great conversation with our teammat  
we can able to undustand their personal life and charac  
of my teammate

5. Suggestions for improvement: - Nil -

**PRINCIPAL,**  
**K. S. R. INSTITUTE FOR**  
**ENGINEERING AND TECHNOLOGY,**  
**K. S. R. KALVAYAR,**  
**TIRUCHENGODE - 637 215,**  
**NAMAKKAL Dt, TAMIL NADU.**

Date: 13.12.17



K S R INSTITUTE FOR ENGINEERING AND TECHNOLOGY  
TIRUCHENGODE - 637 215

TRAINING PROGRAMME FEEDBACK FORM



Name of the Student: S. Devi Gayathri Branch: CSE

Year / Sem: I / 4

1. Name of the Training: Communication skills (speaking)

2. Name of the Trainer: Mr. Kanaga selvam

3. Students rating of Trainers: S. Nivetha, S. Bhavyashree, S. Devi Gayathri.

S. No.	Date	Subject	Rating (✓)			
			Excellent	Very good	Good	Average
1	13.12.17	Communication skills (speaking)		✓		

4. Two positive points about the programme: \* We could able to speak in English \* Everyone has participated

5. Suggestions for improvement: \* Give Innovative activities

Date: 13.12.17

S. Devi Gayathri  
Signature

K S R INSTITUTE FOR ENGINEERING AND TECHNOLOGY  
TIRUCHENGODE - 637 215

TRAINING PROGRAMME FEEDBACK FORM



Name of the Student: Virek V Branch: FEE

Year / Sem: II / IV

4. Name of the Training: Communication skills

5. Name of the Trainer: Mr. Mohan Mr. Kanaga selvam

6. Students rating of Trainers:

S. No.	Date	Subject	Rating (✓)			
			Excellent	Very good	Good	Average
1	13.12.17	Communication Analogy skills		✓		

4. Two positive points about the programme: \* New point of communication \* Usage of 2 words or more with same meaning

5. Suggestions for improvement: Games can be played

Date: 13-12-17

**PRINCIPAL,**  
**K. S. R. INSTITUTE FOR**  
**ENGINEERING AND TECHNOLOGY,**  
**K. S. R. KALVI NAGAR,**  
**TIRUCHENGODE - 637 215,**  
**NAMAKKAL Dt, TAMIL NADU.**  
Signature [Signature]

**K S R INSTITUTE FOR ENGINEERING AND TECHNOLOGY  
TIRUCHENGODE - 637 215**

**TRAINING PROGRAMME FEEDBACK FORM**



Name of the Student: S. Sabin

Branch: EEE

Year / Sem: II/IV

1. Name of the Training : Pipes & Cistern

2. Name of the Trainer : Mr. Suresh

3. Students rating of Trainers :

S. No.	Date	Subject	Rating (✓)			
			Excellent	Very good	Good	Average
1	13.12.17	Mathematics	✓			

4. Two positive points about the programme: 10 questions  
Good Teaching  
Easy to learn

5. Suggestions for improvement: -

Date: 13.12.17

S. Sabin  
Signature

**K S R INSTITUTE FOR ENGINEERING AND TECHNOLOGY  
TIRUCHENGODE - 637 215**

**TRAINING PROGRAMME FEEDBACK FORM**



Name of the Student: N. Syed Salim

Branch: FCE

Year / Sem: II/IV

4. Name of the Training : Pipes & Cistern

5. Name of the Trainer : P. Devi Sri

6. Students rating of Trainers :

S. No.	Date	Subject	Rating (✓)			
			Excellent	Very good	Good	Average
1	13.12.17	Mathematics	✓			

4. Two positive points about the programme: Easy to understand  
Many methods learn

5. Suggestions for improvement: -

Date: 13.12.17

**PRINCIPAL,  
K. S. R. INSTITUTE FOR  
ENGINEERING AND TECHNOLOGY,  
K. S. R. KALVI NAGAR,  
TIRUCHENGODE - 637 215,  
NAMAKKAL Dt, TAMIL NADU.**

N. S. S. S.  
Signature

209

K S R INSTITUTE FOR ENGINEERING AND TECHNOLOGY  
TIRUCHENGODE - 637 215

TRAINING PROGRAMME FEEDBACK FORM



Name of the Student: R. Janani

Branch: B. Tech IT

Year / Sem: II / IV

1. Name of the Training : pipes and cisterns

2. Name of the Trainer : Mr. Suresh.

3. Students rating of Trainers :

S. No.	Date	Subject	Rating (✓)			
			Excellent	Very good	Good	Average
1	13.12.17	Maths		✓		

10 questions

4. Two positive points about the programme:

Not bored

easy to simplify the sums

5. Suggestions for improvement:

Date: 13.11.2017

R. Anj  
Signature

K S R INSTITUTE FOR ENGINEERING AND TECHNOLOGY  
TIRUCHENGODE - 637 215

TRAINING PROGRAMME FEEDBACK FORM



Name of the Student: K. Dharani

Branch: B.E - CSE

Year / Sem: II / 04

4. Name of the Training : clocks & calendars

5. Name of the Trainer : P. Devsri

6. Students rating of Trainers :

S. No.	Date	Subject	Rating (✓)			
			Excellent	Very good	Good	Average
1	13.12.17	Maths.		✓		

4. Two positive points about the programme:

Very useful to revise once.

Used in clarifying our doubts.

5. Suggestions for improvement:

Date: 13.11.2017

PRINCIPAL,  
K. S. R. INSTITUTE FOR  
ENGINEERING AND TECHNOLOGY,  
K. S. R. KALVI NAGAR,  
TIRUCHENGODE - 637 215,  
NAMAKKAL Dt, TAMIL NADU.

K. Dharani  
Signature

1207

**K S R INSTITUTE FOR ENGINEERING AND TECHNOLOGY  
TIRUCHENGODE - 637 215**

**TRAINING PROGRAMME FEEDBACK FORM**



Name of the Student: RAJA RAJAN . A

Branch: CSE

Year / Sem: II / IV

1. Name of the Training : PLACEMENT TRAINING

2. Name of the Trainer : KULANDHA VELU

3. Students rating of Trainers : 4/5

S. No.	Date	Subject	Rating (✓)			
			Excellent	Very good	Good	Average
1	13.12.17 (FN)	PROBLEM ON AGES			✓	

4. Two positive points about the programme: \* Good coaching, to get clarification on basic.

5. Suggestions for improvement: NIL

Signature

Date: 13.12.17

**K S R INSTITUTE FOR ENGINEERING AND TECHNOLOGY  
TIRUCHENGODE - 637 215**

**TRAINING PROGRAMME FEEDBACK FORM**



Name of the Student: RAJA RAJAN - A

Branch: CSE

Year / Sem: II / IV

4. Name of the Training : PLACEMENT TRAINING

5. Name of the Trainer : KAVITHA

6. Students rating of Trainers :

S. No.	Date	Subject	Rating (✓)			
			Excellent	Very good	Good	Average
1	13.12.17 (AN)	ASSESSMENT TEST	TEST	DISCUSSION		

DISCUSSION

4. Two positive points about the programme:



5. Suggestions for improvement: —

**PRINCIPAL,  
K. S. R. INSTITUTE FOR  
ENGINEERING AND TECHNOLOGY,  
K. S. R. KALVI NAGAR,  
TIRUCHENGODE - 637 215,  
NAMAKKAL Dt, TAMIL NADU.**

Signature

Date: 13.12.17



TRAINING PROGRAMME FEEDBACK FORM

Name of the Student: JATHA.S

Branch: EEE

Year / Sem: II / IV

1.Name of the Training : Aptitude

2.Name of the Trainer : Kulandaivelu

3.Students rating of Trainers :

S. No.	Date	Subject	Rating (✓)			
			Excellent	Very good	Good	Average
1	13.11.17	Problems on Ages			✓	

4. Two positive points about the programme: Very effective

Easy to understand

5. Suggestions for improvement:

Nil

Date: 13.11.17

[Signature]  
Signature



TRAINING PROGRAMME FEEDBACK FORM

Name of the Student: SUVEETHA.T

Branch: EEE

Year / Sem: II / IV

4.Name of the Training : Aptitude

5.Name of the Trainer :

6.Students rating of Trainers :

S. No.	Date	Subject	Rating (✓)			
			Excellent	Very good	Good	Average
1	13.11.17	Partnership			✓	

4. Two positive points about the programme:

Good

5. Suggestions for improvement:

Date: 13.11.17

[Signature]  
PRINCIPAL,  
K. S. R. INSTITUTE FOR  
ENGINEERING AND TECHNOLOGY,  
K. S. R. KALVI NAGAR,  
TIRUCHENGODE - 637 215,  
NAMAKKAL DT, TAMIL NADU.

[Signature]  
Signature

**TIRUCHENGODE - 637 215**  
**TRAINING PROGRAMME FEEDBACK FORM**



Name of the Student: Naveen. k. s

Branch: ECE - B

Year / Sem: II / IV

4. Name of the Training: Soft skills

5. Name of the Trainer: Mohan

6. Students rating of Trainers :

S. No.	Date	Subject	Rating (✓)			
			Excellent	Very good	Good	Average
1	14/12/17	English			✓	

4. Two positive points about the programme:

Interesting idea to improve communication  
skill

5. Suggestions for improvement:

Date: 14/12/2017

Mohan  
Signature

**K S R INSTITUTE FOR ENGINEERING AND TECHNOLOGY**  
**TIRUCHENGODE - 637 215**  
**TRAINING PROGRAMME FEEDBACK FORM**



Name of the Student: S. flakya

Branch: ECE

Year / Sem: II / IV

4. Name of the Training: Partnership

5. Name of the Trainer: Mr. Jayakumar

6. Students rating of Trainers :

S. No.	Date	Subject	Rating (✓)			
			Excellent	Very good	Good	Average
1	14/12/17	Maths		✓		

4. Two positive points about the programme: \* Explained very clearly  
 \* Taught without getting boring

5. Suggestions for improvement: NO

Date: 14/12/17

**PRINCIPAL,**  
**K. S. R. INSTITUTE FOR**  
**ENGINEERING AND TECHNOLOGY,**  
**K. S. R. KALVI NAGAR,**  
**TIRUCHENGODE - 637 215,**  
**NAMAKKAL DI, TAMIL NADU.**

[Signature]  
Signature



Name of the Student: S. Mounika

Branch: B.Tech/IT

Year / Sem: II / IV

4. Name of the Training: Basic Grammar and soft skill development course

5. Name of the Trainer: Madhan

6. Students rating of Trainers: Good

S. No.	Date	Subject	Rating (√)			
			Excellent	Very good	Good	Average
1	14.12.17	English	✓			

4. Two positive points about the programme:

\* Good teaching

5. Suggestions for improvement:

Date: 14.12.17

S. Mounika  
Signature



Name of the Student: R. Pooiyanka

Branch: CSF

Year / Sem: II / IV

4. Name of the Training: Basic Grammar and Soft skills development

5. Name of the Trainer: Madhan

6. Students rating of Trainers: Good

S. No.	Date	Subject	Rating (√)			
			Excellent	Very good	Good	Average
1	14.12.17	English	✓			

4. Two positive points about the programme:

5. Suggestions for improvement:

Date:

[Signature]  
PRINCIPAL,  
K. S. R. INSTITUTE FOR  
ENGINEERING AND TECHNOLOGY,  
K. S. R. KALVI NAGAR,  
TIRUCHENGODE - 637 215,  
NAMAKKAL Dt, TAMIL NADU.

[Signature]  
Signature

**K S R INSTITUTE FOR ENGINEERING AND TECHNOLOGY  
TIRUCHENGODE - 637 215**

**TRAINING PROGRAMME FEEDBACK FORM**



Name of the Student: N. POORNIMA Branch: ECE

Year / Sem: II - IV

1. Name of the Training : PLACEMENT TRAINING

2. Name of the Trainer : KULANDAI VELU

3. Students rating of Trainers :

S. No.	Date	Subject	Rating (✓)			
			Excellent	Very good	Good	Average
1	14/12/17	MATHS	✓			

4. Two positive points about the programme:

*Good explanation*

5. Suggestions for improvement:

*Nice clarity*

*Poornima N*

Date:

Signature

**K S R INSTITUTE FOR ENGINEERING AND TECHNOLOGY  
TIRUCHENGODE - 637 215**

**TRAINING PROGRAMME FEEDBACK FORM**



Name of the Student: T. Janani Branch: IT

Year / Sem: II / 04

4. Name of the Training : calendars & clocks (Aptitude)

5. Name of the Trainer : SIVAKUMAR

6. Students rating of Trainers :

S. No.	Date	Subject	Rating (✓)			
			Excellent	Very good	Good	Average
1	14/12/17	MATHS	✓			

4. Two positive points about the programme:

*Good explanation*

*Good teaching*

5. Suggestions for improvement:

**PRINCIPAL,  
K. S. R. INSTITUTE FOR  
ENGINEERING AND TECHNOLOGY,  
K. S. R. KALVI NAGAR,  
TIRUCHENGODE - 637 215,  
NAMAKKAL DL, TAMIL NADU.**

Date:

*T. Janani*  
Signature



K S R INSTITUTE FOR ENGINEERING AND TECHNOLOGY  
TIRUCHENGODE - 637 215

TRAINING PROGRAMME FEEDBACK FORM



Name of the Student: P. Thangavel

Branch: ECE

Year / Sem: II / IV (FN)

1. Name of the Training: Aptitude

2. Name of the Trainer: Kumaravel

3. Students rating of Trainers :

S. No.	Date	Subject	Rating (√)			
			Excellent	Very good	Good	Average
1	14.12.17	Mathematics		✓		

4. Two positive points about the programme:

5. Suggestions for improvement:

Date: 14.12.17

(AN)

P. Thangavel  
Signature

K S R INSTITUTE FOR ENGINEERING AND TECHNOLOGY  
TIRUCHENGODE - 637 215

TRAINING PROGRAMME FEEDBACK FORM



Name of the Student: R. Anubhavan

Branch: ECE - A

Year / Sem: II / IV

4. Name of the Training: Aptitude

5. Name of the Trainer: Kulandhavelu

6. Students rating of Trainers :

S. No.	Date	Subject	Rating (√)			
			Excellent	Very good	Good	Average
1	14.12.17	Mathematics	✓			

4. Two positive points about the programme:

5. Suggestions for improvement:

Date: 14.12.17

PRINCIPAL,  
K. S. R. INSTITUTE FOR  
ENGINEERING AND TECHNOLOGY,  
K. S. R. KALVI NAGAR,  
TIRUCHENGODE - 637 215,  
NAMAKKAL Dt, TAMIL NADU.

R. Anubhavan  
Signature



Name of the Student: R. Sumanthi Branch: ECE

Year / Sem: II - 4

1. Name of the Training: Soft skills development

2. Name of the Trainer: Madhan

3. Students rating of Trainers :

S. No.	Date	Subject	Rating (✓)			
			Excellent	Very good	Good	Average
1	14.12.17	Antonyms words, Exious		✓		

4. Two positive points about the programme: easyly understand

5. Suggestions for improvement: Interesting

Date: 14.12.17 break give a time to felt answer  
Signature: R. Sumanthi



Name of the Student: T. Dhanya Branch: ECE

Year / Sem: II - IV

4. Name of the Training: Soft skills development

5. Name of the Trainer: Mohan

6. Students rating of Trainers :

S. No.	Date	Subject	Rating (✓)			
			Excellent	Very good	Good	Average
1	14/12/17	MODULE I Soft skills		✓		

4. Two positive points about the programme: I learn many thing

5. Suggestions for improvement: easyly understand

Date: 14/12/17 give a break

**PRINCIPAL,**  
**K. S. R. INSTITUTE FOR**  
**ENGINEERING AND TECHNOLOGY,**  
**K. S. R. KALVI NAGAR,**  
**TIRUCHENGODE - 637 215,**  
**NAMAKKAL DISTRICT, TAMIL NADU.**  
 Signature

K S R INSTITUTE FOR ENGINEERING AND TECHNOLOGY  
TIRUCHENGODE - 637 215

TRAINING PROGRAMME FEEDBACK FORM



Name of the Student: KAMALI SOUNBARYA.B

Branch: EEF

Year / Sem: II / IV

1. Name of the Training: Basic Grammar and soft skills Development

2. Name of the Trainer: Karagaselvam

3. Students rating of Trainers :

S. No.	Date	Subject	Rating (√)			
			Excellent	Very good	Good	Average
1	14.12.17	Module - 5			✓	

4. Two positive points about the programme:

well and good.

5. Suggestions for improvement:

Interact more with us

Kamal Sounbarya  
Signature

Date: 14.12.17

K S R INSTITUTE FOR ENGINEERING AND TECHNOLOGY  
TIRUCHENGODE - 637 215

TRAINING PROGRAMME FEEDBACK FORM



Name of the Student: PREEETHA.B

Branch: EEF

Year / Sem: II / IV

4. Name of the Training: Basic Grammar & soft skills Development

5. Name of the Trainer: Karagaselvam.

6. Students rating of Trainers :

S. No.	Date	Subject	Rating (√)			
			Excellent	Very good	Good	Average
1	14.12.17	Module - 4			✓	

4. Two positive points about the programme:

Good. ✓

5. Suggestions for improvement:

PRINCIPAL,  
K. S. R. INSTITUTE FOR  
ENGINEERING AND TECHNOLOGY,  
K. S. R. KALVI NAGAR,  
TIRUCHENGODE - 637 215,  
NAMAKKAL DL, TAMIL NADU.

Preeetha  
Signature

Date: 14.12.17



Name of the Student: S. BHAVYASHREE

Branch: F.C.E

Year / Sem: II - 2<sup>nd</sup>

1. Name of the Training: KUMARAVELUN DIRECTIONS

2. Name of the Trainer: KUMARAVELUN

3. Students rating of Trainers: BHAVYASHREE

S. No.	Date	Subject	Rating (✓)			
			Excellent	Very good	Good	Average
1	14.12.17	Maths		✓		

4. Two positive points about the programme:

\* We learned a lot in Direction  
\* Activities conducted was good.

5. Suggestions for improvement:

\* ~~to~~ Can give brief explanation.

Date:

Signature



Name of the Student: T. ROshini

Branch: ECE

Year / Sem: II / III

4. Name of the Training: DIRECTIONS

5. Name of the Trainer: KUMARAVELUN

6. Students rating of Trainers: ROSHINI

S. No.	Date	Subject	Rating (✓)			
			Excellent	Very good	Good	Average
1	14.12.17	Maths		✓		

4. Two positive points about the programme:

way of teaching is good  
Activities is good

5. Suggestions for improvement:

can give simple explanation

Date: 15.12.17

PRINCIPAL,  
K. S. R. INSTITUTE FOR  
ENGINEERING AND TECHNOLOGY, Signature  
K. S. R. KALVI NAGAR,  
TIRUCHENGODE - 637 215,  
NAMAKKAL Dt, TAMIL NADU.

T. Rojhu



Name of the Student: G. Srinathi Branch: FCE

Year / Sem: II - 4<sup>th</sup>

1. Name of the Training: Basic grammar and soft skills

2. Name of the Trainer: Mr. Madhan

3. Students rating of Trainers :

S. No.	Date	Subject	Rating (✓)			
			Excellent	Very good	Good	Average
1	15.12.2017	MODULE 3	✓			

4. Two positive points about the programme:

1. improve our's skills
2. It's good to increase our English knowledge.

5. Suggestions for improvement:

Date: 15.12.2017

G. Srinathi  
Signature



Name of the Student: G. Srinathi Branch: FCE

Year / Sem: II - 4<sup>th</sup>

4. Name of the Training: Basic grammar and soft skills

5. Name of the Trainer: Mr. Mohan

6. Students rating of Trainers :

S. No.	Date	Subject	Rating (✓)			
			Excellent	Very good	Good	Average
1	15.12.17	MODULE-2	✓			

4. Two positive points about the programme:

1. improve our's vocabulary.
2. It's good to increase our English knowledge.

5. Suggestions for improvement:

Date: 15.12.2017

PRINCIPAL,  
K. S. R. INSTITUTE FOR  
ENGINEERING AND TECHNOLOGY,  
K. S. R. KALVI NAGAR,  
TIRUCHENGODE - 637 215,  
NAMAKKAL Dt, TAMIL NADU.

G. Srinathi  
Signature

K S R INSTITUTE FOR ENGINEERING AND TECHNOLOGY  
TIRUCHENGODE - 637 215

TRAINING PROGRAMME FEEDBACK FORM



Name of the Student: S. Kausalya

Branch: 15/12/17

Year / Sem: I - 4<sup>th</sup>

1. Name of the Training: Module - A ⇒ Analog

2. Name of the Trainer: Kanagaselvam

3. Students rating of Trainers: ★★★★

S. No.	Date	Subject	Rating (✓)			
			Excellent	Very good	Good	Average
1	15/12/17			✓		

4. Two positive points about the programme: ,

Good Teaching

5. Suggestions for improvement:

Nil

Date:

  
Signature

K S R INSTITUTE FOR ENGINEERING AND TECHNOLOGY  
TIRUCHENGODE - 637 215

TRAINING PROGRAMME FEEDBACK FORM



Name of the Student: M. S. Sathyan Hossain Branch: \_\_\_\_\_

Year / Sem: II / IV

4. Name of the Training: Placement training / Communication skills.

5. Name of the Trainer: Kanagaselvam.

6. Students rating of Trainers: ~~Kanagaselvam~~ 4 Stars.

S. No.	Date	Subject	Rating (✓)			
			Excellent	Very good	Good	Average
1	15.12.2017	Communication skills		✓		

4. Two positive points about the programme:

→ Grammar spoken is good.  
→ Speaking skills is good.

5. Suggestions for improvement:

Nothing

Date: 15.12.2017

PRINCIPAL,  
K. S. R. INSTITUTE FOR  
ENGINEERING AND TECHNOLOGY,  
K. S. R. KALVI NAGAR,  
TIRUCHENGODE - 637 215,  
NAMAKKAL DL, TAMIL NADU.

  
Signature

TRAINING PROGRAMME FEEDBACK FORM

Name of the Student: R. kanimozhi

Branch: ECE

Year / Sem: II / IV

4. Name of the Training: Ability partnership

5. Name of the Trainer: Jayakumar

6. Students rating of Trainers :

S. No.	Date	Subject	Rating (✓)			
			Excellent	Very good	Good	Average
1	15/12/2017	Maths		✓		

4. Two positive points about the programme: explanation is easy to understand.

5. Suggestions for improvement:

Speak loudly

Date: 15/12/17.

R. kanimozhi  
Signature

  
PRINCIPAL,  
K. S. R. INSTITUTE FOR  
ENGINEERING AND TECHNOLOGY,  
K. S. R. KALVI NAGAR,  
TIRUCHENGODE - 637 215,  
NAMAKKAL Dt, TAMIL NADU.

**TRAINING PROGRAMME FEEDBACK FORM**



Name of the Student: B. Janani

Branch: B.Tech-IT

Year / Sem: II - IV

1. Name of the Training : communication & soft skills development.

2. Name of the Trainer : Kanaga Selvam.

3. Students rating of Trainers :

S. No.	Date	Subject	Rating (✓)			
			Excellent	Very good	Good	Average
1	15.12.17	English		✓		

4. Two positive points about the programme:

Not boring and easily observed.

5. Suggestions for improvement:

Date:

R. Prinj  
Signature

**TRAINING PROGRAMME FEEDBACK FORM**



Name of the Student: D. Janani

Branch: B.Tech-IT

Year / Sem: II - IV

4. Name of the Training : Soft Skills

5. Name of the Trainer :

6. Students rating of Trainers :

S. No.	Date	Subject	Rating (✓)			
			Excellent	Very good	Good	Average
1	15.12.17	English		✓		

4. Two positive points about the programme:

Very useful

5. Suggestions for improvement:

Date: 15.12.17

**PRINCIPAL,  
K. S. R. INSTITUTE FOR  
ENGINEERING AND TECHNOLOGY,  
K. S. R. KALVI NAGAR,  
TIRUCHENGODE - 637 215,  
NAMAKKAL DI, TAMIL NADU.**

R. Prinj  
Signature



TRAINING PROGRAMME FEEDBACK FORM



Name of the Student: V. Karthikeyan

Branch: ECF

Year / Sem: II / 04

1. Name of the Training: Analogy

2. Name of the Trainer: Kanagasolvam

3. Students rating of Trainers :

S. No.	Date	Subject	Rating (✓)			
			Excellent	Very good	Good	Average
1	<u>18.12.17</u>	<u>English</u>	✓			

4. Two positive points about the programme: Good learning

5. Suggestions for improvement: -

Date: 18.12.17

Signature

TRAINING PROGRAMME FEEDBACK FORM



Name of the Student: M. Priyadharsini

Branch: ECE

Year / Sem: II - IV

4. Name of the Training: Synonyms

5. Name of the Trainer: Mohan

6. Students rating of Trainers :

S. No.	Date	Subject	Rating (✓)			
			Excellent	Very good	Good	Average
1	<u>15.12.17</u>	<u>English</u>		✓		

4. Two positive points about the programme: very useful

5. Suggestions for improvement: -

Date: 15.12.17

PRINCIPAL,  
K. S. R. INSTITUTE FOR  
ENGINEERING AND TECHNOLOGY,  
K. S. R. KALVI NAGAR,  
TIRUCHENGODE - 637 215,  
NAMAKKAL Dt, TAMIL NADU.

M. Priyadharsini  
Signature



Name of the Student: V. YAKSHEETHA

Branch: B.Tech/IT

Year / Sem: II / IV

1. Name of the Training : Check and calibration

2. Name of the Trainer : Devi Sri

3. Students rating of Trainers :

S. No.	Date	Subject	Rating (✓)			
			Excellent	Very good	Good	Average
1	15.12.17	Aptitude	✓			

4. Two positive points about the programme: Easy to understand, friendly to students.

5. Suggestions for improvement:

Date: 15.12.17

V. Yaksheetha  
Signature



Name of the Student: S. S. Devadharshini

Branch: B.E / CSE

Year / Sem: II / IV

4. Name of the Training : pipe and cisterns

5. Name of the Trainer : Suresh

6. Students rating of Trainers :

S. No.	Date	Subject	Rating (✓)			
			Excellent	Very good	Good	Average
1	15.12.17	Aptitude	✓			

4. Two positive points about the programme: Easy to understand, give More Information.

5. Suggestions for improvement:

Date: 15.12.17

**PRINCIPAL,**  
**K. S. R. INSTITUTE FOR**  
**ENGINEERING AND TECHNOLOGY,**  
**K. S. R. KALVI NAGAR,**  
**TIRUCHENGODE - 637 215,**  
**NAMAKKAL Dt, TAMIL NADU.**

S. S. Devadharshini  
Signature

112

**K S R INSTITUTE FOR ENGINEERING AND TECHNOLOGY  
TIRUCHENGODE - 637 215**

**TRAINING PROGRAMME FEEDBACK FORM**



Name of the Student: GI Akilan

Branch: EEE

Year / Sem: II / IV

1. Name of the Training: Problems on Ages

2. Name of the Trainer: Mulaithai velu

3. Students rating of Trainers :

S. No.	Date	Subject	Rating (√)			
			Excellent	Very good	Good	Average
1	15.12.17	Maths		✓		

4. Two positive points about the programme: 1. Full interactive class  
2. learnt more basic formula

5. Suggestions for improvement: None

GI Akilan

Signature

Date: 15.12.17

**K S R INSTITUTE FOR ENGINEERING AND TECHNOLOGY  
TIRUCHENGODE - 637 215**

**TRAINING PROGRAMME FEEDBACK FORM**



Name of the Student: GI Akilan

Branch: CSE

Year / Sem: II / IV

4. Name of the Training: Partnership

5. Name of the Trainer: Jayakumar

6. Students rating of Trainers :

S. No.	Date	Subject	Rating (√)			
			Excellent	Very good	Good	Average
1	15.12.17	Maths	✓			

4. Two positive points about the programme: 1. learnt many business tricks  
2. Full interactive class

5. Suggestions for improvement:

None

PRINCIPAL,  
K. S. R. INSTITUTE FOR  
ENGINEERING AND TECHNOLOGY,  
K. S. R. KALVI NAGAR,  
TIRUCHENGODE - 637 215,  
NAMAKKAL Dt, TAMIL NADU.

GI Akilan  
Signature

Date: 15.12.17

**K S R INSTITUTE FOR ENGINEERING AND TECHNOLOGY  
TIRUCHENGODE - 637 215**

**TRAINING PROGRAMME FEEDBACK FORM**



Name of the Student: NITHIVASRI R

Branch: B.E / EEE

Year / Sem: II / IV

1. Name of the Training : APTITUDE

2. Name of the Trainer : J. Lalitha

3. Students rating of Trainers :

S. No.	Date	Subject	Rating (√)			
			Excellent	Very good	Good	Average
1	15/12/17	APTITUDE			✓	

4. Two positive points about the programme:

*we feel that it is very useful for future exams*

5. Suggestions for improvement:

*can be little more interesting*

Date: 15/12/17

R. N. Nagar  
Signature

**K S R INSTITUTE FOR ENGINEERING AND TECHNOLOGY  
TIRUCHENGODE - 637 215**

**TRAINING PROGRAMME FEEDBACK FORM**



Name of the Student: PRIYADHARSHNI P

Branch: B.E / ECE

Year / Sem: II / IV

4. Name of the Training : APTITUDE

5. Name of the Trainer : J. Lalitha

6. Students rating of Trainers :

S. No.	Date	Subject	Rating (√)			
			Excellent	Very good	Good	Average
1	15/12/17	APTITUDE			✓	

4. Two positive points about the programme:

*We are interested, it is used to competitive exams.*

5. Suggestions for improvement:

*we need more examples.*

Date: 15/12/17

  
**P. Priyadharsini**  
 PRINCIPAL,  
 K. S. R. INSTITUTE FOR  
 ENGINEERING AND TECHNOLOGY,  
 K. S. R. KALVI NAGAR,  
 TIRUCHENGODE - 637 215,  
 NAMAKKAL Dt, TAMIL NADU.

**K S R INSTITUTE FOR ENGINEERING AND TECHNOLOGY  
TIRUCHENGODE - 637 215**

**TRAINING PROGRAMME FEEDBACK FORM**



Name of the Student: B. SWETHA

Branch: CSE

Year / Sem: II / IV

1. Name of the Training : APTITUDE

2. Name of the Trainer : Sivakumar

3. Students rating of Trainers :

S. No.	Date	Subject	Rating (✓)			
			Excellent	Very good	Good	Average
1	15/12/17	APTITUDE			✓	

4. Two positive points about the programme:

It is useful.

5. Suggestions for improvement:

Lesson should be taken slowly.

Date: 15/12/17

Signature

B. Swetha

**K S R INSTITUTE FOR ENGINEERING AND TECHNOLOGY  
TIRUCHENGODE - 637 215**

**TRAINING PROGRAMME FEEDBACK FORM**



Name of the Student: Vivek - V

Branch: B (EEE)

Year / Sem: II / IV

4. Name of the Training : Sivakumar Aptitude

5. Name of the Trainer : Sivakumar

6. Students rating of Trainers :

S. No.	Date	Subject	Rating (✓)			
			Excellent	Very good	Good	Average
1	15/12/17	aptitude			✓	

4. Two positive points about the programme:

Teaching was good  
problems practice was good

5. Suggestions for improvement:

One topic must be practiced  
with principals

Date: 15/12/17

**K. S. R. INSTITUTE FOR  
ENGINEERING AND TECHNOLOGY  
K. S. R. KALVI NAGAR,  
TIRUCHENGODE - 637 215,  
NAMAKKAL Dt, TAMIL NADU.**

Signature

Vivek - V



Name of the Student: R. Harini

Branch: BT-CSE

Year / Sem: II / 04

1. Name of the Training : Self Introduction

2. Name of the Trainer : Mr. Madhan

3. Students rating of Trainers :

S. No.	Date	Subject	Rating (✓)			
			Excellent	Very good	Good	Average
1	16.02.17	english		✓		

4. Two positive points about the programme:

stage fear overcoming

5. Suggestions for improvement:

Date: 16.02.17

R. Harini  
Signature



Name of the Student: S. Sridakshya

Branch: BT/CSE

Year / Sem: II / 04

4. Name of the Training : Respsion

5. Name of the Trainer : Mr. Mohan

6. Students rating of Trainers :

S. No.	Date	Subject	Rating (✓)			
			Excellent	Very good	Good	Average
1	16.02.17	english		✓		

4. Two positive points about the programme:

Help to revise all the topics

5. Suggestions for improvement:

Date: 16.02.17

**PRINCIPAL,**  
**K. S. R. INSTITUTE FOR**  
**ENGINEERING AND TECHNOLOGY,**  
**K. S. R. KALVI NAGAR,**  
**TIRUCHENGODE - 637 215,**  
**NAMAKKAL Dt, TAMIL NADU.**

S. Sridakshya  
Signature



Name of the Student: V. YUVAPRIYANKA.

Branch: B.E/CSE

Year / Sem: II / IV

1. Name of the Training: PLACEMENT TRAINING.

2. Name of the Trainer: SURESH

3. Students rating of Trainers :

S. No.	Date	Subject	Rating (✓)			
			Excellent	Very good	Good	Average
1	16.12.17	APTITUDE	✓			

4. Two positive points about the programme:

\* It is very useful for us for competitive exams.

5. Suggestions for improvement:

\* Nothing.

Date: 16.12.17

V. YUVAPRIYANKA  
Signature



Name of the Student: D. GOWRI

Branch: B.Tech/IT

Year / Sem: II / IV

4. Name of the Training: Placement training.

5. Name of the Trainer: Suresh

6. Students rating of Trainers :

S. No.	Date	Subject	Rating (✓)			
			Excellent	Very good	Good	Average
1	16.12.17	Aptitude		✓		

4. Two positive points about the programme:

\* Topics are taught clearly & understandable.

5. Suggestions for improvement:

Date: 16.12.17

PRINCIPAL,  
K. S. R. INSTITUTE FOR  
ENGINEERING AND TECHNOLOGY,  
K. S. R. KALVI NAGAR,  
TIRUCHENGODE - 637 215,  
NAMAKKAL Dt, TAMIL NADU.

[Signature]  
Signature

Company Specific Training Schedule [2017 - 2018] Odd Semester

Ref: KSRIET/T&P/CIR/2018-19

Date: 08.10.2017

This is to inform that all the HoD's, Faculty and CSE, ECE, EEE & IT Department Training and Placement coordinator that the Three Days External Training Programme from 11.10.2017 to 13.10.2017 for IV Year Capgemini Eligible Students for the academic year 2018 - 2019 (Odd Sem) by Six Phrase has been scheduled. All the registered students should attend the Training Programme without fail. If any student skips this Training Programme without proper permission from the respective HoDs, he / she will not be permitted for any further Training Programme and campus recruitment process. Proper Dress Code is mandatory.

Date	Branch & count
11.10.2017 To 13.10.2017	CSE - 5, IT - 6, ECE - 23 & EEE - 19  TOTAL - 53

  
T&P OFFICER

  
T&P COORDINATOR

  
PRINCIPAL

Copy to:

1. All HoDs
2. Notice Board

Session Timings:

Forenoon Session: 09.00 am to 12.30 pm    Break: 10.45 am to 11.00 am & 03.00 pm to 03.10 pm

Afternoon Session: 01.30 pm to 04.30 pm    Lunch: 12.30 pm to 01.30 pm

Evening Discussion: 05:00pm to 07:00 pm

  
PRINCIPAL  
K. S. R. INSTITUTE FOR  
ENGINEERING AND TECHNOLOGY,  
K. S. R. KALVI NAGAR,  
TIRUCHENGODE - 637 215,  
NAMAKKAL DISTRICT, TAMIL NADU.



K S R INSTITUTE FOR ENGINEERING AND TECHNOLOGY, TIRUCHENGODE - 637215

Training and Placement Cell

SIX PHRASE TRAINING PROGRAMME FOR CAPGEMINI

BATCH : 2014 - 2018

Academic Year: 2017 - 2018

Year / Sem: IV / VII

Staff Incharge:

S. No	Name	Branch	11/10/17				12/10/17				13/10/17			
			FN	FN	AN	AN	FN	FN	AN	AN	FN	FN	AN	AN
1	CHINDHAMANI RAMANATHAN	CSE	/	/	/	/	/	/	/	/	/	/	/	/
2	JENITHA KULANDAIVEL	CSE	/	/	/	/	/	/	/	/	a	a	a	a
3	KEERTHANA DURAISAMY	CSE	/	/	/	/	/	/	/	/	/	/	/	/
4	MADHUBALAN THIRUVENGADAM	CSE	/	/	/	/	/	/	/	/	/	/	/	/
5	SELVAGANAPATHI RAVICHANDRAN	CSE	/	/	/	/	a	a	a	a	/	/	/	/
6	ILAKKIYA SENGODAN	IT	/	/	/	/	/	/	/	/	/	/	/	/
7	MEPHYMONY MONIE	IT	/	/	/	/	/	/	/	/	/	/	/	/
8	NANTHAKUMAR SEKAR	IT	/	/	/	/	/	/	/	/	P	P	P	P
9	PAVITHRA SAKTHIVEL	IT	/	/	/	/	/	/	/	/	/	/	/	/
10	PRAKASH ANNADURAI	IT	/	/	/	/	a	a	a	a	/	/	/	/
11	SOWNTHIRYA MUTHUSAMY	IT	/	/	/	/	/	/	/	/	/	/	/	/
12	ANITHA MANI	EEE	/	/	/	/	/	/	/	/	/	/	/	/
13	BAWADHARANI SENTAMIL SELVAN	EEE	/	/	/	/	/	/	/	/	/	/	/	/
14	BOOPATHIRAJAN SENTHIL KUMAR	EEE	/	/	/	/	/	/	/	/	/	/	/	/
15	DIVYABHARATHI SENTHIL KUMAR	EEE	/	/	/	/	/	/	/	/	/	/	/	/
16	DIYANA SEKAR	EEE	/	/	/	/	/	/	/	/	/	/	/	/
17	GOMATHI PERIYASAMY.	EEE	/	/	/	/	/	/	/	/	/	/	/	/
18	HARINI KATHIRVEL	EEE	/	/	/	/	/	/	/	/	/	/	/	/
19	KANAGA PRIYA RAVI	EEE	/	/	/	/	/	/	/	/	/	/	/	/
20	KARTHICK BHARATHI	EEE	/	/	/	/	a	a	a	a	/	/	/	/
21	KARTHIGA NAGARAJAN	EEE	/	/	/	/	/	/	/	/	/	/	/	/
22	KARTHIK MURUGESAN	EEE	/	/	/	/	/	/	/	/	/	/	/	/
23	KAVIN KUMAR MURUGESAN	EEE	/	/	/	/	/	/	/	/	/	/	/	/
24	KEERTHANA ARUMUGA	EEE	/	/	/	/	/	/	/	/	/	/	/	/
25	KESAVAN RAJU	EEE	/	/	/	/	/	/	/	/	/	/	/	/
26	LAVANYA GANESAN	EEE	/	/	/	/	/	/	/	/	/	/	/	/
27	JEEVA VAITHILINGAM	EEE	/	/	/	/	/	/	/	/	/	/	/	/
28	KEERTHANA SADHASEKARAN	EEE	/	/	/	/	/	/	/	/	/	/	/	/
29	RAJ KUMAR GANESAN	EEE	/	/	/	/	/	/	/	/	/	/	/	/
30	NANDHINITHANGAVEL	EEE	/	/	/	/	/	/	/	/	/	/	/	/
31	RANJITH THANGAVELU	EEE	/	/	/	/	P	P	P	P	/	/	/	/
32	ROKESH KUMAR RAMESH	EEE	/	/	/	/	/	/	/	/	/	/	/	/

PRINCIPAL,  
K. S. R. INSTITUTE FOR  
ENGINEERING AND TECHNOLOGY,  
K. S. R. KALVI NAGAR,  
TIRUCHENGODE - 637 215,  
NAMAKKAL Dt., TAMIL NADU.

33	SANGAVI KALAIKUMAR	EEE	/	/	/	/	/	/	/	/	/	/	/	/
34	VIJAY RAJENDRAN	EEE	/	/	/	/	/	/	/	/	/	/	/	/
35	ARTHI KEMPUVEERAN	ECE	/	/	/	/	/	/	/	/	/	/	/	/
36	DHIVYA PRABHA PALANISAMY	ECE	/	/	/	/	/	/	/	/	/	/	/	/
37	DIVYA SENTHIL MURUGAN	ECE	/	/	/	/	/	/	/	/	/	/	/	/
38	JANANI THIRUGNANAM	ECE	/	/	/	/	/	/	/	/	/	/	/	/
39	KALAIPRIYA NAGARAJAN	ECE	/	/	/	/	/	/	/	/	/	/	/	/
40	KEERTHANA SHANMUGASUNDARAM	ECE	/	/	/	/	/	/	/	/	/	/	/	/
41	KOWSALYA MOORTHY	ECE	/	/	/	/	/	/	/	/	/	/	/	/
42	SANKARI MANOKARAN	ECE	/	/	/	/	/	/	/	/	/	/	/	/
43	SIVA RANJANI PALANICHAMY	ECE	/	/	/	/	/	/	/	/	/	/	/	/
44	SUBATHRA SARVESWARAN	ECE	/	/	/	/	/	/	/	/	/	/	/	/
45	DEEPAN KARTHIKEYAN	ECE	/	/	/	/	/	/	/	/	/	/	/	/
46	LOGANATHAN CHELLAPPAN	ECE	/	/	/	/	/	/	/	/	/	/	/	/
47	JAYASHREE SEKAR	ECE	/	/	/	/	/	/	/	/	/	/	/	/
48	KARTHIKA SUBRAMANI	ECE	/	/	/	/	/	/	/	/	/	/	/	/
49	ADHESHWARANNANDHINI M	ECE	/	/	/	/	/	/	/	/	/	/	/	/
50	POONGODI SEKAR	ECE	/	/	/	/	/	/	/	/	/	/	/	/
51	SANGEETHA NATESAN	ECE	/	/	/	/	/	/	/	/	/	/	/	/
52	VINOTHINI PERIYASAMY	ECE	/	/	/	/	/	/	/	/	/	/	/	/
53	DINESH THANGAVEL	ECE	/	/	/	/	/	/	/	/	/	/	/	/
PRESENT			52	52	51	52	46	46	46	46	47	47	47	47
ABSENT			-	-	-	-	3	3	3	3	5	5	5	5
PERMISSION			1	1	1	1	4	4	4	4	1	1	1	1
TOTAL			53	53	53	53	53	53	53	53	53	53	53	53

PRINCIPAL,  
 K. S. R. INSTITUTE FOR  
 ENGINEERING AND TECHNOLOGY,  
 K. S. R. HALL,  
 TRICHENGOLOUR - 615,  
 KARNATAKA DISTRICT, INDIA.

BATCH: 2014 - 2018

ACADEMIC YEAR: 2017 - 2018 (ODD)

DATE: 11.10.2017

Fore Noon session

S.NO	BRANCH	STRENGTH	PRESENT	ABSENT	LEAVE
1	CSE	5	5	0	0
2	ECE - A & B	23	22	0	1
3	EEE - A & B	19	19	0	0
4	IT	6	6	0	0
<b>Total</b>		<b>53</b>	<b>52</b>	<b>0</b>	<b>1</b>

After Noon Session

S.NO	BRANCH	STRENGTH	PRESENT	ABSENT	LEAVE
1	CSE	5	5	0	0
2	ECE - A & B	23	22	0	1
3	EEE - A & B	19	19	0	0
4	IT	6	6	0	0
<b>Total</b>		<b>53</b>	<b>52</b>	<b>0</b>	<b>1</b>

*[Signature]*  
T & P OFFICER

*[Signature]*  
T & P COORDINATOR

*[Signature]*  
PRINCIPAL

*[Green Checkmark]*  
PRINCIPAL,  
K. S. R. INSTITUTE FOR  
ENGINEERING AND TECHNOLOGY,  
K. S. R. KALVI NAGAR,  
TIRUCHENGODE - 637 215,  
NAMAKKAL Dt, TAMIL NADU.

BATCH: 2014 - 2018

ACADEMIC YEAR: 2017 - 2018 (ODD)

DATE: 12.10.2017

## Fore Noon session

S.NO	BRANCH	STRENGTH	PRESENT	ABSENT	LEAVE
1	CSE	5	4	0	1
2	ECE - A & B	23	20	1	2
3	EEE - A & B	19	17	1	1
4	IT	6	5	1	0
<b>Total</b>		<b>53</b>	<b>46</b>	<b>3</b>	<b>4</b>

## After Noon Session

S.NO	BRANCH	STRENGTH	PRESENT	ABSENT	LEAVE
1	CSE	5	4	0	1
2	ECE - A & B	23	20	1	2
3	EEE - A & B	19	17	1	1
4	IT	6	5	1	0
<b>Total</b>		<b>53</b>	<b>46</b>	<b>3</b>	<b>4</b>

*[Signature]*  
T & OFFICER  
12/10

*[Signature]*  
T & P COORDINATOR  
12/10/17

*[Signature]*  
12/10/17  
PRINCIPAL

*[Signature]*  
PRINCIPAL,  
K. S. R. INSTITUTE FOR  
ENGINEERING AND TECHNOLOGY,  
K. S. R. KALVI NAGAR,  
TIRUCHENGODE - 637 215,  
NAMAKKAL Dt, TAMIL NADU.

BATCH: 2014 - 2018

ACADEMIC YEAR: 2017 - 2018 (ODD)

DATE: 13.10.2017

## Fore Noon session

S.NO	BRANCH	STRENGTH	PRESENT	ABSENT	LEAVE
1	CSE	5	4	1	0
2	ECE - A & B	23	20	3	0
3	EEE - A & B	19	18	1	0
4	IT	6	5	0	1
<b>Total</b>		<b>53</b>	<b>47</b>	<b>5</b>	<b>1</b>

## After Noon Session

S.NO	BRANCH	STRENGTH	PRESENT	ABSENT	LEAVE
1	CSE	5	4	1	0
2	ECE - A & B	23	20	3	0
3	EEE - A & B	19	18	1	0
4	IT	6	5	0	1
<b>Total</b>		<b>53</b>	<b>47</b>	<b>5</b>	<b>1</b>

*[Signature]*  
T & P OFFICER  
13/10/17

*[Signature]*  
T & P COORDINATOR  
13/10/17

*[Signature]*  
PRINCIPAL  
13/10/17

*[Signature]*  
PRINCIPAL,  
K. S. R. INSTITUTE FOR  
ENGINEERING AND TECHNOLOGY,  
E. S. R. KALDI NAGAR,  
TIRUCHENGODE - 637 215,  
NAMAKKAL DG, TAMIL NADU.

K S R INSTITUTE FOR ENGINEERING AND TECHNOLOGY  
TIRUCHENGODE - 637 215

TRAINING PROGRAMME FEEDBACK FORM



Name of the Student: PAVITHRA .S

Branch: B.Tech - IT

Year / Sem: IV / VII

1. Name of the Training: SIXPHARSE

2. Name of the Trainer: Krishna

3. Students rating of Trainers :

S. No.	Date	Subject	Rating (✓)			
			Excellent	Very good	Good	Average
1	11.10.17	Verbal (Essay Writing)	✓			

4. Two positive points about the programme:

1) Able to gain more information about essay

5. Suggestions for improvement:

S. Pavithra

Signature

Date: 11.10.17

K S R INSTITUTE FOR ENGINEERING AND TECHNOLOGY  
TIRUCHENGODE - 637 215

TRAINING PROGRAMME FEEDBACK FORM



Name of the Student: KESAVAN . R

Branch: EEE

Year / Sem: IV / VII

4. Name of the Training: Logical Reasoning

5. Name of the Trainer: Santhosh

6. Students rating of Trainers :

S. No.	Date	Subject	Rating (✓)			
			Excellent	Very good	Good	Average
1	11.10.17	Logical	✓			

Capgemini video questions

4. Two positive points about the programme:

Friendly and clarity in the topic.

5. Suggestions for improvement:

No comments

Date: 11.10.17

PRINCIPAL  
K. S. R. INSTITUTE FOR  
ENGINEERING AND TECHNOLOGY,  
K. S. R. KALVI NAGAR  
TIRUCHENGODE - 637 215,  
NAMAKKAL DISTRICT, TAMIL NADU.  
R. Kesavan  
Signature

K S R INSTITUTE FOR ENGINEERING AND TECHNOLOGY  
TIRUCHENGODE - 637 215



TRAINING PROGRAMME FEEDBACK FORM

Name of the Student: R. KANAGA PRIYA

Branch: EEE

Year / Sem: IV / VII

1. Name of the Training: TECHNICAL

2. Name of the Trainer: LAKSHMI PRIYA

3. Students rating of Trainers :

S. No.	Date	Subject	Rating (✓)			
			Excellent	Very good	Good	Average
1	12.10.17	C PROGRAMMING	✓			

4. Two positive points about the programme:

Able to know the algorithms clearly.

5. Suggestions for improvement:

Date: 12.10.17

*R. Kanaga Priya*  
Signature

K S R INSTITUTE FOR ENGINEERING AND TECHNOLOGY  
TIRUCHENGODE - 637 215



TRAINING PROGRAMME FEEDBACK FORM

Name of the Student: V. Jeeva

Branch: EEE

Year / Sem: IV / VII

4. Name of the Training: Technical

5. Name of the Trainer: Lakshmi Priya

6. Students rating of Trainers : (9/10)

S. No.	Date	Subject	Rating (✓)			
			Excellent	Very good	Good	Average
1	12.10.17	C program	✓			

4. Two positive points about the programme:

She's Explain Very Clearly So easy to understand.  
- Concepts

5. Suggestions for improvement: -

Date: 12.10.17

PRINCIPAL,  
K. S. R. INSTITUTE FOR  
ENGINEERING AND TECHNOLOGY,  
K. S. R. KANYAKURUMI NAGAR,  
TIRUCHENGODE - 637 215,  
NARAYANAPURAM, TAMIL NADU.

*V. Jeeva*  
Signature

K S R INSTITUTE FOR ENGINEERING AND TECHNOLOGY  
TIRUCHENGODE - 637 215

TRAINING PROGRAMME FEEDBACK FORM



Name of the Student: K. Sangavi

Branch: EEE

Year / Sem: 2017 / 07

1. Name of the Training : Pseudocode

2. Name of the Trainer : Laxshmi Priya

3. Students rating of Trainers :

S. No.	Date	Subject	Rating (√)			
			Excellent	Very good	Good	Average
1	12.10.17	Pseudocode		✓		

4. Two positive points about the programme:

1. Clear Explanation

2. What she told we can understand

5. Suggestions for improvement:

Date: 12.10.17

K. Sangavi  
Signature

PRINCIPAL,  
K. S. R. INSTITUTE FOR  
ENGINEERING AND TECHNOLOGY,  
K. S. R. KALVI NAGAR,  
TIRUCHENGODE - 637 215,  
NAMAKKAL DI, TAMIL NADU.



K S R INSTITUTE FOR ENGINEERING AND TECHNOLOGY  
TIRUCHENGODE - 637 215



TRAINING PROGRAMME FEEDBACK FORM

Name of the Student: A. Keethana

Branch: EEE

Year / Sem: V / 1

1. Name of the Training: Quants

2. Name of the Trainer: Karthick

3. Students rating of Trainers :

S. No.	Date	Subject	Rating (✓)			
			Excellent	Very good	Good	Average
1	13/10/2017	Quants		✓		

4. Two positive points about the programme:

understanding ability  
doubt clearing.

5. Suggestions for improvement:

Date: 13/10/2017

Signature A. Keethana

K S R INSTITUTE FOR ENGINEERING AND TECHNOLOGY  
TIRUCHENGODE - 637 215



TRAINING PROGRAMME FEEDBACK FORM

Name of the Student: T. Nandhini

Branch: EEE

Year / Sem: V / VI

4. Name of the Training: Quants

5. Name of the Trainer: Karthick

6. Students rating of Trainers :

S. No.	Date	Subject	Rating (✓)			
			Excellent	Very good	Good	Average
1	13/10/17	Quants		✓		

4. Two positive points about the programme:

easily to  
slowed.

understand, shortcuts are more and problems are

5. Suggestions for improvement:

Date: 13/10/17

PRINCIPAL,  
K. S. R. INSTITUTE FOR  
ENGINEERING AND TECHNOLOGY,  
K. S. R. KALMI NAGAR,  
TIRUCHENGODE - 637 215,  
NAMAKAL DR, TAMIL NADU.

Signature

T. Nandhini



This is to inform all the HoDs and department Training and Placement coordinators that the Training Programmes on Quantitative Aptitude Training Programme for IV year students for the academic year 2017 - 2018 have been scheduled from 12.09.2017 to 13.09.2017. All the registered students should attend the Training Programme. If any student skips this Training Programme without proper permission from the respective HoDs, he / she will not be permitted for any further Training Programme and campus recruitment process. Proper Dress Code is mandatory.

**Session Timings:**

Forenoon Session: 09:15am - 12:30 pm

Afternoon Session: 01:30pm - 04:15 pm

Break: 10.45 am to 11.00 am

Lunch: 12.30 pm to 01.30 pm

  
T&P OFFICER

  
T&P COORDINATOR

  
PRINCIPAL

**Copy to:**

1. All HoDs
2. Notice Board

  
PRINCIPAL  
K. S. R. INSTITUTE FOR  
ENGINEERING AND TECHNOLOGY  
K. S. R. INSTITUTE FOR  
TRAINING AND PLACEMENT  
TIRUCHENGODE

Training and Placement Cell

SIX PHRASE TRAINING PROGRAMME - BATCH 1

BATCH : 2014 - 2018

Academic Year: 2017 - 2018

Year / Sem: IV / VII

Staff Incharge:

S. No	Reg No	Name	Branch	12/9/17		10/9		13/9			
				FN	PN	AN	FN	PN	AN	FN	PN
1	731614104005	CHINDHAMANI R M	CSE	/	/	/	/	/	/	/	/
2	731614104006	CHITHRADEVI G	CSE	/	/	/	/	/	/	/	/
3	731614104014	JEEVITHA R	CSE	/	a	P	/	/	/	/	/
4	731614104018	KEERTHANA D	CSE	/	/	/	/	/	/	/	/
5	731614104026	POORNIMA M	CSE	/	/	/	/	/	/	/	/
6	731614104027	PRIYANKA N	CSE	/	/	/	/	/	/	/	/
7	731614104301	DHARANI R	CSE	/	/	/	/	/	/	/	/
8	731614205004	ILAKKIYA S	IT	/	/	/	/	/	/	/	/
9	731614205006	MEPHYMONY D	IT	/	/	/	/	/	/	/	/
10	731614205007	NANTHAKUMAR S	IT	/	/	/	/	/	/	/	/
11	731614205008	PAVITHRA S	IT	/	/	/	/	/	/	/	/
12	731614205011	SOWNTHIRYA M	IT	/	/	/	/	/	/	/	/
13	731614105002	ANITHA M	EEE A	/	/	/	/	/	/	/	/
14	731614105005	BAWADHARANI S	EEE A	/	/	/	/	/	/	/	/
15	731614105006	BOOPALAN R	EEE A	/	/	/	/	/	/	/	/
16	731614105007	BOOPATHIRAJAN S	EEE A	/	/	/	/	/	/	/	/
17	731614105010	DIVYABHARATHI S	EEE A	/	/	/	/	/	/	/	/
18	731614105011	DIYANA S	EEE A	/	/	/	/	/	/	/	/
19	731614105013	GOMATHI P K	EEE A	/	/	/	/	/	/	/	/
20	731614105019	HARINI K	EEE A	/	/	/	/	/	/	/	/
21	731614105023	KANAGA PRIYA R	EEE A	/	/	/	/	/	/	/	/
22	731614105025	KARTHICK B	EEE A	/	/	/	/	/	/	/	/
23	731614105027	KARTHIK T M	EEE A	/	/	/	/	/	/	/	/
24	731614105028	KAVIN KUMAR M	EEE A	/	/	/	/	/	/	/	/
25	731614105029	KEERTHANA A	EEE A	/	/	/	/	/	/	/	/
26	731614105030	KESAVAN R	EEE A	/	/	/	/	/	/	/	/
27	731614105031	LAVANYA G	EEE A	/	/	/	/	/	/	/	/
28	731614105303	JEEVA V	EEE A	/	P	a	/	/	/	/	/
29	731614105304	KEERTHANA S	EEE A	/	/	/	/	/	/	/	/
30	731614105050	RANJITH T	EEE B	/	/	/	/	/	/	/	/
31	731614105055	SANGAVI K	EEE B	/	/	/	/	/	/	/	/
32	731614105067	THIYAGARAJAN S	EEE B	/	/	/	/	/	/	/	/
33	731614106003	ARTHI K	ECE	/	/	/	/	/	/	/	/
34	731614106008	DEEPAN KUMAR S	ECE	/	/	/	/	/	/	/	/
35	731614106010	DHIVYA PRABHA P	ECE	/	/	/	/	/	/	/	/
36	731614106011	DIVYA S	ECE	/	/	/	/	/	/	/	/
37	731614106012	DURKA DEVI S	ECE	/	/	/	/	/	/	/	/

Sl. No.	Roll No.	Name	Branch	11/11/2017				11/11/2017			
				FN	FN	AN	AN	FN	FN	AN	AN
38	73161106018	HEMAVARTHINI M	ECE	/	/	/	/	/	/	/	/
39	73161106020	JANANI T	ECE	/	/	/	/	/	/	/	/
40	731614106021	JANANI V.S	ECE	/	/	/	/	/	/	/	/
41	731614106023	JOTHIPRAKASH R	ECE	/	/	/	/	/	/	/	/
42	731614106025	KALAIPRIYA N	ECE	/	/	/	/	/	/	/	/
43	731614106030	KARTHIKA S	ECE	/	/	/	/	/	/	/	/
44	731614106034	KEERTHANA S	ECE	/	/	/	/	/	/	/	/
45	731614106035	KOWSALYA M	ECE	/	/	/	/	/	/	/	/
46	731614106039	LOKESH KUMAR V	ECE	/	/	/	/	/	/	/	/
47	731614106045	NAAGA NAVEEN	ECE	/	/	/	/	/	/	/	/
48	731614106049	OVIYA.T	ECE	/	/	/	/	/	/	/	/
49	731614106062	RAVI S	ECE	/	/	/	/	/	/	/	/
50	731614106064	SANGEETHA N	ECE	/	/	/	/	/	/	/	/
51	731614106065	SANKARI M	ECE	/	/	/	/	/	/	/	/
52	731614106074	SIVA RANJANI .P	ECE	a	P	a	/	/	/	/	/
53	731614106076	SRIDHAR T	ECE	/	/	/	/	/	/	/	/
54	731614106077	SUBATHRA S	ECE	a							
55	731614106079	SUGUMAR S	ECE	/	/	/	/	/	/	/	/
56	731614106085	VINOOTHINI P	ECE	a							
57	731614106301	DEEPAN.K	ECE	/	/	/	/	/	/	/	/
58	731614106701	VIGNESHWAR B	ECE	/	/	/	/	/	/	/	/
59	731614114085	MOHAMED YUNUS A	MECH - B	/	/	/	/	/	/	/	/
60	731614114086	MOHAN P	MECH - B	/	/	/	/	/	/	/	/
61	731614114092	NIVASAN K	MECH - B	/	/	/	/	/	/	/	/
62	731614114122	RANJITH KUMAR M	MECH - B	P	P	/	/	/	/	/	/
63	731614114132	SARAVANA MANOJ S	MECH - B	/	/	/	/	/	/	/	/
64	731614114140	SRIDHAR R	MECH - B	P	P	/	/	/	/	/	/
65	731614114142	SRINIVASAN.P	MECH - C	/	/	/	/	/	/	/	/
66	731614114144	SURESH P	MECH - C	/	/	/	/	/	/	/	/
67	731614114146	SURYA M	MECH - C	/	/	/	/	/	/	/	/
68	731614114150	TAMILSELVAN.S	MECH - C	P	P	/	/	/	/	/	/
69	731614114151	TARUN CHOUHAN S	MECH - C	/	/	/	/	/	/	/	/
70	731614114163	VIJAY S	MECH - C	/	/	/	/	/	/	/	/
71	731614114164	VINITHKUMARA	MECH - C	/	/	/	/	/	/	/	/
72	731614114303	DINESHKUMAR R	MECH - C	/	/	/	/	/	/	/	/
73	731614114701	SHANKAR RAM.R	MECH - C	/	/	/	/	/	/	/	/
PRESENT											
ABSENT											
PERMISSION											
TOTAL											

PRINCIPAL,  
K. S. R. INSTITUTE FOR  
ENGINEERING AND TECHNOLOGY,  
K. S. R. KALAHASTHUR,  
TIRUCHENGODE - 637 215,  
NANDYALUR, TAMIL NADU.

Training and Placement Cell

SIX PHRASE TRAINING PROGRAMME - BATCH 1

BATCH : 2014 - 2018

Academic Year: 2017 - 2018

Year / Sem: IV / VII

Staff Incharge:

S. No	Reg No	Name	Branch	12/9/17		10/9		13/9			
				FN	PN	AN	AN	FN	FN	AN	AN
1	731614104005	CHINDHAMANI R M	CSE	/	/	/	/	/	/	/	
2	731614104006	CHITHRADEVI G	CSE	/	/	/	/	/	/	/	
3	731614104014	JEEVITHA R	CSE	/	a	p	/	/	/	/	
4	731614104018	KEERTHANA D	CSE	/	/	/	/	/	/	/	
5	731614104026	POORNIMA M	CSE	/	/	/	/	/	/	/	
6	731614104027	PRIYANKA N	CSE	/	/	/	/	/	/	/	
7	731614104301	DHARANI R	CSE	/	/	/	/	/	/	/	
8	731614205004	ILAKKIYA S	IT	/	/	/	/	/	/	/	
9	731614205006	MEPHYMONY D	IT	/	/	/	/	/	/	/	
10	731614205007	NANTHAKUMAR S	IT	/	/	/	/	/	/	/	
11	731614205008	PAVITHRA S	IT	/	/	/	/	/	/	/	
12	731614205011	SOWNTHIRYA M	IT	/	/	/	/	/	/	/	
13	731614105002	ANITHA M	EEE A	/	/	/	/	/	/	/	
14	731614105005	BAWADHARANI S	EEE A	/	/	/	/	/	/	/	
15	731614105006	BOOPALAN R	EEE A	/	/	/	/	/	/	/	
16	731614105007	BOOPATHIRAJAN S	EEE A	/	/	/	/	/	/	/	
17	731614105010	DIVYABHARATHI S	EEE A	/	/	/	/	/	/	/	
18	731614105011	DIYANA S	EEE A	/	/	/	/	/	/	/	
19	731614105013	GOMATHI P K	EEE A	/	/	/	/	/	/	/	
20	731614105019	HARINI K	EEE A	/	/	/	/	/	/	/	
21	731614105023	KANAGA PRIYA R	EEE A	/	/	/	/	/	/	/	
22	731614105025	KARTHICK B	EEE A	/	/	/	/	/	/	/	
23	731614105027	KARTHIK T M	EEE A	/	/	/	/	/	/	/	
24	731614105028	KAVIN KUMAR M	EEE A	/	/	/	/	/	/	/	
25	731614105029	KEERTHANA A	EEE A	/	/	/	/	/	/	/	
26	731614105030	KESAVAN R	EEE A	/	/	/	/	/	/	/	
27	731614105031	LAVANYA G	EEE A	/	/	/	/	/	/	/	
28	731614105303	JEEVA V	EEE A	/	p	a	/	/	/	/	
29	731614105304	KEERTHANA S	EEE A	/	/	/	/	/	/	/	
30	731614105050	RANJITH T	EEE B	/	/	/	/	/	/	/	
31	731614105055	SANGAVI K	EEE B	/	/	/	/	/	/	/	
32	731614105067	THIYAGARAJAN S	EEE B	/	/	/	/	/	/	/	
33	731614106003	ARTHI K	ECE	/	/	/	/	/	/	/	
34	731614106008	DEEPAN KUMAR S	ECE	/	/	/	/	/	/	/	
35	731614106010	DHIVYA PRABHA P	ECE	/	/	/	/	/	/	/	
36	731614106011	DIVYA S	ECE	/	/	/	/	/	/	/	
37	731614106012	DURKA DEVI S	ECE	/	/	/	/	/	/	/	

PROF. DR. K. S. R. RAO  
 HEAD, DEPARTMENT FOR  
 ENGINEERING AND TECHNOLOGY,  
 K. J. S. SOUTH CAMPUS,  
 TIRUPATI - 517 215,  
 ANDHRA PRADESH.

Sl. No.	Roll No.	Name	Branch	11/11/2018				12/11/2018			
				FN	FN	AN	AN	FN	FN	AN	AN
38	73161106018	HEMAVARTHINI M	ECE	/	/	/	/	/	/	/	/
39	73161106020	JANANI T	ECE	/	/	/	/	/	/	/	/
40	731614106021	JANANI V.S	ECE	/	/	/	/	/	/	/	/
41	731614106023	JOTHIPRAKASH R	ECE	/	/	/	/	/	/	/	/
42	731614106025	KALAIPRIYA N	ECE	/	/	/	/	/	/	/	/
43	731614106030	KARTHIKA S	ECE	/	/	/	/	/	/	/	/
44	731614106034	KEERTHANA S	ECE	/	/	/	/	/	/	/	/
45	731614106035	KOWSALYA M	ECE	/	/	/	/	/	/	/	/
46	731614106039	LOKESH KUMAR V	ECE	/	/	/	/	/	/	/	/
47	731614106045	NAAGA NAVEEN	ECE	/	/	/	/	/	/	/	/
48	731614106049	OVIYA.T	ECE	/	/	/	/	/	/	/	/
49	731614106062	RAVI S	ECE	/	/	/	/	/	/	/	/
50	731614106064	SANGEETHA N	ECE	/	/	/	/	/	/	/	/
51	731614106065	SANKARI M	ECE	/	/	/	/	/	/	/	/
52	731614106074	SIVA RANJANI .P	ECE	a	P	a	/	/	/	/	/
53	731614106075	SRIDHAR T	ECE	/	/	/	/	/	/	/	/
54	731614106077	SUBATHRA S	ECE	a							
55	731614106079	SUGUMAR S	ECE	/	/	/	/	/	/	/	/
56	731614106085	VINOTHINI P	ECE	a							
57	731614106301	DEEPAN.K	ECE	/	/	/	/	/	/	/	/
58	731614106701	VIGNESHWAR B	ECE	/	/	/	/	/	/	/	/
59	731614114085	MOHAMED YUNUS A	MECH - B	/	/	/	/	/	/	/	/
60	731614114086	MOHAN P	MECH - B	/	/	/	/	/	/	/	/
61	731614114102	NIVASAN K	MECH - B	/	/	/	/	/	/	/	/
62	731614114122	RANJITH KUMAR M	MECH - B	P	P	/	/	/	/	/	/
63	731614114132	SARAVANA MANOJ S	MECH - B	/	/	/	/	/	/	/	/
64	731614114140	SRIDHAR R	MECH - B	P	P	/	/	/	/	/	/
65	731614114142	SRINIVASAN.P	MECH - C	/	/	/	/	/	/	/	/
66	731614114144	SURESH P	MECH - C	/	/	/	/	/	/	/	/
67	731614114146	SURYA M	MECH - C	/	/	/	/	/	/	/	/
68	731614114150	TAMILSELVANS	MECH - C	P	P	/	/	/	/	/	/
69	731614114151	TARUN CHOUHAN S	MECH - C	/	/	/	/	/	/	/	/
70	731614114163	VIJAY S	MECH - C	/	/	/	/	/	/	/	/
71	731614114164	VINITHKUMARA	MECH - C	/	/	/	/	/	/	/	/
72	731614114303	DINESHKUMAR R	MECH - C	/	late	/	/	/	/	/	/
73	731614114701	SHANKAR RAM.R	MECH - C	/	/	/	/	/	/	/	/
PRESENT											
ABSENT											
PERMISSION											
TOTAL											

  
 PRINCIPAL,  
 K. S. R. INSTITUTE FOR  
 ENGINEERING AND TECHNOLOGY,  
 K. S. R. CAMPUS,  
 THOCHERUDDI - 637 215,  
 NAMAKAL, DIST. TAMIL NADU.

BATCH: 2014 - 2018

ACADEMIC YEAR: 2017 - 2018 (ODD)

DATE: 12.09.2017

## Fore Noon session

S.NO	BRANCH	STRENGTH	PRESENT	ABSENT	LEAVE
1	CSE	7	7	0	0
2	ECE - A & B	24	23	1	0
3	EEE - A & B	20	19	1	0
4	IT	5	5	0	0
5	MECH - A,B & C	15	12	0	3
<b>Total</b>		<b>71</b>	<b>66</b>	<b>2</b>	<b>3</b>

## After Noon Session

S.NO	BRANCH	STRENGTH	PRESENT	ABSENT	LEAVE
1	CSE	7	7	0	0
2	ECE - A & B	24	23	1	0
3	EEE - A & B	20	19	1	0
4	IT	5	5	0	0
5	MECH - A,B & C	15	12	0	3
<b>Total</b>		<b>71</b>	<b>66</b>	<b>2</b>	<b>3</b>

 T & P OFFICER  
12/9/17

 T & P COORDINATOR  
12/9/17

 PRINCIPAL  
12/9/17

 PRINCIPAL  
K S R INSTITUTE FOR  
ENGINEERING AND TECHNOLOGY,  
K. S. N. KALVI NAGAR,  
TIRUCHENGODE - 637 215,  
NAMAIKAL, TN, TAMIL NADU.

BATCH: 2014 - 2018

ACADEMIC YEAR: 2017 - 2018 (ODD)

DATE: 13.09.2017

## Fore Noon session

S.NO	BRANCH	STRENGTH	PRESENT	ABSENT	LEAVE
1	CSE	7	7	0	0
2	ECE - A & B	24	24	0	0
3	EEE - A & B	20	20	0	0
4	IT	5	5	0	0
5	MECH - A,B & C	15	15	0	0
<b>Total</b>		<b>71</b>	<b>71</b>	<b>0</b>	<b>0</b>

## After Noon Session

S.NO	BRANCH	STRENGTH	PRESENT	ABSENT	LEAVE
1	CSE	7	7	0	0
2	ECE - A & B	24	24	0	0
3	EEE - A & B	20	20	0	0
4	IT	5	5	0	0
5	MECH - A,B & C	15	15	0	0
<b>Total</b>		<b>71</b>	<b>71</b>	<b>0</b>	<b>0</b>

*[Signature]*  
T & P OFFICER

*[Signature]*  
T & P COORDINATOR

*[Signature]*  
PRINCIPAL

PRINCIPAL  
K. S. R. INSTITUTE FOR  
ENGINEERING AND TECHNOLOGY,  
K. S. R. KALVI NAGAR,  
TIRUCHENGODE - 637 215,  
NAMAKKAL DI, TAMIL NADU.



K S R INSTITUTE FOR ENGINEERING AND TECHNOLOGY  
TIRUCHENGODE - 637 215

TRAINING PROGRAMME FEEDBACK FORM



Name of the Student: Lakshya S Branch: IT

Year / Sem: V / VII

1. Name of the Training: Quantitative Aptitude

2. Name of the Trainer: Baskaran, Sindhuja

3. Students rating of Trainers :

S. No.	Date	Subject	Rating (✓)			
			Excellent	Very good	Good	Average
1	12/9/17	Quanti	✓			

4. Two positive points about the programme:

Easy to learn shortcuts

5. Suggestions for improvement:

need to solve more problems

Date: 12/9/17

S. Sindhuja  
Signature

K. S. R. INSTITUTE FOR  
ENGINEERING AND TECHNOLOGY,  
K. S. R. KALU NAGAR,  
TIRUCHENGODE - 637 215,  
NAMANKAL DI, TAMIL NADU.

This is to inform all the HoDs and department Training and Placement coordinators that the Training Programmes on Quantitative Aptitude Training Programme for IV year students for the academic year 2017 - 2018 have been scheduled from 04.09.2017 to 05.09.2017. All the registered students should attend the Training Programme. If any student skips this Training Programme without proper permission from the respective HoDs, he / she will not be permitted for any further Training Programme and campus recruitment process. Proper Dress Code is mandatory.

**Session Timings:**

Forenoon Session: 09:15am - 12:30 pm

Afternoon Session: 01:30pm - 04:15 pm

Break: 10.45 am to 11.00 am

Lunch: 12.30 pm to 01.30 pm

  
T&P OFFICER

  
T&P COORDINATOR

  
PRINCIPAL

**Copy to:**

1. All HoDs
2. Notice Board

  
PRINCIPAL,  
K. S. R. INSTITUTE FOR  
ENGINEERING AND TECHNOLOGY,  
K. S. R. KALVI NAGAR,  
TIRUCHENGODE - 637 215,  
NAMAKKAL Dt, TAMIL NADU.

**Training and Placement Cell**

**SIX PHRASE TRAINING PROGRAMME - BATCH 1**

**BATCH : 2014 - 2018**

**Hall No:312**

**Academic Year: 2017 - 20**

**Year / Sem: IV / VII**

**Staff Incharge:**

S. No	Reg No	Name	Branch	04.09.2017				05.09.2017			
				FN	FN	AN	AN	FN	FN	AN	AN
1	731614104005	CHINDHAMANI R M	CSE	P	P	P	P	P	P	P	P
2	731614104006	CHITHRADEVI G	CSE	/	/	/	/	/	/	/	/
3	731614104014	JEEVITHA R	CSE	/	/	/	/	/	/	/	/
4	731614104018	KEERTHANA D	CSE	/	/	/	/	/	/	/	/
5	731614104026	POORNIMA M	CSE	/	/	/	/	/	/	/	/
6	731614104027	PRIYANKA N	CSE	/	/	/	/	/	/	/	/
7	731614104301	DHARANI R	CSE	/	/	/	/	/	/	/	/
8	731614205004	ILAKKIYA S	IT	/	/	/	/	/	/	/	/
9	731614205006	MEPHYMONY D	IT	/	/	/	/	/	/	/	/
10	731614205007	NANTHAKUMAR S	IT	/	/	/	/	/	/	/	/
11	731614205008	PAVITHRA S	IT	/	/	/	/	/	/	/	/
12	731614205011	SOWNTHIRYA M	IT	/	/	/	/	/	/	/	/
13	731614105002	ANITHA M	EEE A	/	/	/	/	/	/	/	/
14	731614105005	BAWADHARANI S	EEE A	/	/	/	/	/	/	/	/
15	731614105006	BOOPALAN R	EEE A	/	/	/	/	/	/	/	/
16	731614105007	BOOPATHIRAJAN S	EEE A	/	/	/	/	/	/	/	/
17	731614105010	DIVYABHARATHI S	EEE A	/	/	/	/	P	P	P	P
18	731614105011	DIYANA S	EEE A	/	/	/	/	/	/	/	/
19	731614105013	GOMATHI P K	EEE A	/	/	/	/	/	/	/	/
20	731614105019	HARINI K	EEE A	/	/	/	/	/	/	/	/
21	731614105023	KANAGA PRIYA R	EEE A	/	/	/	/	/	/	/	/
22	731614105025	KARTHICK B	EEE A	/	/	/	/	/	/	/	/
23	731614105027	KARTHIK T M	EEE A	/	/	/	/	/	/	/	/
24	731614105028	KAVIN KUMAR M	EEE A	/	/	/	/	/	/	/	/
25	731614105029	KEERTHANA A	EEE A	/	/	/	/	/	/	/	/
26	731614105030	KESAVAN R	EEE A	/	/	/	/	P	P	P	P
27	731614105031	LAVANYA G	EEE A	/	/	/	/	/	/	/	/
28	731614105303	JEEVA V	EEE A	/	/	/	/	/	/	/	/
29	731614105304	KEERTHANA S	EEE A	/	/	/	/	/	/	/	/
30	731614105050	RANJITH T	EEE B	/	/	/	/	/	/	/	/
31	731614105055	SANGAVI K	EEE B	/	/	/	/	/	/	/	/
32	731614105067	THIYAGARAJAN S	EEE B	/	/	/	/	/	/	/	/
33	731614106003	ARTHI K	ECE	P	P	P	P	/	/	/	/
34	731614106008	DEEPAN KUMAR S	ECE	/	/	/	/	/	/	/	/
35	731614106010	DHIVYA PRABHA P	ECE	P	P	P	P	/	/	/	/
36	731614106011	DIVYA S	ECE	/	/	/	/	/	/	/	/
37	731614106012	DURKA DEVI S	ECE	/	/	/	/	/	/	/	/

**PRINCIPAL,**  
**K. S. R. INSTITUTE FOR**  
**ENGINEERING AND TECHNOLOGY,**  
**K. S. R. KALVINAR,**  
**TRICHY - 687 215,**  
**TAMIL NADU.**

39	731614100020	JANANI T	ECE	/	/	/	/	/	/	/	/	/
40	731614100021	JANANI V.S	ECE	/	/	/	/	/	/	/	/	/
41	731614100023	JOTHIPRAKASH R	ECE	/	/	/	/	/	/	/	/	/
42	731614100025	KALAIPRIYA N	ECE	/	/	/	/	/	/	/	/	/
43	731614100030	KARTHIKA S	ECE	/	/	/	/	/	/	/	/	/
44	731614100034	KEERTHANA S	ECE	/	/	/	/	P	P	P	P	
45	731614100035	KOWSALYA M	ECE	/	/	/	/	/	/	/	/	/
46	731614100039	LOKESH KUMAR V	ECE	/	/	/	/	/	/	/	/	/
47	731614100045	NAAGA NAVEEN	ECE	/	/	/	/	/	/	/	/	/
48	731614100049	OVIYA.T	ECE	/	/	/	/	/	/	/	/	/
49	731614100062	RAVI S	ECE	/	/	/	/	/	/	/	/	/
50	731614100064	SANGEETHA N	ECE	/	/	/	/	/	/	/	/	/
51	731614100065	SANKARI M	ECE	/	/	/	/	/	/	/	/	
52	731614100074	SIVA RANJANI .P	ECE	/	/	/	/	/	/	/	/	/
53	731614100076	SRIDHAR T	ECE	/	/	/	/	/	/	/	/	/
54	731614100077	SUBATHRA S	ECE	/	/	/	/	P	P	P	P	
55	731614100079	SUGUMAR S	ECE	/	/	/	/	/	/	/	/	
56	731614100085	VINOTHINI P	ECE	/	/	/	/	/	/	/	/	/
57	731614100301	DEEPAN.K	ECE	/	/	/	/	/	/	/	/	/
58	731614100701	VIGNESHWAR B	ECE	/	/	/	/	/	/	/	/	/
59	731614114085	MOHAMED YUNUS A	MECH - B	/	/	/	/	/	/	/	/	/
60	731614114086	MOHAN P	MECH - B	/	/	/	/	P	P	P	P	
61	731614114102	NIVASAN K	MECH - B	/	/	/	/	/	/	/	/	/
62	731614114122	RANJITH KUMAR M	MECH - B	/	/	/	/	/	/	/	/	/
63	731614114132	SARAVANA MANOJ S	MECH - B	P	P	P	P	/	/	/	/	/
64	731614114140	SRIDHAR R	MECH - B	/	/	/	/	/	/	/	/	/
65	731614114142	SRINIVASAN.P	MECH - C	/	/	/	/	/	/	/	/	/
66	731614114144	SURESH P	MECH - C	/	/	/	/	/	/	/	/	/
67	731614114146	SURYA M	MECH - C	/	/	/	/	/	/	/	/	/
68	731614114150	TAMILSELVAN.S	MECH - C	/	/	/	/	/	/	/	/	/
69	731614114151	TARUN CHOUHAN S	MECH - C	/	/	/	/	/	/	/	/	/
70	731614114163	VIJAY S	MECH - C	/	/	/	/	/	/	/	/	/
71	731614114164	VINITHKUMARA	MECH - C	/	/	/	/	P	P	P	P	
72	731614114303	DINESHKUMAR R	MECH - C	/	/	/	/	/	/	/	/	/
73	731614114701	SHANKAR RAM.R	MECH - C	/	/	/	/	/	/	/	/	/
74												
75												
PRESENT				69	69	69	69	66	66	66	66	
ABSENT				-	-	-	-	-	-	-	-	
PERMISSION				04	04	04	04	07	07	07	07	
TOTAL				73	73	73	73	73	73	73	73	

PRINCIPAL,  
K. S. R. INSTITUTE FOR  
ENGINEERING AND TECHNOLOGY,  
K. S. P. KALYANAGAR,  
TRUCHENGODE - 607 315,  
NAMAKKAL DISTRICT, TAMIL NADU.

**Training and Placement Cell**

**SIX PHRASE TRAINING PROGRAMME - BATCH 2**

**BATCH : 2014 - 2018**

**Hall No:104**

**Academic Year: 2017 - 2018**

**Year / Sem: IV / VII**

**Staff Incharge:**

S. No	Reg No	Name	Branch	04.09.2017				05.09.2017			
				FN	FN	AN	AN	FN	FN	AN	AN
1	731614104002	ANGUPRAKASH V	CSE	/	/	/	/	/	/	/	/
2	731614104003	ASWIN SANKAR C	CSE	/	/	/	/	/	/	/	/
3	731614104015	JENITHA K	CSE	/	/	/	/	/	/	/	/
4	731614104019	KEERTHANA P	CSE	a	a	a	a	a	a	a	a
5	731614104021	MADHUBALAN T	CSE	/	/	/	/	/	/	/	/
6	731614104025	NIVEDITHA S	CSE	/	/	/	/	/	/	/	/
7	731614104038	THIRUMURUGAN S	CSE	/	/	/	/	/	/	/	/
8	731614104041	VIGNESHI PERUMAL R	CSE	/	/	/	/	/	/	/	/
9	731614104302	KARTHIK RAJA J	CSE	/	/	/	/	/	/	/	/
10	731614104702	ANBHUCKARASI P	CSE	/	/	/	/	/	/	/	/
11	731614205002	GODSON VINCE ALEX A	IT	/	/	/	/	/	/	/	/
12	731614205009	PRAKASH A	IT	/	/	/	/	/	/	/	/
13	731614105004	BALACHANDAR K R	EEE A	/	/	/	/	/	/	/	/
14	731614105017	HARIHARAN G	EEE A	/	/	/	/	P	P	P	P
15	731614105026	KARTHIKA N	EEE A	/	/	/	/	/	/	/	/
16	731614105310	RAJ KUMAR G K	EEE A	/	/	/	/	/	/	/	/
17	731614105039	NANDHINI T	EEE B	/	/	/	/	/	/	/	/
18	731614105040	NOORNIHARA	EEE B	/	/	/	/	P	P	P	P
19	731614105053	ROKESH KUMAR R	EEE B	/	/	/	/	/	/	/	/
20	731614105074	VINOTH KUMAR R	EEE B	/	/	/	/	/	/	/	/
21	731614105077	YUVARAJ V	EEE B	/	/	/	/	/	/	/	/
22	731614106004	ARUN S K	ECE	/	/	/	/	/	/	/	/
23	731614106009	DIHIVYA DIHARANI J	ECE	P	P	P	P	/	/	/	/
24	731614106013	ELIZABETH N J	ECE	/	/	/	/	a	a	a	a
25	731614106019	JANANI R	ECE	/	/	/	/	/	/	/	/
26	731614106022	JAYASHREE S	ECE	a	a	a	a	/	/	/	/
27	731614106024	KAAVIYA M	ECE	/	/	/	/	/	/	/	/
28	731614106036	KRISHNA M	ECE	/	/	/	/	/	/	/	/
29	731614106037	LOGANATHAN C	ECE	/	/	/	/	a	a	a	a
30	731614106044	MANOJ KUMAR K	ECE	/	/	/	/	/	/	/	/
31	731614106053	POONGODI S	ECE	/	/	/	/	/	/	/	/
32	731614106059	PRIYA R	ECE	P	P	P	P	/	/	/	/
33	731614106067	SARAVANAN R	ECE	/	/	/	/	/	/	/	/
34	731614106075	SOUNDHARYA V	ECE	/	/	/	/	/	/	/	/
35	731614106080	SURIYA V	ECE	/	/	/	/	/	/	/	/
36	731614104015	ARJUN B	MECH - A	P	P	P	P	/	/	/	/
37	731614104017	ARJUN T	MECH - A	/	/	/	/	/	/	/	/

PRINCIPAL,  
 K. S. P. INSTITUTE FOR  
 ENGINEERING AND TECHNOLOGY,  
 K. S. P. RAMI NADAR,  
 TIRUCHENGOORU - 637 216,  
 NARASIPPA DI, TAMIL NADU.

39	7	EL 4029	DEVARAJ N	MECH - A	/	/	/	/	P	P	P	P
40	7	EL 4031	DIANUSH KUMAR K	MECH - A	/	/	/	/	/	/	/	/
41	7	EL 4033	DINESH S V	MECH - A	/	/	/	/	/	/	/	/
42	7	EL 4039	GOKULPRASATH L	MECH - A	/	/	/	/	P	P	P	P
43	7	EL 4040	GORUL RAJ M	MECH - A	P	P	P	P	/	/	/	/
44	7	EL 4050	HARISH V	MECH - A	/	/	/	/	/	/	/	/
45	7	EL 4054	JAYAPRAKASH R	MECH - A	/	/	/	/	/	/	/	/
46	7	EL 4059	KARTHI S	MECH - A	/	/	/	/	/	/	/	/
47	7	EL 4060	KISHORKUMARAN S	MECH - A	/	/	/	/	/	/	/	/
48	7	EL 4092	MURHAJ R	MECH - B	/	/	/	/	/	/	/	/
49	7	EL 4134	SATHISHRAJ K	MECH - B	/	/	/	/	P	P	P	P
50	7	EL 4141	SRINATH V	MECH - B	/	/	/	/	/	/	/	/
51	7	EL 4154	VASANTH S	MECH - C	/	/	/	/	A	A	A	A
52	7	EL 4155	VELMURUGAN M	MECH - C	/	/	/	/	/	/	/	/
53	7	EL 4159	VENUGOPAL V	MECH - C	/	/	/	/	/	/	/	/
54	7	EL 4166	VJAYAKUMAR M	MECH - C	/	/	/	/	/	/	/	/
55	7	EL 4326	SURENDARA	MECH - C	/	/	/	/	/	/	/	/
PRESENT					49	49	49	49	46	46	46	46
ABSENT					2	2	2	2	4	4	4	4
PERMISSION					4	4	4	4	5	5	5	5
TOTAL					55	55	55	55	55	55	55	55

  
**PRINCIPAL,**  
**K. S. R. INSTITUTE FOR**  
**ENGINEERING AND TECHNOLOGY,**  
**K. S. R. KALAI NAGAR,**  
**TIRUCHENGODE - 617 215,**  
**NAMANGAL DE, TAMIL NADU.**

## Training and Placement Cell

## SIX PHRASE TRAINING PROGRAMME - BATCH 3

BATCH : 2014 - 2018

Hall No: MIC 102

Academic Year: 2017 - 2018

Year / Sem: IV / VII

Staff Incharge:

S. No	Reg No	Name	Branch	04/09/17				5/9			
				FN	FN	AN	AN	FN	FN	AN	AN
1	731614104007	DEEPAKFERNANDEZ M	CSE	/	/	/		/	/	/	/
2	731614104012	JAISRE A	CSE	/	/	/		/	/	/	/
3	731614104033	SARAVANA ABISHEK G	CSE	a	a	a		a	a	a	a
4	731614104037	SELVAGANAPATHI R	CSE	/	/	/		/	/	/	/
5	731614104305	PUGAL MANI P	CSE	/	/	/		/	/	/	a
6	731614104306	SABARI NATHAN S	CSE	/	/	/		/	/	/	/
7	731614105003	ARAVINDHAN B	EEE A	/	/	/		/	/	/	/
8	731614105009	DHIVAGAR A	EEE A	/	/	/		/	/	/	/
9	731614105021	HARIRAMU R	EEE A	/	/	/		/	/	/	a
10	731614105033	MATHANA GOPAL G	EEE A	/	/	/		/	/	/	a
1	731614105305	MADHAN D	EEE A	/	/	/		/	/	/	/
12	731614105312	THIRUMOORTHY G	EEE A	/	/	/		/	/	/	a
13	731614105034	MOTHINATH S	EEE B	a	/	/		/	/	/	/
14	731614105035	MOULIDHARAN S	EEE B	a	/	/		/	/	/	/
15	731614105041	PRAKASH C	EEE B	/	/	a		/	/	/	/
16	731614105042	PRAVEENKUMAR B	EEE B	/	/	/		/	/	/	/
17	731614105051	SABAREESWARAN A	EEE B	/	/	/		/	/	/	a
18	731614105057	SIVAGURU U	EEE B	/	/	/		/	/	/	a
19	731614105058	SOMA SUNDARAM R	EEE B	/	/	/		/	/	/	/
20	731614105059	SOUNDARAKUMAR C	EEE B	a	/	/		/	/	/	/
21	731614105060	STEEPHANSIBU S	EEE B	/	/	/		/	/	/	/
22	731614105062	SURYA S	EEE B	/	/	/		/	/	/	/
23	731614105068	UTHIRAKUMAR E	EEE B	/	/	/		/	/	/	/
2	731614105072	VIJAY R	EEE B	a	a	a		a	a	a	a
25	731614105073	VIJAYAN.N	EEE B	/	/	/		/	/	/	/
26	731614105076	YOKESHWARAN B	EEE B	/	/	/		/	/	/	/
27	731614114001	ABHIRAM T	MECH - A	P	P	P		P	P	P	P
28	731614114003	AJITHKUMAR M	MECH - A	/	/	/		/	/	/	/
29	731614114004	AJITHKUMAR M	MECH - A	/	/	/		/	/	/	/
30	731614114007	ANAND S	MECH - A	/	/	/		/	/	/	a
31	731614114011	ARAVINDHAN A J	MECH - A	/	/	/		/	/	/	a
32	731614114012	ARAVINDHARAJ S	MECH - A	/	/	/		/	/	/	a
33	731614114013	ARAVINTH K	MECH - A	/	/	/		/	/	/	a
34	731614114018	ARUL PRAKASH P	MECH - A	/	/	PLC		/	/	/	/
35	731614114023	BALAJI L	MECH - A	/	/	/		/	/	/	/
36	731614114024	BARATHRAJ M	MECH - A	/	/	/		/	/	/	/
37	731614114027	DEEPANCHAKRAVARTHI S	MECH - A	/	/	a		/	/	/	/
38	731614114028	DEVAN R	MECH - A	/	/	/		/	/	/	/

39	731614114030	DHANASEKARAN A	MECH - A	/	/	/	/	/	/	/
40	731614114032	DHAYANITHI R	MECH - A	/	/	/	/	/	/	a
41	731614114034	DINESHKUMAR M	MECH - A	/	/	ptc	/	/	/	/
42	731614114036	EYAD MUHAMMED	MECH - A	P	P	P	P	P	P	P
43	731614114037	GANESHKARTHIK M	MECH - A	/	/	/	/	/	/	/
44	731614114038	GOKUL KUMAR R	MECH - A	/	/	/	/	/	/	a
45	731614114041	GOWTHAM P	MECH - A	L	L	ptc	/	/	/	/
46	731614114042	GOWTHAM S	MECH - A	/	/	/	/	/	/	/
47	731614114043	GOWTHAMAN S	MECH - A	L	L	L	/	/	/	/
48	731614114046	HARIHARAN K	MECH - A	/	/	/	/	/	/	/
49	731614114047	HARIHARAN M	MECH - A	/	/	/	/	/	/	a
50	731614114048	HARIHARAN S	MECH - A	/	/	/	/	/	/	/
51	731614114049	HARIHARASUDAN S ⇒ Batch-2	MECH - A	/	/	/	/	/	/	/
52	731614114051	HARISHANKAR N	MECH - A	/	/	ptc	/	/	/	/
53	731614114052	IZAZS AHAMMED S	MECH - A	/	/	/	/	/	/	/
54	731614114055	KAMALAKANNAN V	MECH - A	/	/	ptc	/	/	/	a
55	731614114057	KARTHICK P	MECH - A	a	a	a	/	/	/	/
56	731614114061	KARTHIKEYAN S (17/06/1996)	MECH - A	L	L	L	/	/	/	/
57	731614114062	KARTHIKEYAN S (06/03/1997)	MECH - A	/	/	/	/	/	/	/
58	731614114064	KAVIYARASU B	MECH - A	L	L	L	L	L	L	L
59	731614114068	KUMARAN E	MECH - A	/	/	/	/	/	/	/
60	731614114069	LAVANYA S	MECH - A	/	/	/	/	/	/	/
61	731614114070	LAXMANAN M	MECH - A	/	/	/	/	/	/	/
62	731614114094	MUTHURAJ S	MECH - B	/	/	/	/	/	/	/
63	731614114098	NAVEEN P	MECH - B	/	/	/	a	a	a	a
64	731614114149	TAMILMANI P	MECH - C	/	/	/	a	a	a	a
65	731614114160	VIGNESH.D	MECH - C	a	a	a	/	/	/	/
66	731614114309	GOPINATH.K	MECH - C	/	/	ptc	/	/	/	/

PRESENT

ABSENT

PERMISSION

TOTAL

29 Raghu. M

CSE

PRINCIPAL,  
K. S. R. INSTITUTE FOR  
ENGINEERING AND TECHNOLOGY,  
K. S. R. KALVI NAGAR,  
TIRUCHENGODE - 637 215,  
NAMAKKAL Dt, TAMIL NADU.



## Training and Placement Cell

## SIX PHRASE TRAINING PROGRAMME - BATCH 4

BATCH : 2014 - 2018

Academic Year: 2017 - 2018

Year / Sem: IV / VII

Hall No: MIC 103

Staff Incharge:

S. No	Reg No	Name	Branch	04/09/17				05/09/17			
				FN	FN	AN	AN	FN	FN	AN	AN
1	731614205001	GNANASEKAR N	IT	a	a	a		a	a	a	
2	731614205013	VIJAY S	IT	a	a	a		a	a	a	
3	731614106001	ABINAYA R	ECE	/	/	/		/	/	/	
4	731614106002	ARAVIND K	ECE	a	a	a		a	a	a	
5	731614106006	BARATHKUMAR M	ECE	/	/	/		/	/	/	
6	731614106007	DEEPAK RAJU C	ECE	/	/	/		/	/	/	
7	731614106015	GOKUL RAJ K N	ECE	a	a	a		a	a	a	
8	731614106016	GOPIKA N	ECE	/	/	/		/	/	/	
9	731614106017	GOVINDARAJ M	ECE	/	/	/		/	/	/	
10	731614106027	KANMANI R	ECE	/	/	/		/	/	/	
11	731614106032	KATHIRESH S	ECE	/	/	/		/	/	/	/
12	731614106040	MADHU KRISHNA B	ECE	/	/	/		/	/	/	
13	731614106046	NANDHINI M	ECE	/	/	/		/	/	/	
14	731614106050	PADMAPRIYA E	ECE	/	/	/		/	/	/	
15	731614106051	PARTHASARATHI M M	ECE	/	/	/		/	/	/	
16	731614106052	PAVITHRAN S	ECE	/	/	/		/	/	/	
17	731614106054	PRADEEPA S	ECE	/	/	/		/	/	/	
18	731614106063	RAVI VARMA B	ECE	/	/	/		/	/	/	
19	731614106066	SANTHOSH E	ECE	/	/	/		/	/	/	
20	731614106070	SHARANYA A	ECE	/	/	/		/	/	/	
21	731614106082	THAMARA KANNAN S	ECE	/	/	/		/	/	/	
22	731614106302	DINESH T	ECE	/	/	/		/	/	/	
23	731614106307	RANGANATHAN S	ECE	/	/	/		/	/	/	
24	731614106311	UDHAYAKUMAR B	ECE	/	/	/		/	/	/	
25	731614114072	LOGESHKUMAR A	MECH - B	/	/	/		/	/	/	
26	731614114074	MAHENDRAN A	MECH - B	/	/	/		/	/	/	
27	731614114077	MANOJ KUMAR R	MECH - B	OD	OD	OD		OD	OD	OD	
28	731614114079	MEIPRAKASH K	MECH - B	/	/	/		/	/	/	
29	731614114080	MITHUN CHAKRAVARTHY G	MECH - B	/	/	/		a	a	a	
30	731614114083	MOHAMED RIYAZ M	MECH - B	/	/	/		P	P	P	
31	731614114084	MOHAMEDSIRAJDHEEN A.A	MECH - B	/	/	/		/	/	/	
32	731614114087	MOHAN S	MECH - B	/	/	/		/	/	/	
33	731614114088	MOHAN RAJ R	MECH - B	L	L	L		/	/	/	
34	731614114089	MUGLESHWARAN K	MECH - B	/	a	/		/	/	/	
35	731614114090	MUHILARASU S	MECH - B	/	/	/		a	a	a	
36	731614114091	MUHINTHAR S	MECH - B	/	/	/		/	/	/	
37	731614114095	NAINAR MOHAMED S	MECH - B	/	/	/		/	/	/	
38	731614114097	NARESHKUMAR B	MECH - B	/	a	/		/	/	/	

39	731614114101	NETHAJI M	MECH - B	/	/	/		/	/	/	
40	731614114106	PRADEEP N	MECH - B	/	/	/		/	/	/	
41	731614114108	PRAKASH RAJ T	MECH - B	/	/	/		/	/	/	
42	731614114110	PRASANTH C	MECH - B	/	a	/		/	/	/	
43	731614114114	RADHAKRISHNAN S	MECH - B	P	P	P		P	P	P	
44	731614114115	RAGHUL KUMAR K	MECH - B	/	/	/		/	/	/	
45	731614114116	RAJASEKAR A	MECH - B	a	a	a		a	a	a	
46	731614114121	RANJITH KUMAR C	MECH - B	/	/	/		P	P	P	
47	731614114123	RANJITH KUMAR S	MECH - B	/	/	/		/	/	/	
48	731614114124	SABAREESAN M	MECH - B	/	/	/		P	P	P	
49	731614114126	SABARIGIRI G	MECH - B	/	/	/		/	/	/	
50	731614114128	SAM PRAKASH S	MECH - B	OD	OD	OD		OD	OD	OD	
51	731614114133	SATHISH K	MECH - B	a	a	a		/	/	/	
52	731614114136	SHIVKUMAR S	MECH - B	/	/	/		P	P	P	
53	731614114139	SRIDHAR K	MECH - B	/	/	Pic		/	/	/	
54	731614114143	SUKRUTH B	MECH - C	P	P	P		P	P	P	
55	731614114152	THIRULOGA SANTHAR K	MECH - C	/	/	/		a	a	a	
56	731614114156	VENKADESH S	MECH - C	/	/	/		/	/	/	
57	731614114311	JEEVA.S	MECH - C	/	/	/		/	/	/	
58	731614114312	KAVIYARASAN S	MECH - C	/	/	/		/	/	/	
59	731614114313	LOGESH A	MECH - C	/	/	/		a	a	a	
60	731614114314	MADHAN RAJ D	MECH - C	/	/	P		a	a	a	
61	731614114315	MANJUNATH S	MECH - C	OD	OD	OD		P	P	P	
62	731614114316	MUDALIYAR VISHNU PARASUR	MECH - C	/	/	Pic		/	/	/	
63	731614114317	NAVEEN C	MECH - C	/	/	/		/	/	/	
64	731614114329	VENKATESH.P	MECH - C	OD	OD	OD		OD	OD	OD	
65	731614114331	VIVEKKUMAR G	MECH - C	/	/	/		a	a	a	
66	731614114704	ARUN S.V	MECH - C	/	/	/		late	a	a	
PRESENT											
ABSENT											
PERMISSION											
TOTAL											

  
 PRINCIPAL,  
 K. S. R. INSTITUTE FOR  
 ENGINEERING AND TECHNOLOGY,  
 K. S. R. KALAI NAGAR,  
 THIRUENKODE - 637 216,  
 NANAKMAL DI, TAMIL NADU.

BATCH: 2014 - 2018

ACADEMIC YEAR: 2017 - 2018 (ODD)

DATE: 04.09.2017

## Fore Noon session

S.NO	BRANCH	STRENGTH	PRESENT	ABSENT	LEAVE
1	CSE	23	20	2	1
2	ECE - A & B	62	55	3	4
3	EEE - A & B	49	44	4	1
4	IT	9	7	2	0
5	MECH - A,B & C	117	96	5	16
<b>Total</b>		<b>260</b>	<b>222</b>	<b>16</b>	<b>22</b>

## After Noon Session

S.NO	BRANCH	STRENGTH	PRESENT	ABSENT	LEAVE
1	CSE	23	20	2	1
2	ECE - A & B	62	55	3	4
3	EEE - A & B	49	44	4	1
4	IT	9	7	2	0
5	MECH - A,B & C	117	96	5	16
<b>Total</b>		<b>260</b>	<b>222</b>	<b>16</b>	<b>22</b>

*[Signature]*  
T & P OFFICER

*[Signature]*  
T & P COORDINATOR

*[Signature]*  
PRINCIPAL

PRINCIPAL,  
K. S. R. INSTITUTE FOR  
ENGINEERING AND TECHNOLOGY,  
K. S. R. KALVI NAGAR,  
TIRUCHENGODE - 637 215,  
NARAYANAL DI, TAMIL NADU.

BATCH: 2014 - 2018

ACADEMIC YEAR: 2017 - 2018 (ODD)

DATE: 05.09.2017

## Fore Noon session

S.NO	BRANCH	STRENGTH	PRESENT	ABSENT	LEAVE
1	CSE	23	19	2	2
2	ECE - A & B	62	58	2	2
3	EEE - A & B	49	44	1	4
4	IT	9	7	2	0
5	MECH - A,B & C	117	88	13	16
<b>Total</b>		<b>260</b>	<b>216</b>	<b>20</b>	<b>24</b>

## After Noon Session

S.NO	BRANCH	STRENGTH	PRESENT	ABSENT	LEAVE
1	CSE	23	19	2	2
2	ECE - A & B	62	58	2	2
3	EEE - A & B	49	44	1	4
4	IT	9	7	2	0
5	MECH - A,B & C	117	88	13	16
<b>Total</b>		<b>260</b>	<b>216</b>	<b>20</b>	<b>24</b>

*K. S. R. Institute*  
T & P OFFICER

*[Signature]*  
T & P COORDINATOR

*[Signature]*  
PRINCIPAL

PRINCIPAL,  
K. S. R. INSTITUTE FOR  
ENGINEERING AND TECHNOLOGY,  
K. S. R. KALVI ROAD,  
TIRUCHENGODE - 637215,  
NAMAGAL DI, TAMIL NADU.

K. S. R. INSTITUTE FOR ENGINEERING AND TECHNOLOGY  
TIRUCHENGODE - 637 215

TRAINING PROGRAMME FEEDBACK FORM



Name of the Student: A. R. ARUNKUMAR

Branch: MECHANICAL ENGINEERING

Year / Sem: IV / VII

1. Name of the Training : VERBAL APTITUDE

2. Name of the Trainer : MR. BASUKAR, SHINDU

3. Students rating of Trainers :

S. No.	Date	Subject	Rating (√)			
			Excellent	Very good	Good	Average
1	04.09.2017	VERBAL			✓	

4. Two positive points about the programme:

- \* Learned about corporate,
- \* Aptitude solving speed improvement.

5. Suggestions for improvement:

NO

Date: 04.09.2017

  
Signature

K. S. R. INSTITUTE FOR ENGINEERING AND TECHNOLOGY  
TIRUCHENGODE - 637 215

TRAINING PROGRAMME FEEDBACK FORM



Name of the Student: G. Vivek Kumar

Branch: Mech

Year / Sem: IV / VII

1. Name of the Training : ~~Simple & Compound Interest~~, Simple & Compound Interest

2. Name of the Trainer : SHARMEELA

3. Students rating of Trainers :

S. No.	Date	Subject	Rating (√)			
			Excellent	Very good	Good	Average
1	4.9.2017	Ages, sitting Arrangement		✓		

4. Two positive points about the programme:

- \* good teaching
- \* easy communication & simple English.

5. Suggestions for improvement:

Date:

PRINCIPAL,  
K. S. R. INSTITUTE FOR  
ENGINEERING AND TECHNOLOGY,  
K. S. R. KALYANAGAR,  
TIRUCHENGODE - 637 215,  
NAMAKKAL DISTRICT, TAMIL NADU.

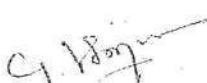
  
Signature



Name of the Student: B. ARVINDHAN

Branch: EEE

Year / Sem: Final / 07

4. Name of the Training: Verbal, Logical reasoning.

5. Name of the Trainer: Sharmila, Sindhuja, Baskaran.

6. Students rating of Trainers :

S. No.	Date	Subject	Rating (✓)			
			Excellent	Very good	Good	Average
1	4/9/17	Simple Interest Compound Interest		✓		

4. Two positive points about the programme:

Learning new words.

5. Suggestions for improvement:

How to approach a person.

Brief explanation needed.

Date: 4/9/17

B. Arvindhan  
Signature



Name of the Student: A. Noornihar

Branch: EEE

Year / Sem:

1. Name of the Training: Verbal

2. Name of the Trainer: Mr. Baskaran.

3. Students rating of Trainers :

S. No.	Date	Subject	Rating (✓)			
			Excellent	Very good	Good	Average
1	4-9-2017			✓	✓	

4. Two positive points about the programme: \*Information about corporate IT companies \* correction in self introduction.

5. Suggestions for improvement:

Need to teach related topics.

Date: 4-9-2017

PRINCIPAL,  
K. S. R. INSTITUTE FOR  
ENGINEERING AND TECHNOLOGY,  
TIRUCHENGODE.  
A. Noornihar

FN

TRAINING PROGRAMME FEEDBACK FORM

Name of the Student: C. Soundaraskumar

Branch: EEE 'B'

Year / Sem: IV / VII

4. Name of the Training: Verbal

5. Name of the Trainer: Ms. S. Hanumanthamma Sindhu

6. Students rating of Trainers :

S. No.	Date	Subject	Rating (√)			
			Excellent	Very good	Good	Average
1	05/09/17 (FN)	Quantis, Reason Verbal			✓	

4. Two positive points about the programme:

- \* her approaching of explanation method was Good
- \* how she clarified doubts are individual basis.

5. Suggestions for improvement:

- \* Improve her speed of explanation

Date: 05/09/17 (FN)

Signature

*C. Soundaraskumar*

AN

TRAINING PROGRAMME FEEDBACK FORM

Name of the Student: S. KARTHIKEYAN

Branch: MECH 'A'

Year / Sem: IV / VII

1. Name of the Training: Verbal

2. Name of the Trainer: Wilson

3. Students rating of Trainers : As per

S. No.	Date	Subject	Rating (√)			
			Excellent	Very good	Good	Average
1	05/09/17	odd man out, para formation			✓	

4. Two positive points about the programme:

- \* Interaction of the trainer was excellent
- \* Doud clarified easily.

5. Suggestions for improvement:

- \* Improve his clarity of speech

Date: 05/09/17 (AN)

Signature

*Wilson*

Ref: KSRIET/T&P/CIR/2017-18

Date: 25.08.2017

This is to inform that all the HoDs and department Training and Placement coordinators that the Four days (31.08.2017 to 03.09.2017) Aptitude Training Programme for IV year Wipro Eligible PRP students (CSE, ECE, EEE & IT) by Six Phrase during the academic year 2017 - 2018 (Odd Sem) has been scheduled as given below. All the registered students should attend the Training Programme without fail. If any student skips this Training Programme without proper permission from the respective HoDs, he / she will not be permitted for any further Training Programme and campus recruitment process. Proper Dress Code is mandatory.

Date	Branch & Count
31.08.2017 to 03.09.2017	CSE - 17, IT - 7, EEE A - 19, EEE B - 4, ECE - 27  Total - 74

**TIMINGS:**

FORENOON SESSION:

09:00 - 12:30 (Break - 10:45 - 11:00)

AFTERNOON SESSION:

01:30 - 04:15 (Break - 02:30 - 02:45)

  
T&P OFFICER

  
T&P COORDINATOR

  
PRINCIPAL

Copy to:

1. All HoDs
2. Notice Board

  
PRINCIPAL,  
K. S. R. INSTITUTE FOR  
ENGINEERING AND TECHNOLOGY,  
K. S. R. KALPALADAR,  
TIRUCHENGODE - 637 215,  
NARAKKALUR, TAMIL NADU



S.No.	Reg No.	Name	Dept	31/8/17		11/9/17		21/9/17		31/9/17	
				FN	AN	FN	AN	FN	AN	FN	AN
1	731614104002	ANGUPRAKASH V	CSE	/	/	X	/	X	X	/	/
2	731614104003	ASWIN SANKAR C Z	CSE	/	/	X	/	X	X	a	a
3	731614104005	CHINDHAMANI R M	CSE	/	/	a	a	X	X	/	/
4	731614104006	CHITHRADEVI G	CSE	/	/	X	/	X	X	a	a
5	731614104014	JEEVITHA R	CSE	/	P	P	P	P	P	/	/
6	731614104015	JENITHA K	CSE	/	/	X	/	X	X	/	/
7	731614104018	KEERTHANA D	CSE	/	/	X	/	X	X	P	P
8	731614104019	KEERTHANA P .	CSE	/	/	X	/	a	a	a	a
9	731614104021	MADHUBALAN T	CSE	/	/	X	X	X	X	a	a
10	731614104025	NIVEDITHA S	CSE	a	a	X	/	a	a	a	a
11	731614104026	POORNIMA M Z	CSE	/	/	X	/	X	X	a	a
12	731614104027	PRIYANKA N	CSE	/	/	X	/	X	X	a	a
13	731614104038	THIRUMURUGAN S	CSE	/	/	X	X	X	X	P	/
14	731614104041	VIGNESH PERUMAL R Z	CSE	/	/	X	/	X	X	a	a
15	731614104301	DHARANI R	CSE	a	a	a	a	X	X	/	/
16	731614104302	KARTHIK RAJA J	CSE	/	/	X	/	X	X	/	/
17	731614104702	ANBHUCKARASI P	CSE	/	/	a	a	a	a	a	a
18	731614205002	GODSON VINCE ALEX A Z	IT	P	.	X	X	X	X	a	a
19	731614205004	ILAKKIYA S Z	IT	P	/	X	/	P	P	P	P
20	731614205006	MEPHYMONY D	IT	P		X	/	X	X	P	P
21	731614205007	NANTHAKUMAR S Z	IT	P		X	/	X	X	P	P
22	731614205008	PAVITHRA S	IT	P		X	/	X	X	/	/
23	731614205009	PRAKASH A	IT	P		X	X	X	X	/	a
24	731614205011	SOWNTHIRYA M Z	IT	P		X	/	X	X	/	/
25	731614105002	ANITHA M	EEE A	/	/	X	a	X	X	/	/
26	731614105005	BAWADHARANI S	EEE A	/	/	X	/	X	X	/	/
27	731614105006	BOOPALAN R Z	EEE A	/	/	X	/	X	X	/	/
28	731614105007	BOOPATHIRAJAN S	EEE A	/	/	X	/	X	X	a	a
29	731614105010	DIVYABHARATHI S	EEE A	/	/	X	a	X	X	/	/
30	731614105011	DIYANA S	EEE A	/	/	X	a	X	X	/	/
31	731614105013	GOMATHI P K	EEE A	/	/	X	/	X	X	/	/
32	731614105019	HARINI K Z	EEE A	/	/	X	/	X	X	/	/
33	731614105023	KANAGA PRIYA R	EEE A	/	/	X	/	X	X	/	/
34	731614105025	KARTHICK B	EEE A	/	/	X	a	X	X	/	/
35	731614105026	KARTHIGA N	EEE A	/	/	X	/	a	a	a	a
36	731614105027	KARTHIK T M Z	EEE A	/	/	X	/	X	X	/	/
37	731614105028	KAVIN KUMAR M	EEE A	/	/	X	/	X	X	/	/

PRINCIPAL

K. S. R. INSTITUTE FOR  
ENGINEERING AND TECHNOLOGY,  
K. S. R. KALVI NAGAR,  
TIRUCHENGODE - 637 215,  
NARAYALAI, TAMIL NADU.

S.No.	Reg No.	Name	Dept	21/11/11		22/11/11		23/11/11			
				FN	AN	FN	AN	FN	AN		
38	731614105029	KEERTHANA A	EEE A	/	/	X	/	X	a	/	/
39	731614105030	KESAVAN R	EEE A	/	/	X	/	X	X	/	/
40	731614105031	LAVANYA G	EEE A	/	/	X	/	X	X	/	/
41	731614105303	JEEVA V	EEE A	/	/	X	/	X	X	/	/
42	731614105304	KEERTHANA S	EEE A	/	/	X	/	X	X	/	/
43	731614105310	RAJ KUMAR G K	EEE A	/	/	X	/	X	X	/	/
44	731614105040	NOORNIHAR A	EEE B	/	/	X	/	P	P	P	P
45	731614105050	RANJITH T	EEE B	/	/	X	/	X	X	/	/
46	731614105055	SANGAVI K	EEE B	/	/	X	/	X	X	/	/
47	731614105067	THIYAGARAJAN S Z	EEE B	/	/	X	/	X	X	P	P
48	731614106003	ARTHI K	ECE	/	/	X	/	X	X	/	/
49	731614106004	ARUN S K	ECE	/	/	X	/	X	X	/	/
50	731614106009	DHIVYA DHARANI J	ECE	/	/	X	/	P	P	/	/
51	731614106013	ELIZABETH NJ	ECE	/	/	X	a	X	X	/	/
52	731614106018	HEMAVARTHINI M Z	ECE	/	P	X	/	X	X	/	/
53	731614106019	JANANI R	ECE	/	/	X	a	X	X	/	/
54	731614106020	JANANI T	ECE	/	/	P	P	P	a	a	a
55	731614106021	JANANI V.S Z	ECE	/	/	X	/	X	X	/	/
56	731614106022	JAYASHREE S	ECE	/	/	X	a	X	X	/	/
57	731614106024	KAAVIYA M	ECE	/	/	X	/	X	X	/	/
58	731614106030	KARTHIKA S	ECE	/	/	X	/	X	X	/	/
59	731614106034	KEERTHANA S	ECE	/	/	X	/	X	X	a	a
60	731614106036	KRISHNAA M	ECE	P	P	X	/	P	P	/	/
61	731614106037	LOGANATHAN S	ECE	/	/	X	/	X	X	/	/
62	731614106039	LOKESH KUMAR V Z	ECE	/	/	X	/	P	P	P	P
63	731614106044	MANOJ KUMAR K Z	ECE	/	/	X	/	X	X	P	P
64	731614106053	POONGODI S	ECE	/	/	X	/	X	X	/	/
65	731614106059	PRIYA R	ECE	/	/	X	/	X	X	/	/
66	731614106062	RAVI S Z	ECE	/	/	X	/	X	X	/	/
67	731614106064	SANGEETHA N	ECE	/	/	X	/	X	X	/	/
68	731614106065	SANKARI M Z	ECE	/	/	P	P	X	X	/	/
69	731614106067	SARAVANAN R	ECE	/	/	X	/	X	X	a	a
70	731614106074	SIVA RANJANI .P	ECE	/	/	X	a	X	X	/	/
71	731614106075	SOUNDHARYA V	ECE	/	/	X	/	X	X	a	a
72	731614106076	SRIDHAR T Z	ECE	/	/	P	/	X	X	/	/
73	731614106079	SUGUMAR S	ECE	a	a	a	a	P	P	P	P
74	731614106080	SURIYA V	ECE	/	/	/	/	X	X	/	/
PRESENT											
ABSENT											
PERMISSION											
OD											

PRINCIPAL,  
K. S. R. INSTITUTE FOR  
ENGINEERING AND TECHNOLOGY,  
K. S. R. CALYANAGAR,  
TIRUCHENGODE - 637 215,  
NAMAKKAL Dt, TAMIL NADU.

**K S R INSTITUTE FOR ENGINEERING AND TECHNOLOGY, TIRUCHENGODE - 637215****TRAINING & PLACEMENT CELL - Six Phase Training Programme**

BATCH: 2014 - 2018

ACADEMIC YEAR: 2017 - 2018 (ODD)

31.08.2017

**Fore Noon session**

S.NO	BRANCH	PRP			
		STRENGTH	PRESENT	ABSENT	LEAVE
1	CSE	16	12	1	3
2	ECE - A & B	27	25	1	1
3	EEE - A & B	23	23	0	0
4	IT	7	0	0	7
<b>Total</b>		<b>73</b>	<b>60</b>	<b>2</b>	<b>11</b>

S.NO	BRANCH	Non PRP			
		STRENGTH	PRESENT	ABSENT	LEAVE
1	CSE	16	12	1	3
2	ECE - A & B	27	25	1	1
3	EEE - A & B	23	23	0	0
4	IT	7	7	0	0
<b>Total</b>		<b>73</b>	<b>67</b>	<b>2</b>	<b>4</b>

  
T & P OFFICER

  
T & P COORDINATOR

  
PRINCIPAL

  
PRINCIPAL,  
K. S. R. INSTITUTE FOR  
ENGINEERING AND TECHNOLOGY,  
K. S. R. KALVI NAGAR,  
TIRUCHENGODE - 637 215,  
NAMAYKAL DI, TAMIL NADU.

## Fore Noon session

S.NO	BRANCH	PRP			
		STRENGTH	PRESENT	ABSENT	LEAVE
1	CSE	16	12	3	1
2	ECE - A & B	27	24	2	1
3	EEE - A & B	23	23	0	0
4	IT	7	7	0	0
<b>Total</b>		<b>73</b>	<b>66</b>	<b>5</b>	<b>2</b>

S.NO	BRANCH	Non PRP			
		STRENGTH	PRESENT	ABSENT	LEAVE
1	CSE	16	12	3	1
2	ECE - A & B	27	20	5	2
3	EEE - A & B	23	19	4	0
4	IT	7	7	0	0
<b>Total</b>		<b>73</b>	<b>58</b>	<b>12</b>	<b>3</b>

 T & P OFFICER

 T & P COORDINATOR

 PRINCIPAL

 PRINCIPAL,  
 K. S. R. INSTITUTE FOR  
 ENGINEERING AND TECHNOLOGY,  
 K. S. R. KALVI NAGAR,  
 TIRUCHENGODE - 637 215,  
 NAMAKKAL DISTRICT, TAMIL NADU.

## Fore Noon session

S.NO	BRANCH	PRP			
		STRENGTH	PRESENT	ABSENT	LEAVE
1	CSE	16	13	2	1
2	ECE - A & B	27	22	1	4
3	EEE - A & B	23	21	1	1
4	IT	7	6	0	1
Total		73	62	4	7

S.NO	BRANCH	Non PRP			
		STRENGTH	PRESENT	ABSENT	LEAVE
1	CSE	16	12	3	2
2	ECE - A & B	27	22	1	4
3	EEE - A & B	23	20	2	1
4	IT	7	6	0	1
Total		73	60	6	8

  
T & P OFFICER

  
T & P COORDINATOR

  
PRINCIPAL

  
PRINCIPAL,  
K. S. R. INSTITUTE FOR  
ENGINEERING AND TECHNOLOGY,  
K. S. R. KALVI NAGAR,  
TIRUCHENGODE - 637 215,  
NAMAKKAL DT, TAMIL NADU.

## Fore Noon session

S.NO	BRANCH	PRP			
		STRENGTH	PRESENT	ABSENT	LEAVE
1	CSE	16	6	8	2
2	ECE - A & B	27	20	4	3
3	EEE - A & B	23	19	2	2
4	IT	7	3	1	3
<b>Total</b>		<b>73</b>	<b>48</b>	<b>15</b>	<b>10</b>

S.NO	BRANCH	Non PRP			
		STRENGTH	PRESENT	ABSENT	LEAVE
1	CSE	16	7	8	1
2	ECE - A & B	27	20	4	3
3	EEE - A & B	23	19	2	2
4	IT	7	2	2	3
<b>Total</b>		<b>73</b>	<b>48</b>	<b>16</b>	<b>9</b>

*[Signature]*  
T & P OFFICER

*[Signature]*  
T & P COORDINATOR

*[Signature]*  
PRINCIPAL

PRINCIPAL  
K. S. R. INSTITUTE FOR  
ENGINEERING AND TECHNOLOGY,  
K. S. R. KALMI LAGAR,  
TIRUCHENGODE - 637 215,  
NARAIKAL Dt, TAMIL NADU.

K S R INSTITUTE FOR ENGINEERING AND TECHNOLOGY  
TIRUCHENGODE - 637 215

TRAINING PROGRAMME FEEDBACK FORM



Name of the Student: KESAVAN.R

Branch: EEE

Year / Sem: V / 7

1. Name of the Training: ~~Santhosh~~ Logical Reasoning

2. Name of the Trainer: Santhosh

3. Students rating of Trainers :

S. No.	Date	Subject	Rating (✓)			
			Excellent	Very good	Good	Average
1	1.9.17	Seating arrangement Blood relation	✓			

4. Two positive points about the programme:

\* Good.

5. Suggestions for improvement:

Date: 1.9.17

R. Kesavan  
Signature

K S R INSTITUTE FOR ENGINEERING AND TECHNOLOGY  
TIRUCHENGODE - 637 215

TRAINING PROGRAMME FEEDBACK FORM



Name of the Student: KESAVAN.R

Branch: EEE

Year / Sem: 4 / 7

4. Name of the Training: Quantitative Aptitude

5. Name of the Trainer: Poovarasan

6. Students rating of Trainers :

S. No.	Date	Subject	Rating (✓)			
			Excellent	Very good	Good	Average
1	1.9.17	Boats and currents Ratio, calendar.	✓			

4. Two positive points about the programme:

\* Good.

5. Suggestions for improvement:

Date:

  
PRINCIPAL,  
K. S. R. INSTITUTE FOR  
ENGINEERING AND TECHNOLOGY,  
K. S. ALMUDI NAGAR,  
TIRUCHENGODE - 637 215,  
NANAKMAL Dt, TAMIL NADU.

R. Kesavan  
Signature



Name of the Student: Hemavarthini OM

Branch: ECE - A

Year / Sem: IV / 7th sem

1. Name of the Training: REASONING

2. Name of the Trainer: M. SANTHOSH

3. Students rating of Trainers :

S. No.	Date	Subject	Rating (✓)			
			Excellent	Very good	Good	Average
1	1.9.2017	REASONING		✓		

4. Two positive points about the programme:

\* gave clear explanation and covered the topics

5. Suggestions for improvement:

M. Henu  
Signature

Date: 1.9.2017



Name of the Student: SOUNDARYA

Branch: ECE - B

Year / Sem: IV / 7th SEM.

4. Name of the Training: QUANTZ

5. Name of the Trainer: POONARASAN

6. Students rating of Trainers :

S. No.	Date	Subject	Rating (✓)			
			Excellent	Very good	Good	Average
1	1.9.2017	QUANTZ				✓

4. Two positive points about the programme:

5. Suggestions for improvement:

\* No clarity of explanation  
\* solved only 6 to 7 problems

Date: 1.9.2017

Soundarya  
Signature



TRAINING PROGRAMME FEEDBACK FORM

Name of the Student: C. Anish Sankar

Branch: CSE

Year / Sem: V - 7

4. Name of the Training: REASONING

5. Name of the Trainer: SANTHOSH

6. Students rating of Trainers :

S. No.	Date	Subject	Rating (✓)			
			Excellent	Very good	Good	Average
1	2 sept 2017	Data Arrangement Most logical choices	✓			

4. Two positive points about the programme:

- \* Solved many problems.
- \* Interactive Trainer.

5. Suggestions for improvement:

- \* Nil

Date:

Anish Sankar  
Signature

TRAINING PROGRAMME FEEDBACK FORM

Name of the Student: M. Sowanthiya

Branch: B.Tech - IT

Year / Sem: IV / VI

1. Name of the Training: Reasoning

2. Name of the Trainer: Santhosh.

3. Students rating of Trainers :

S. No.	Date	Subject	Rating (✓)			
			Excellent	Very good	Good	Average
1	2.9.17	Data Arrangement Data Sufficiency	✓			

4. Two positive points about the programme:

- His teaching is good.
- He understood a concept clearly.

5. Suggestions for improvement:

Santhosh  
PRINCIPAL,  
K. S. R. INSTITUTE FOR  
ENGINEERING AND TECHNOLOGY,  
K. S. R. KALYANAGAR,  
TIRUCHENGODE - 637 215,  
NANDIGAL BI, TN. INDIA.

Signature

K S R INSTITUTE FOR ENGINEERING AND TECHNOLOGY  
TIRUCHENGODE - 637 215

TRAINING PROGRAMME FEEDBACK FORM



Name of the Student: M. Anitha

Branch: EES

Year / Sem: IV / VII

1. Name of the Training: Quantative Aptitude

2. Name of the Trainer: Sathish Kumar.

3. Students rating of Trainers :

S. No.	Date	Subject	Rating (✓)			
			Excellent	Very good	Good	Average
1	3/9/17	Quantative Aptitude	✓			

Clock, geometry,

4. Two positive points about the programme:

We learnt the <sup>same</sup> shortcuts about 6 topics.

5. Suggestions for improvement:

Date: 3/9/17

[Signature]  
Signature

K S R INSTITUTE FOR ENGINEERING AND TECHNOLOGY  
TIRUCHENGODE - 637 215

TRAINING PROGRAMME FEEDBACK FORM



Name of the Student: M. Anitha

Branch: EES

Year / Sem: IV / VII

4. Name of the Training: Quantative Aptitude

5. Name of the Trainer: Sathish Kumar

6. Students rating of Trainers :

S. No.	Date	Subject	Rating (✓)			
			Excellent	Very good	Good	Average
1	3/9/17	Profit & loss, Percentage, Ages	✓			

Allegation & mixer

4. Two positive points about the programme:

We learnt more things about many topics.

5. Suggestions for improvement:

Date: 3/9/17

PRINCIPAL,  
K. S. R. INSTITUTE FOR  
ENGINEERING AND TECHNOLOGY,  
K. S. R. KALVI NAGAR,  
TIRUCHENGODE - 637 215,  
NAMAKKAL Dt, TAMIL NADU.

[Signature]  
Signature

Ref: KSRIET/T&P/CIR/2017-18

Date: 02.08.2017

This is to inform that all the HoDs and department Training and Placement coordinators that the Four days (04.08.2017 to 08.08.2017) Aptitude Training Programme ( Phase II) & Online Assessment for IV year students by Six Phrases during the academic year 2017 - 2018 (Odd Sem) has been scheduled as given below. All the registered students should attend the Training Programme without fail. If any student skips this Training Programme without proper permission from the respective HoDs, he / she will not be permitted for any further Training Programme and campus recruitment process. Proper Dress Code is mandatory.

**TIMINGS:**

**FORENOON SESSION:**

**09:00 - 12:30 (Break - 10:45 - 11:00)**

**LUNCH: 12:30 - 01:30**

**AFTERNOON SESSION:**

**01:30 - 04:30 (Break - 02:30 - 02:45)**

**Online Assessment: 05:00 - 06:30**

  
T&P OFFICER

  
T&P COORDINATOR

  
PRINCIPAL

Copy to:

1. All HoDs

  
PRINCIPAL,  
K S R INSTITUTE FOR  
ENGINEERING AND TECHNOLOGY,  
K. S. R. KALVI NAGAR,  
TIRUCHENGODE - 637 215,  
NARAYKAL DI, TAMIL NADU.

## K S R - Training Plan

②

Group 1	FN - Session 1	FN - Session 2	AF - Session 1	AF - Session 2
Batch 1	A1/R1	V1	Lab Test	Lab Test
Batch 2	V1	A1/R1	Lab Test	Lab Test

A1/R1	Sharmila
V1	Krishnanand
Lab Test	XXXXXXXXXX
Lab Test	XXXXXXXXXX

Group 2	FN - Session 1	FN - Session 2	AF - Session 1	AF - Session 2
Batch 3	Lab Test	Lab Test	A1/R1	V1
Batch 4	Lab Test	Lab Test	V1	A1/R1

A1/R1	Sharmila
V1	Krishnanand
Lab Test	XXXXXXXXXX
Lab Test	XXXXXXXXXX

### Topics

Day 1	A1	<u>Percentages</u> , <u>Profit And Loss</u> <u>Direction Sense</u> Sentence Correction ✓
	R1	
	V1	
Day 2	A1	<i>Proba</i> <u>Time And Work</u> , <u>Pipes and Cistern</u> <u>Coding And Decoding</u> Reading Comprehension ✓ <i>Theme def</i>
	R1	
	V1	
Day 3	A1	<u>Sequence and Series</u> ✓ <u>Syllogism</u> <u>Jumbled Sentences</u> ✓
	R1	
	V1	
Day 4	A1	<u>Time , speed , distance</u> ✓ <u>Blood Relations</u> <u>Verbal Analogies</u> ✓
	R1	
	V1	

4/8/17, 5/8/17, 7/8/17, 8/8/17

  
 PRINCIPAL,  
 K. S. R. INSTITUTE FOR  
 ENGINEERING AND TECHNOLOGY,  
 K. S. R. KALVA NAGAR,  
 TIRUCHENGODE - 687 215,  
 NAMAKKAL Dt, TAMIL NADU.

Day	Title	Topics
Day 1	Aptitude	Quantitative Aptitude New -- Percentages -- Test 1
	Reasoning	Reasoning Aptitude New -- Direction Sense- Test 1
	Verbal	Verbal Aptitude New -- Sentence Correction -- Test 1
Day 2	Aptitude	Quantitative Aptitude New -- Time And Work-- Test 1
	Reasoning	Reasoning Aptitude New -- Coding And Decoding-- Test 1
	Verbal	Verbal Aptitude New -- Reading Comprehension -- Test 1
Day 3	Aptitude	Quantitative Aptitude New -- Sequence And Series -- Test 1
	Reasoning	Reasoning Aptitude New -- Syllogism -- Test 1
	Verbal	Verbal Aptitude New -- Jumbled Sentence -- Test 1
Day 4	Aptitude	Quantitative Aptitude New -- Time , Speed , Distance -- Test 1
	Reasoning	Reasoning Aptitude New -- Blood Relations -- Test 1
	Verbal	Verbal Aptitude New -- Verbal Analogies -- Test 1
Day 5	Aptitude	CTS Model Test 1 --- 22
	Reasoning	
	Verbal	
Day 6	Aptitude	CTS Model Test 1 --- 21
	Reasoning	
	Verbal	
Day 7	Aptitude	CTS Model Test 1 --- 20
	Reasoning	
	Verbal	
Day 8	Aptitude	CTS Model Test 1 --- 19
	Reasoning	
	Verbal	
Day 9	Aptitude	CTS Model Test 1 --- 18
	Reasoning	
	Verbal	
Day 10	Aptitude	CTS Model Test 1 --- 17
	Reasoning	
	Verbal	
Day 11	Aptitude	CTS Model Test 1 --- 16
	Reasoning	
	Verbal	
Day 12	Aptitude	CTS Model Test 1 --- 15
	Reasoning	
	Verbal	

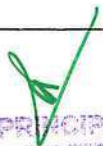
  
**PRINCIPAL,**  
**K. S. R. INSTITUTE FOR**  
**ENGINEERING AND TECHNOLOGY,**  
**K. S. R. KALVI NAGAR,**  
**THIRUCHENGODE - 687 215,**  
**NAMAKKAL DISTRICT, TAMIL NADU.**

## Training and Placement Cell

## SIX PHASE TRAINING PROGRAMME - PHASE - 2

BATCH : 2014 - 2018

Academic Year: 2017 - 2018

Sem: IV / VII

BATCH - 1

Staff Incharge:

Mech

S.No.	Reg No.	Name	Dept	04.08.2017		05.08.2017		07.08.2017		08.08.2017	
				FN	AN	FN	AN	FN	AN	FN	AN
1	731614104007	M.DEEPAK FERNAND EZ	CSE	/	/	/	/	/	/	/	/
2	731614105062	S.SURYA	EEE	/	/	/	/	/	/	/	/
3	731614105035	MOULIDHA RAN	EEE	P	P	/	/	/	/	/	/
4	731614105039	T.NANDHINI	EEE	P	P	/	/	/	/	/	/
5	731614105059	SOUNDAR AKUMAR C	EEE	/	/	/	/	/	/	/	/
6	731614105017	HARIHARA N.G	EEE	/	/	/	/	/	/	/	/
7	731614106011	DIVYA.S	ECE	/	/	/	/	/	/	/	/
8	731614106017	GOVINDARAJ M	ECE	/	/	/	/	/	/	/	/
9	731614106001	ABINAYA R	ECE	P	P	/	/	/	/	/	/
10	731614106015	GOKUL RAJ K.N	ECE	/	/	/	/	/	/	/	/
11	731614106046	NANDHINI M	ECE	/	/	/	/	/	/	/	/
12	731614106010	DHIVYA PRABHA P	ECE	/	/	/	/	/	/	/	/
13	731614106023	JOTHIPRA KASH R	ECE	/	/	/	/	/	/	/	/
14	731614106077	SUBATHRA S	ECE	/	/	/	/	/	/	/	/
15	731614106025	KALAI PRIYA N	ECE	/	/	/	/	/	/	/	/
16	731614106052	PAVITHRA N S	ECE	/	/	/	/	/	/	/	/
17	731614114007	ANAND S	MECH	/	/	/	/	/	/	/	/
18	731614114018	ARUL PRAKASH. P	MECH	/	/	/	/	/	/	/	/
19	731614114028	R.DEVAN	MECH	/	/	P	P	/	/	/	/
20	731614114012	S.ARAVIND HARA J	MECH	/	/	/	/	/	/	/	/
21	731614114034	DINESH KUMAR.M	MECH	/	/	/	/	/	/	/	/
22	731614114038	GOKUL KUMAR R	MECH	/	/	/	/	/	/	/	/
23	731614114048	HARIHARA N.S	MECH	/	/	/	/	/	/	/	/
24	731613114102	Nivasan K	MECH	/	/	/	/	/	/	/	/
25	731613114143	Sukruth B	MECH	/	/	/	/	/	/	/	/
26	731613114144	Suresh P	MECH	/	/	/	/	/	/	/	/
27	731614114069	Lavanya S	MECH	/	/	/	/	/	/	/	/
28	731614114087	MOHAN S	MECH	/	/	/	/	/	/	/	/
29	731614114142	Srinivasan P	MECH	/	/	/	/	/	/	/	/
30	731614114152	K.THIRULOGA SNTHAR	MECH	/	/	/	/	/	/	/	/
31	731614114163	Vijay S	MECH	/	/	/	/	/	/	/	/
32	731614114701	Shankarram R	MECH	/	/	/	/	/	/	/	/
33	731614114704	Arun SV	MECH	/	/	/	/	/	/	/	/
34	731614114003	M.AJITHKU MAR	MECH	/	/	/	/	/	/	/	/

## Training and Placement Cell

## SIX PHASE TRAINING PROGRAMME - PHASE - 2

BATCH : 2014 - 2018

Academic Year: 2017 - 2018

Sem: IV / VII

BATCH - 1

Staff Incharge:

S.No.	Reg No.	Name	Dept	04.08.2017		05.08.2017		07.08.2017		08.08.2017	
				FN	AN	FN	AN	FN	AN	FN	AN
35	731614114066	KISHORKU MARAN.S	MECH	/	/	/	/	/	/	/	/
36	731614114070	LAXMANA N M	MECH	/	/	/	/	/	/	/	/
37	731614114036	EYAD MUHAMME D	MECH	/	/	/	/	/	/	/	/
38	731614114041	P.GOWTHA M	MECH	/	/	/	/	/	/	/	/
39	731614114027	DEEPANC HAKRAVA RTHLS	MECH	/	/	/	/	/	/	/	/
40	731614114011	ARAVINDH AN A J	MECH	P	P	P	P	/	/	/	/
41	731614114055	KAMALAKA NNAN	MECH	/	/	/	/	/	/	/	/
42	731614114316	MUDALIYA R VISHNU PARASUR AMAN	MECH	/	/	/	/	/	/	/	/
43	731614114098	NAVEEN.P	MECH	P	P	/	/	/	/	/	/
44	731614114108	PRAKASH RAJ T	MECH	/	/	/	/	/	/	/	/
45	731614114043	S.GOWTHA MAN	MECH	/	/	/	/	/	/	/	/
46	731614114051	N.HARISHA NKAR	MECH	/	/	/	/	/	/	/	/
47	731614114059	S.KARTHI	MECH	/	/	/	/	/	/	/	/
48	731614114146	SURYA .M	MECH	/	/	/	P	/	/	/	/
49											
50											
PRESENT				42	43	46	44	48	48	48	48
ABSENT				2	01	-	1	-	-	-	-
PERMISSION				44	4	2	3	-	-	-	-
OD											

Session  
Theory  
Practice

Timingis  
FN: 09:15 to 12:30  
AN: 01:30 to 04:45

Venue  
101  
CAD LAB

Break Timings  
FN: 10:45 to 11:00  
AN: 03:00 to 03:15

Practice Lab  
01:30 - 02:30  
02:30 - 03:00  
Practice Lab  
03:15 - 04:15  
04:15 - 04:45

Session - I  
Test - 01 Hour  
Discussion- 30 Mints  
Session - II  
Test - 01 Hour  
Discussion- 30 Mints

Tpoic  
App + Verbal  
Tpoic  
App + Verbal

PRINCIPAL,  
K. S. R. INSTITUTE FOR  
ENGINEERING AND TECHNOLOGY,  
K. S. R. KALVI NAGAR,  
TIRUCHENGODE - 617 215,  
KARNATAKA DL TAMIL NADU.

## Training and Placement Cell

## SIX PHASE TRAINING PROGRAMME - PHASE - II

BATCH : 2014 - 2018

Academic Year: 2017 - 2018

Sem: IV / VII

BATCH - 2

Incharge:

Mech

S.No.	Reg No.	Name	Dept	04.08.2017		05.08.2017		07.08.2017		08.08.2017	
				FN	AN	FN	AN	FN	AN	FN	AN
1	731614105068	E.UTHIRAK UMAR 1	EEE	/	X	/	/	/	/	/	/
2	731614105072	VIJAY R 2	EEE	a	X	/	/	/	/	/	/
3	731614105073	N.VIJAYAN 3	EEE	o	X	/	/	/	/	/	/
4	731614105033	MATHANA GOPAL G 4	EEE	a	a	a	a	/	/	/	/
5	731614105074	R.VINOTH KUMAR 5	EEE	/	X	/	/	/	/	/	/
6	731614105053	ROKESH KUMAR R 6	EEE	R	P	/	/	/	/	/	/
7	731614106005	ATCHAYA R 7	ECE	/	X	/	/	/	/	/	/
8	731614106008	DEEPANK UMARS 8	ECE	/	X	/	/	/	/	/	/
9	731614106063	RAVI VARMA B 9	ECE	/	X	/	/	/	/	/	/
10	731614106301	DEEPAN K 10	ECE	/	X	/	/	/	/	/	/
11	731614106007	DEEPAKRAJU C 11	ECE	/	X	/	/	/	/	/	/
12	731614106027	KANMANI R 12	ECE	/	X	/	/	/	/	/	/
13	731614106049	OVIYA T 13	ECE	/	X	/	/	/	/	/	/
14	731614106085	VINOTHINI P 14	ECE	/	X	/	/	/	/	/	/
15	731614104029	RAKUL M 15	CSE	a	a	/	/	/	/	/	/
16	731614104306	SABARINA THANS 16	CSE	/	X	/	/	/	/	/	/
17	731614104037	SELVAGAN APATHIR 17	CSE	/	X	a	a	/	/	/	/
18	731614114001	ABHIRAM T 18	MECH	/	X	/	/	/	/	/	/
19	731614114013	K.KARAVINT H 19	MECH	a	a	P	P	/	/	/	/
20	731614114015	ARJUN B 20	MECH	/	X	/	/	/	/	/	/
21	731614114023	BALAJIL 21	MECH	/	X	/	/	/	/	/	/
22	731614114042	GOWTHAM 22	MECH	/	X	/	/	/	/	/	/
23	731614114124	SABAREESAN M 23	MECH	/	X	/	/	/	/	/	/
24	731614114166	VIJAYAKU MAR M 24	MECH	/	X	/	/	/	/	/	/
25	731614114303	DINESHKU MAR R 25	MECH	/	X	P	P	/	/	/	/
26	731613114123	RanjithKumar S 26	MECH	/	X	/	/	/	/	/	/
27	731614114049	S.HARIHARASUDAN 27	MECH	/	X	/	/	/	/	/	/
28	731614114054	Jayaprakash R 28	MECH	/	X	/	/	/	/	/	/
29	731614114077	Manoj Kumar R 29	MECH	/	X	/	/	/	/	/	/
30	731614114084	Mohammed Sirajudeen 30	MECH	/	X	/	/	/	/	/	/
31	731614114095	Nainar Mohammad 31	MECH	/	X	/	/	/	/	/	/
32	731614114101	Nethaji M 32	MECH	/	X	/	/	/	/	/	/
33	731614114126	Sabarigiri G 33	MECH	/	X	/	/	/	/	/	/
34	731614114141	V Srinath 34	MECH	/	X	/	/	/	/	/	/



S.No.	Reg No.	Name	Dept	04.06.2017		05.06.2017		07.06.2017		08.06.2017	
				FN	AN	FN	AN	FN	AN	FN	AN
35	731614114312	Kaviyarasan S 35	MECH	/	X	/	X	/	/	/	/
36	731614114313	Logesh A 36	MECH	/	X	/	/	/	/	/	/
37	731614114020	ARUNKUM AR 37	MECH	/	X	/	/	/	/	/	/
38	731614114033	DINESH.S. V 38	MECH	/	X	/	/	/	/	/	/
39	731614114037	GANESHK ARTHIK 39	MECH	/	X	/	/	/	/	/	/
40	731614114072	A.LOGESH KUMAR 40	MECH	/	X	/	/	/	/	/	/
41	731614114106	PRADEEP N 41	MECH	/	X	/	/	/	/	/	/
42	731614114311	JEEVA S 42	MECH	/	X	/	/	/	/	/	/
43	731614114039	L.GOKULP RASATH 43	MECH	/	X	/	/	/	/	/	/
44	731614114046	HARIHARA N.K 44	MECH	/	X	/	/	/	/	/	/
45	731614114050	HARISH 45	MECH	/	X	/	/	/	/	/	/
46	731614114092	MUNIRAJ R 46	MECH	/	X	/	/	/	/	/	/
47	731614114110	PRASANTH.C 47	MECH	/	X	/	/	/	/	/	/
48	731614114134	K.SATHISH RAJ 48	MECH	/	X	/	/	/	/	/	/
49	731614114151	S.STARUN CHOUHAN 49	MECH	/	X	/	/	/	/	/	/
50											
PRESENT				43		45	45	49	49	49	49
ABSENT				6		02	02				
PERMISSION				-		02	02				
OD						-	-				

Session  
Theory  
Practice

Timingis  
FN: 09:15 to 12:30  
AN: 01:30 to 04:45

Break Timingis  
FN: 10:45 to 11:00  
AN: 03:00 to 03:15

Practice Lab  
01:30 - 02:30  
02:30 - 03:00  
Practice Lab  
03:15 - 04:15  
04:15 - 04:45

Session - I  
Test - 01 Hour  
Discussion- 30 Mints  
Session - II  
Test - 01 Hour  
Discussion- 30 Mints

PRINCIPAL,  
K. S. R. INSTITUTE FOR  
ENGINEERING AND TECHNOLOGY,  
K. S. R. KALVI NAGAR,  
TIRUCHENGOODE - 637 215,  
NAMAKKAL DISTRICT, TAMIL NADU.

## Training and Placement Cell

## SIX PHASE TRAINING PROGRAMME - PHASE - II

BATCH : 2014 - 2018

Academic Year: 2017 - 2018

'Sem: IV / VII

BATCH - 3

Incharge:

EEE

S.No.	Reg No.	Name	Dept	04.08.2017		05.08.2017		07.08.2017		08.08.2017	
				FN	AN	FN	AN	FN	AN	FN	AN
1	731614106012	DURKA DEVI S	ECE	/	/	X	/	/	/	/	/
2	731614106032	KATHIRES H S	ECE	/	/	X	/	/	/	/	/
3	731614106040	MADHU KRISHNA. B	ECE	a	a	a	a	/	/	/	/
4	731614106047	NANDHINI R	ECE	/	/	X	/	/	/	/	/
5	731614106068	SASITHA M	ECE	/	/	X	/	/	/	/	/
6	731614106311	UDHAYAK UMAR B	ECE	/	/	X	/	/	/	/	/
7	731614106006	BARATH KUMAR M	ECE	/	/	X	/	/	/	/	/
8	731614106066	SANTHOS H E	ECE	/	/	X	/	/	/	/	/
9	731614106070	SHARANY A A	ECE	/	/	X	/	/	/	/	/
10	731614104012	JAISRE.A	CSE	/	/	X	/	/	/	a	a
11	731614104305	PUGALMA NLP	CSE	/	/	X	/	a	a	/	/
12	731614205005	KARTHIK P	IT	/	/	/	/	/	/	/	/
13	731614205303	GOKUL K	IT	/	/	/	/	/	/	/	/
14	731614105004	BALACHAN DAR K R	EEE	/	/	X	/	/	/	/	/
15	731614105021	HARIRAMU	EEE	/	/	X	/	/	/	/	/
16	731614105041	PRAKASH. C	EEE	/	/	X	/	/	/	/	/
17	731614105057	SIVAGURU U	EEE	/	/	a	a	/	/	/	/
18	731614105076	B.YOKESH WARAN	EEE	/	/	X	/	/	/	/	/
19	731614105009	DHIVAGARA	EEE	/	/	X	/	/	/	/	/
20	731614105054	A.SABARE ESWARAN	EEE	/	/	X	/	/	/	/	/
21	731614105305	D.MADHAN	EEE	/	/	X	/	/	/	/	/
22	731614105003	ARAVINDH AN B	EEE	/	/	X	/	/	/	/	/
23	731614105042	PRAVEENK UMAR B	EEE	/	/	X	/	/	/	/	/
24	731614105058	SOMA SUNDARA M.R	EEE	/	/	X	/	/	/	/	/
25	731614105060	STEEPHAN SIBU	EEE	/	/	X	/	/	/	/	/
26	731614105312	THIRUMOO RTHI G	EEE	/	/	X	/	/	/	/	/
27	731614114024	BARATHRA J	MECH	/	/	X	/	/	/	a	a
28	731614114029	N.DEVARA J	MECH	/	/	X	/	/	/	/	/
29	731614114064	KAVIYARA SU	MECH	a	a	/	/	/	/	/	/
30	731614114133	SATHISH.K	MECH	/	/	X	/	/	/	/	/
31	731614114154	VASANTH S	MECH	/	/	X	/	P	P	/	/
32	731614114031	K.DHANUSH KUMAR	MECH	/	/	X	/	/	/	/	/
33	731614114090	Muhilarasu S	MECH	/	/	X	/	/	/	P	P
34	731614114115	RahulKumar K	MECH	/	/	X	/	a	a	/	/

PRINCIPAL,  
K S R INSTITUTE FOR  
ENGINEERING AND TECHNOLOGY,  
K. S. R. KALU NAGAR,  
TIRUCHENGODE - 637 215,  
TAMIL NADU.

S.No.	Reg No.	Name	Dept	08/06/2017		09/06/2017		10/06/2017		11/06/2017	
				FN	AN	FN	AN	FN	AN	FN	AN
35	731614114132	Saravana Manoj S	MECH	/	/	X	/	/	/	/	/
36	731614114136	Shivakumar S	MECH	/	/	X	/	/	/	/	/
37	731614114139	Sridhar K	MECH	/	/	X	/	/	/	/	/
38	731614114140	Sridhar R	MECH	/	/	X	/	/	/	a	a
39	731614114149	Tamilmani p	MECH	a	a	a	a	/	/	/	/
40	731614114160	Vignesh D	MECH	/	/	X	/	/	/	/	/
41	731614114309	Gopinath K	MECH	/	/	X	/	/	/	/	/
42	731614114315	S.MANJUN ATH	MECH	/	/	X	/	a	a	a	/
43	731614114062	KARTHIKE YAN S	MECH	/	/	X	/	/	/	/	/
44	731614114074	MAHENDR AN.A	MECH	/	/	X	/	/	/	/	/
45	731614114089	MUGILESH WARAN K	MECH	/	/	X	/	/	/	/	/
46	731614114114	RADHAKRI SHNAN S	MECH	/	/	X	/	P	P	/	/
47	731614114326	SURENDA R. A	MECH	/	/	X	/	/	/	/	/
48	731614114329	P.VENKAT ESH	MECH	/	/	X	/	/	/	/	/
50		Parisadharshini	ECE	/	/	X	/	/	/	/	/
PRESENT				48							
ABSENT				3							
PERMISSION											
OD											

51 731614104030 SARAVANA ABISHAK CSE / / X /

Session	Timingis	Break Timings
Practice	FN: 09:15 to 12:30	FN: 10:45 to 11:00
Theory	AN: 01:30 to 04:45	AN: 03:00 to 03:15
<b>Practice Lab</b>	<b>Session - I</b>	
09:15 - 10:15	Test - 01 Hour	
10:15 - 10:45	Discussion- 30 Mints	
<b>Practice Lab</b>	<b>Session - II</b>	
11:00 - 12:00	Test - 01 Hour	
12:00 - 12:30	Discussion- 30 Mints	

  
 PRINCIPAL,  
 K. S. R. INSTITUTE FOR  
 ENGINEERING AND TECHNOLOGY,  
 K. S. R. KALVI NAGAR,  
 TIRUCHENGODE - 637 215,  
 NAMAKKAL Dt, TAMIL NADU.

## Training and Placement Cell

## SIX PHASE TRAINING PROGRAMME - PHASE - II

BATCH : 2014 - 2018

Academic Year: 2017 - 2018

Sem: IV / VII

BATCH - 4

ECE

S.No.	Reg No.	Name	Dept	04.08.2017		05.08.2017		07.08.2017		08.08.2017	
				FN	AN	FN	AN	FN	AN	FN	AN
1	731614104033	SARAVANA ABISHEK.G	CSE	a	a	BATCH - 3					
2	731614106045	NAAGHA NAVEEN KUMAR V	ECE	/	/	/	/	/	/	/	/
3	731614106051	PARTHASA RATHI M M	ECE	/	/	/	/	/	/	/	/
4	731614106072	SINEHA N	ECE	/	/	/	/	/	/	/	/
5	731614106082	THAMARAI KANNAN S	ECE	/	/	/	/	a	a	/	/
6	731614106307	RANGANA THAN S	ECE	a	a	/	/	/	/	/	/
7	731614106054	PRADEEPA S	ECE	/	/	/	/	/	/	/	/
8	731614106303	DINESH T	ECE	/	/	/	/	/	/	/	/
9	731614106016	GOPIKA N	ECE	/	/	/	/	/	/	/	/
10	731614106035	KOWSALY A.M	ECE	/	/	/	/	/	/	/	/
11	731614106050	PADMAPRI YA E	ECE	/	/	/	/	/	/	/	/
12	731614106701	VIGNESHW AR B	ECE	/	/	/	/	/	/	/	/
13	731614106048	NIVETHA A	ECE	/	/	/	/	/	/	/	/
14	731614205013	VIJAY S	IT	/	/	/	/	/	/	P	P
15	731614205001	N. GNANASE KAR	IT	/	OP	OP	OP	a	a	/	/
16	731614205306	VINITHA K	IT	/	/	/	/	/	/	/	/
17	731614105077	V.YUVARAJ	EEE	/	/	/	/	/	/	/	/
18	731614105034	MOTHINATH	EEE	/	/	/	/	/	/	/	/
19	731613114017	Arjun T	MECH	/	/	/	/	/	/	/	/
20	731614114116	Rajasekar A	MECH	/	/	/	/	P	P	/	/
21	731614114122	Ranjithkumar M	MECH	/	/	/	/	/	/	/	/
22	731614114150	Tamilselva N s	MECH	/	/	/	/	/	/	/	/
23	731614114155	Velmurugan M	MECH	a	a	/	/	/	/	/	/
24	731614114156	Venkadesh S	MECH	/	/	/	/	/	/	P	P
25	731614114159	Venugopal V	MECH	a	a	a	a	/	/	/	/
26	731614114088	MOHAN RAJ R	MECH	/	/	a	a	/	/	/	/
27	731614114094	S.MUTHURAJ	MECH	/	/	/	/	/	/	/	/
28	731614114317	NAVEEN.C	MECH	a	a	a	a	a	a	a	a
29	731614114030	A.DHANAS EKARAN	MECH	/	/	/	/	/	/	/	/
30	731614114052	IZAZS AHAMMED	MECH	/	/	/	/	/	/	P	P
31	731614114061	KARTHIKE YAN.S	MECH	/	/	/	/	/	/	/	/
32	731614114068	KUMARAN E	MECH	/	/	/	/	P	P	/	/
33	731614114091	MUHINTHAN R. S	MECH	/	/	/	/	/	/	/	/
34	731614114097	NARESHK UMAR.B	MECH	/	/	/	/	/	/	/	/

PRINCIPAL  
K S R INSTITUTE FOR  
ENGINEERING AND TECHNOLOGY,  
K. S. R. CAMPUS,  
TIRUCHENGODE - 637 215,  
NAGALAND DISTRICT, TAMIL NADU.

S.No.	Reg No.	Name	Dept	FN	AN	FN	AN	FN	AN	FN	AN
35	731614114314	D.MADHAN RAJ	MECH	/	/	/	/	/	/	/	/
36	731614114331	VIVEKKUMAR G	MECH	/	/	/	/	/	/	/	/
37	731614114004	AJITHKUMAR M	MECH	/	/	/	/	/	/	/	/
38	731614114083	MOHAMED RIYAZ M	MECH	/	/	/	/	/	/	/	/
39	731614114164	A.VINITHKUMAR	MECH	/	P	a	a	/	/	/	/
40	731614114032	DHAYANITHIR	MECH	/	/	/	/	/	/	/	/
41	731614114040	GOKUL RAJ M	MECH	/	/	/	/	/	/	/	/
42	731614114047	HARIHARAN M	MECH	/	/	/	/	/	/	/	/
43	731614114080	MITHUN CHAKRAVARTI Y	MECH	/	/	a	a	/	/	/	/
44	731614114085	MOHAMED YUNUS A	MECH	/	/	/	/	P	P	/	/
45	731614114087b	MOHAN S P	MECH	/	/	/	/	/	/	/	/
46	731614114128	SAM PRAKASH S	MECH	/	/	/	/	/	/	/	/
47	731614114057	KARTHICK P	MECH	/	/	/	/	/	/	/	/
48	731614114079	MEIPRAKASH K	MECH	/	/	/	/	/	/	/	/
49	731614106002	Aaravind K	ECE	/	/	/	/	/	/	/	/
50	731614114121	C. Ravi Shankar	MECH	/	/	/	/	P	P	/	/
PRESENT											
ABSENT											
PERMISSION											
OD											

Session  
Practice  
Theory

Timingis

FN: 09:15 to 12:30 9.15 - 12.15  
AN: 01:30 to 04:45 1.15 - 4.20

Break Timings

FN: 10:45 to 11:00 / 10.30 - 10.45  
AN: 03:00 to 03:15 / no Break  
lunch - 12.15 - 1.15

Practice Lab  
9.00 - 10.30 / 09:15 - 10:15  
10.45 - 12.15 / 10:15 - 10:45  
Practice Lab  
11:00 - 12:00  
12:00 - 12:30

Session - I  
Test - 01 Hour  
Discussion - 30 Mints  
Session - II  
Test - 01 Hour  
Discussion - 30 Mints

PRINCIPAL  
K. S. R. INSTITUTE FOR  
ENGINEERING AND TECHNOLOGY,  
K. S. R. KALVI NAGAR,  
TIRUCHENGODE - 637 215,  
NAMANKAL DI, TAMIL NADU.

BATCH: 2014 - 2018

ACADEMIC YEAR: 2017 - 2018 (ODD)

04.08.2017

## Fore Noon session

S.NO	BRANCH	Non PRP			
		STRENGTH	PRESENT	ABSENT	LEAVE
1	CSE	7	6	1	0
2	ECE - A & B	41	38	1	2
3	EEE - A & B	26	23	2	1
4	IT	5	5	0	0
5	MECH A, B & C	117	109	3	5
<b>Total</b>		<b>196</b>	<b>181</b>	<b>7</b>	<b>8</b>

S.NO	BRANCH	Non PRP			
		STRENGTH	PRESENT	ABSENT	LEAVE
1	CSE	7	6	1	0
2	ECE - A & B	41	38	1	2
3	EEE - A & B	26	23	2	1
4	IT	5	5	0	0
5	MECH A, B & C	117	109	3	5
<b>Total</b>		<b>196</b>	<b>181</b>	<b>7</b>	<b>8</b>

*P. K. K. K.*  
T & P OFFICER

*A. S. S.*  
T & P COORDINATOR

*S. S. S.*  
PRINCIPAL

PRINCIPAL,  
K S R INSTITUTE FOR  
ENGINEERING AND TECHNOLOGY,  
K. S. P. KALYANAGAR,  
TIRUCHENGODE - 637 215,  
NAMAKKAL DISTRICT, TAMIL NADU.

Fore Noon session

S.NO	BRANCH	Non PRP			
		STRENGTH	PRESENT	ABSENT	LEAVE
1	CSE	7	6	0	1
2	ECE - A & B	41	39	0	2
3	EEE - A & B	26	24	2	0
4	IT	5	2	0	3
5	MECH A, B & C	117	107	2	8
<b>Total</b>		<b>196</b>	<b>178</b>	<b>4</b>	<b>14</b>

S.NO	BRANCH	Non PRP			
		STRENGTH	PRESENT	ABSENT	LEAVE
1	CSE	7	6	0	1
2	ECE - A & B	41	39	0	2
3	EEE - A & B	26	24	2	0
4	IT	5	2	0	3
5	MECH A, B & C	117	107	2	8
<b>Total</b>		<b>196</b>	<b>178</b>	<b>4</b>	<b>14</b>

  
T & P OFFICER

  
T & P COORDINATOR



  
PRINCIPAL

PRINCIPAL,  
K S R INSTITUTE FOR  
ENGINEERING AND TECHNOLOGY,  
K. S. R. KAM NAGAR,  
TIRUCHENGODE - 637 215,  
NAMAKKAL DS, TAMIL NADU.

Fore Noon session

S.NO	BRANCH	Non PRP			
		STRENGTH	PRESENT	ABSENT	LEAVE
1	CSE	7	7	0	0
2	ECE - A & B	41	40	1	0
3	EEE - A & B	26	26	0	0
4	IT	5	4	1	0
5	MECH A, B & C	116	107	3	6
<b>Total</b>		<b>195</b>	<b>184</b>	<b>5</b>	<b>6</b>

S.NO	BRANCH	Non PRP			
		STRENGTH	PRESENT	ABSENT	LEAVE
1	CSE	7	7	0	0
2	ECE - A & B	41	40	1	0
3	EEE - A & B	26	26	0	0
4	IT	5	4	1	0
5	MECH A, B & C	116	107	3	6
<b>Total</b>		<b>195</b>	<b>184</b>	<b>5</b>	<b>6</b>

*[Signature]*  
T & P OFFICER

*[Signature]*  
T & P COORDINATOR



*[Signature]*  
PRINCIPAL

PRINCIPAL  
K S R INSTITUTE FOR  
ENGINEERING AND TECHNOLOGY,  
K. S. R. ROAD,  
TIRUCHENGODE - 637 215,  
NAMAKKAL DISTRICT, TAMIL NADU.



## Fore Noon session

S.NO	BRANCH	Non PRP			
		STRENGTH	PRESENT	ABSENT	LEAVE
1	CSE	7	6	1	0
2	ECE - A & B	41	41	0	0
3	EEE - A & B	26	26	0	0
4	IT	5	4	0	1
5	MECH A, B & C	116	109	4	3
<b>Total</b>		<b>195</b>	<b>186</b>	<b>5</b>	<b>4</b>

S.NO	BRANCH	Non PRP			
		STRENGTH	PRESENT	ABSENT	LEAVE
1	CSE	7	6	1	0
2	ECE - A & B	41	41	0	0
3	EEE - A & B	26	26	0	0
4	IT	5	4	0	1
5	MECH A, B & C	116	109	4	3
<b>Total</b>		<b>195</b>	<b>186</b>	<b>5</b>	<b>4</b>

*[Signature]*  
T & P OFFICER

*[Signature]*  
T & P COORDINATOR

*[Signature]*  
PRINCIPAL

PRINCIPAL  
K. S. R. INSTITUTE FOR  
ENGINEERING AND TECHNOLOGY,  
K. S. L. LAKSHMI NAGAR,  
TIRUCHENGODE - 637 215,  
NANDYAL P. TALUK, MADHURAI DISTRICT.

K S R INSTITUTE FOR ENGINEERING AND TECHNOLOGY  
TIRUCHENGODE - 637 215

TRAINING PROGRAMME FEEDBACK FORM



Name of the Student: M. Sasitha Branch: ECE

Year / Sem: IV / VII

1. Name of the Training: Appitude

2. Name of the Trainer: sharmada

3. Students rating of Trainers :

S. No.	Date	Subject	Rating (√)			
			Excellent	Very good	Good	Average
1	4/8/17	probability	✓			

4. Two positive points about the programme:

The Teaching was good.

5. Suggestions for improvement:

need more problems to solved.

Date: 4/8/17

M.S.S  
Signature

K S R INSTITUTE FOR ENGINEERING AND TECHNOLOGY  
TIRUCHENGODE - 637 215

TRAINING PROGRAMME FEEDBACK FORM



Name of the Student: BARATH KUMAR. M. Branch: ECE

Year / Sem: IV / VII

1. Name of the Training: Verbal Training [verbal class]

2. Name of the Trainer: Aathish

3. Students rating of Trainers :

S. No.	Date	Subject	Rating (√)			
			Excellent	Very good	Good	Average
1	04/08/17	Sentence Correction		✓		

4. Two positive points about the programme:

1) solved more examples  
2) not clear idea about the topic

5. Suggestions for improvement:

Nil

Date: 04/08/17

K S R INSTITUTE FOR  
ENGINEERING AND TECHNOLOGY,  
K. S. R. NAGAR,  
TIRUCHENGODE - 637 215  
NAMAKKAL DISTRICT, TAMIL NADU.

M. Barath Kumar  
Signature



Name of the Student: S. Stephan Sibu

Branch: EEE

Year / Sem: IV / VII

4. Name of the Training: Verbal training

5. Name of the Trainer: Fadhrih

6. Students rating of Trainers :

S. No.	Date	Subject Verbal	Rating (√)			
			Excellent	Very good	Good	Average
1	04/05/17	Sententance Correction		✓		

4. Two positive points about the programme:

explaining clearly and it understand easily

5. Suggestions for improvement:

Better question to

Date: 04/05/17

Signature



Name of the Student: K. Sridhar

Branch: Mech

Year / Sem: IV / VII

4. Name of the Training: Sharmida

5. Name of the Trainer :

6. Students rating of Trainers :

S. No.	Date	Subject	Rating (√)			
			Excellent	Very good	Good	Average
1	4/8/17	Probability		✓		

4. Two positive points about the programme: Good knowledge

5. Suggestions for improvement:

student, need

Date: 4/8/17

More short cuts, Friendly with  
book.

K S R INSTITUTE FOR  
ENGINEERING AND TECHNOLOGY,  
K. S. R. KALAI NADAR,  
TIRUCHENGODE - 637 215,  
NAMANGALUR, TAMIL NADU.

K. Sridhar  
Signature



Name of the Student: S. LAVANYA

Branch: MECHANICAL

Year / Sem: IV / 1<sup>st</sup>

1. Name of the Training: Time + Work, probability test

2. Name of the Trainer: SINDHU

3. Students rating of Trainers :

S. No.	Date	Subject	Rating (✓)			
			Excellent	Very good	Good	Average
1	4/8/17	Time + work Test		✓		

30  
Pak - Test 1, Test 2  
Pa-kab - Test 1  
Senda - Test 1

4. Two positive points about the programme: Question paper is good.  
Time + work is better than probability.

5. Suggestions for improvement: no suggestions

Date: 4/8/17

S. S. S.  
Signature of Trainer



Name of the Student: DHANYA PRABHA P

Branch: FCE

Year / Sem: IV - 07

4. Name of the Training: online test (time & work, probability)

5. Name of the Trainer: SINDHU

6. Students rating of Trainers :

S. No.	Date	Subject	Rating (✓)			
			Excellent	Very good	Good	Average
1	A-8-17	online test (time & work, probability)		✓		

4. Two positive points about the programme: Getting practiced & (helps to solve the problems with an time)

5. Suggestions for improvement:

NO comments

Date: 4/8/17

PRINCIPAL,  
K. S. R. INSTITUTE FOR  
ENGINEERING AND TECHNOLOGY,  
K. S. R. KALVI NAGAR,  
TIRUCHENGODE - 637 215,  
NAMAKKAL DISTRICT, TAMIL NADU.

P. D. S.  
Signature

K S R INSTITUTE FOR ENGINEERING AND TECHNOLOGY  
TIRUCHENGODE - 637 215



TRAINING PROGRAMME FEEDBACK FORM

Name of the Student: R. V. Rishikash Branch: ECF

Year / Sem: 04/07

1. Name of the Training: Probability & Time work, Verbal

2. Name of the Trainer: Sharmila, Aadhi

3. Students rating of Trainers :

S. No.	Date	Subject	Rating (✓)			
			Excellent	Very good	Good	Average
1	4/8/17	Probability	✓			

4. Two positive points about the programme: Clarity in teaching & delivered lot of contents & voice is audible.

5. Suggestions for improvement: Solve only tough problems.

Rishikash  
Signature

Date: 4/8/17

K S R INSTITUTE FOR ENGINEERING AND TECHNOLOGY  
TIRUCHENGODE - 637 215



TRAINING PROGRAMME FEEDBACK FORM

Name of the Student: S. Surya Branch: EEE

Year / Sem: IV/VII

4. Name of the Training: (Probability & Time, work, Verbal) Test

5. Name of the Trainer: Aadhi

6. Students rating of Trainers :

S. No.	Date	Subject	Rating (✓)			
			Excellent	Very good	Good	Average
1	4/8/17	Probability Verbal		✓		

4. Two positive points about the programme:

\* clarity in teaching

\* lot of basics

5. Suggestions for improvement:

Solve the only tough

problems  
PRINCIPAL,  
K. S. R. INSTITUTE FOR  
ENGINEERING AND TECHNOLOGY,  
K. S. R. WALVI NAGAR,  
TIRUCHENGODE - 637 215,  
NAMAKKAL DI, TAMIL NADU.

S. Surya  
Signature

Date:

4/8/2017

Surya

K S R INSTITUTE FOR ENGINEERING AND TECHNOLOGY  
TIRUCHENGODE - 637 215

TRAINING PROGRAMME FEEDBACK FORM



Name of the Student: S. SABARINATHAN

Branch: CSE

Year / Sem: IV / VII

1. Name of the Training : QUANTITATIVE & VERBAL

2. Name of the Trainer :

3. Students rating of Trainers : 8/10

S. No.	Date	Subject	Rating (√)			
			Excellent	Very good	Good	Average
1	4.08.17	SENTENCE CORRECTION READING COMPREHENSION		✓		

4. Two positive points about the programme:

He Explain with Example

So, The class is very easy to learn.

5. Suggestions for improvement:

NONE

Date: 4/8/17

*[Signature]*

Signature

K S R INSTITUTE FOR ENGINEERING AND TECHNOLOGY  
TIRUCHENGODE - 637 215

TRAINING PROGRAMME FEEDBACK FORM



Name of the Student: R. Selvaganapathi

Branch: CSE

Year / Sem: IV / VII

4. Name of the Training : Quantitative & Verbal

5. Name of the Trainer : S. HARMILA

6. Students rating of Trainers : 7/10

S. No.	Date	Subject	Rating (√)			
			Excellent	Very good	Good	Average
1	4.8.17	Probability time & work		✓		

4. Two positive points about the programme:

This class is very nice

Easy way to understand the problem

5. Suggestions for improvement:

Need to tell detail about  
the concepts

Date: 4/8/17

*[Signature]*

Signature

K S R INSTITUTE FOR ENGINEERING AND TECHNOLOGY  
TIRUCHENGODE - 637 215

TRAINING PROGRAMME FEEDBACK FORM



Name of the Student: L. Crook Parasath

Branch: Mechanical

Year / Sem: IV / Seven

1. Name of the Training: Aptitude

2. Name of the Trainer: Sharmila

3. Students rating of Trainers :

S. No.	Date	Subject	Rating (✓)			
			Excellent	Very good	Good	Average
1	4/8/17	Time & work probability	✓			

4. Two positive points about the programme:

Teaching was good. Short cuts were taught easily

5. Suggestions for improvement:

Nothing

[Signature]  
Signature

Date: 4/08/2017

K S R INSTITUTE FOR ENGINEERING AND TECHNOLOGY  
TIRUCHENGODE - 637 215

TRAINING PROGRAMME FEEDBACK FORM



Name of the Student: K. HARIHARAN

Branch: MECHANICAL

Year / Sem: IX / VII

4. Name of the Training: Verbal

5. Name of the Trainer :

6. Students rating of Trainers :

S. No.	Date	Subject	Rating (✓)			
			Excellent	Very good	Good	Average
1	4.8.2017	Sentence construction / Reading comprehension		✓		

4. Two positive points about the programme:

⇒ Method of approach is good.  
⇒ Fluency is good.

5. Suggestions for improvement:

Nothing

Date: 4.8.2017

PRINCIPAL,  
K S R INSTITUTE FOR  
ENGINEERING AND TECHNOLOGY,  
K. S. R. KALVI NAGAR,  
TIRUCHENGODE - 637 215,  
NAMAKKAL DL, TAMIL NADU.

[Signature]  
Signature

**K S R INSTITUTE FOR ENGINEERING AND TECHNOLOGY**  
**TIRUCHENGODE - 637 215** Theory  
**TRAINING PROGRAMME FEEDBACK FORM -Lab Session**

Name of the Student: MADHAN.V

Date: 5/8/17

Branch: EEE

Year / Sem: Final / 07

1. Name of the Training : VERBAL , APTITUDE

2. Name of the Trainer :

3. Test Topic Details :

S. No.	Test Topic Discussed	Test Name	Discussed Topic suggestions
1.	Tumbled Sentence		Nil
2.	Sequence & Series		More examples needed

4. Suggestions for improvement:

*[Signature]*  
Signature

**K S R INSTITUTE FOR ENGINEERING AND TECHNOLOGY**  
**TIRUCHENGODE - 637 215** Theory  
**TRAINING PROGRAMME FEEDBACK FORM -Lab Session**

Name of the Student: mahendran . A

Date: 5/8/17

Branch: MECH

Year / Sem: IV / 7

1. Name of the Training : verbal

2. Name of the Trainer : Aadhi

3. Test Topic Details : -

S. No.	Test Topic TOPICS Discussed	Test Name	Discussed Topic suggestions
1	Paragraph formation		-
2	Theme detection		-

4. Suggestions for improvement: Don't make verbal classes after lunch it make too tired

*[Signature]*  
Signature



**K S R INSTITUTE FOR ENGINEERING AND TECHNOLOGY  
TIRUCHENGODE - 637 215  
TRAINING PROGRAMME FEEDBACK FORM - Lab Session**

Name of the Student: S. Ranjith Kumar

Date: 5-08-17

Branch: B.E Mechanical Engineering

Year / Sem: IV / 07

1. Name of the Training : Suriya ( Placement Training )

2. Name of the Trainer : Gharmi

3. Test Topic Details :

S. No.	Test Topic	Test Name	Discussed Topic
1	Percentage [APPTUDE]	Percentage	Percentage
2	Theme detection [VERBAL]	Theme detection	Theme detection
3	Jumbled sentences [VERBAL]	Sequence and series	Jumbled sentences

4. Suggestions for improvement:

*To explain more questions.*   
Signature

**K S R INSTITUTE FOR ENGINEERING AND TECHNOLOGY  
TIRUCHENGODE - 637 215  
TRAINING PROGRAMME FEEDBACK FORM - Lab Session**

Name of the Student: S. MOHAN

Date: 5/8/17

Branch: MECH

Year / Sem: IV / VII

1. Name of the Training : APTITUDE (VERBAL)

2. Name of the Trainer : SINDHU

3. Test Topic Details :

S. No.	Test Topic	Test Name	Discussed Topic
1	PERCENTAGES	TEST 1	Problem based on Percentages
2	SEQUENCE & SERIES	TEST 1	Problem on logical devices
3	THEME DETECTION	TEST 1	
4	BLOOD RELATION		Examples for blood relation

4. Suggestions for improvement:

  
PRINCIPAL,  
K. S. R. INSTITUTE FOR  
ENGINEERING AND TECHNOLOGY,  
K. S. R. MAIN ROAD,  
TIRUCHENGODE - 637 215,  
TAMIL NADU.

  
Signature

**K S R INSTITUTE FOR ENGINEERING AND TECHNOLOGY**  
**TIRUCHENGODE - 637 215**  
**TRAINING PROGRAMME FEEDBACK FORM - Lab Session**

Name of the Student: K. Deepan

Date: 5-08-17

Branch: BE Electronics & communication Engineering Year / Sem: IV / 07

1. Name of the Training: Jwiyg (Placement Training)

2. Name of the Trainer: Sharmi

3. Test Topic Details :

S. No.	Test Topic	Test Name	Discussed Topic
1.	Percentage [APTITUDE]	Percentage	Percentage
2.	VERBAL	Theme detection	Theme detection
3.	VERBAL (Jumbled sentence)	Sequence and series	Jumbled sentences

4. Suggestions for improvement:

\* need for clear explanation  
 \* And give more examples

[Signature]  
Signature

Name of the Student: Prasanth

Branch: Mechanical Engineering

Year / Sem: Final year / 07

1. Name of the Training: Sequence Series, Percentages

2. Name of the Trainer: Sasmita

3. Students rating of Trainers :

S. No.	Date	Subject	Rating (✓)			
			Excellent	Very good	Good	Average
1	5-8-17	Percentages Sequence & Series			✓	

4. Two positive points about the programme:

Best explanation with examples  
 For will be strong in APPS

Percentages - 8

Sequence Series - 8

5. Suggestions for improvement:

TO impressive talking

Date: 5-8-17

K S R INSTITUTE FOR  
 ENGINEERING AND TECHNOLOGY,  
 K. S. P. RAJAN NAGAR,  
 TIRUCHENGODE - 637 215,  
 NARANKULU, 24, PAKKAL NADU.

[Signature]  
Signature

**K S R INSTITUTE FOR ENGINEERING AND TECHNOLOGY**  
**TIRUCHENGODE - 637 215** Theory  
**TRAINING PROGRAMME FEEDBACK FORM -Lab Session**

Name of the Student: MADHAN V

Date: 5/8/17

Branch: EEE

Year / Sem: Final / 07

1. Name of the Training : VERBAL , APTITUDE

2. Name of the Trainer :

3. Test Topic Details :

S. No.	Test Topic discussed	Test Name	Discussed Topic suggestions
1.	Tumbled Sentence		Nil
2.	Sequence & Series		More examples needed

4. Suggestions for improvement:

  
Signature

**K S R INSTITUTE FOR ENGINEERING AND TECHNOLOGY**  
**TIRUCHENGODE - 637 215** Theory  
**TRAINING PROGRAMME FEEDBACK FORM -Lab Session**

Name of the Student: mahendran . A

Date: 5/8/17

Branch: MECH

Year / Sem: IV / 7

1. Name of the Training : verbal

2. Name of the Trainer : Adhi

3. Test Topic Details : -

S. No.	Test Topic discussed	Test Name	Discussed Topic suggestions
1	Paragraph formation		-
2	Theme detection		-

4. Suggestions for improvement: Donot make global classes after lunch it make too tide

  
Signature

PRINCIPAL,  
**K S R INSTITUTE FOR**  
**ENGINEERING AND TECHNOLOGY,**  
**M. S. R. KALVI NAGAR,**  
**TIRUCHENGODE - 637 215,**  
**NAMAKKAL, TAMIL NADU.**

**K S R INSTITUTE FOR ENGINEERING AND TECHNOLOGY  
TIRUCHENGODE - 637 215  
TRAINING PROGRAMME FEEDBACK FORM - Lab Session**

Name of the Student: S. Ranjith Kumar

Date: 5-08-17

Branch: B.E Mechanical Engineering

Year / Sem: IV / 07

1. Name of the Training: Sunija (Placement Training)

2. Name of the Trainer: Sharmi

3. Test Topic Details :

S. No.	Test Topic	Test Name	Discussed Topic
1	Percentage [APPETUDE]	Percentage	Percentage
2	Theme detection [VERBAL]	Theme detection	Theme detection
3	Jumbled sentences [VERBAL]	Sequence and Series	Jumbled sentences

4. Suggestions for improvement:

*To explain more questions.*   
Signature

**K S R INSTITUTE FOR ENGINEERING AND TECHNOLOGY  
TIRUCHENGODE - 637 215  
TRAINING PROGRAMME FEEDBACK FORM - Lab Session**

Name of the Student: S. MOHAN

Date: 5/8/17

Branch: MECH

Year / Sem: IV / VII

1. Name of the Training: APTITUDE (VERBAL)

2. Name of the Trainer: SINDHU

3. Test Topic Details :

S. No.	Test Topic	Test Name	Discussed Topic
1	PERCENTAGES	TEST 1	Problem based on Percentages
2	SEQUENCE & SERIES	TEST 1	Problem on logical devices
3	THEME DETECTION	TEST 1	
4	BLOOD RELATION		Examples for blood relation

4. Suggestions for improvement:

  
Signature

  
PRINCIPAL,  
K. S. R. INSTITUTE FOR  
ENGINEERING AND TECHNOLOGY,  
K. S. R. KALVINAGAR,  
TIRUCHENGODE - 637 215,  
NAMAKKAL DISTRICT, TAMIL NADU.

Name of the Student: K. Prithvi

Date: 05/08/17

Branch: Mechanical

Year / Sem: V / 7

1. Name of the Training: Blood relation, Syllogism

2. Name of the Trainer: Sindhu

3. Test Topic Details :

S. No.	Test Topic	Test Name	Discussed Topic
1	Verbal	Entire Cassation	Syllogism
2	Quantitative	Time & work	

4. Suggestions for improvement:

\* Good knowledge for

[Signature]  
Signature

Short cuts Needed

\* Need of hour lunch break



Name of the Student: P. Suresh

Branch: Mechanical

Year / Sem: VII / IV-year

1. Name of the Training: Shoreline - Six phrases

2. Name of the Trainer: Sharmila

3. Students rating of Trainers :

S. No.	Date	Subject	Rating (✓)			
			Excellent	Very good	Good	Average
1	5.8.17	Aptitude. Verbal			✓	

Aptitude - percentage (sum) - 7.

4. Two positive points about the programme:

Explained clearly.

Sums has worked

in class many and clearly.

Sequence & series (sum) - 10,  
chain Rule -

5. Suggestions for improvement:

Loud voice.

Date: 5.8.17

More shortcut method

Sum and topics

Signature: P. Suresh

K S R INSTITUTE FOR ENGINEERING AND TECHNOLOGY  
TIRUCHENGODE - 637 215

TRAINING PROGRAMME FEEDBACK FORM



Name of the Student: N. Sineha

Branch: ECE

Year / Sem: IV - VII

1. Name of the Training: Verbal

2. Name of the Trainer: Aadhi

3. Students rating of Trainers:

S. No.	Date	Subject	Rating (✓)			
			Excellent	Very good	Good	Average
1	5-8-17	Jumbled sentence, Theme detection		✓		

4. Two positive points about the programme:

Explain the topic very clearly, and he told many practical example.

5. Suggestions for improvement:

Nil

Date: 5-8-2017

N. Sineha  
Signature

K S R INSTITUTE FOR ENGINEERING AND TECHNOLOGY  
TIRUCHENGODE - 637 215

TRAINING PROGRAMME FEEDBACK FORM



Name of the Student: A. Nivetha

Branch: ECE

Year / Sem: IV - VI

4. Name of the Training: Quantitative

5. Name of the Trainer:

6. Students rating of Trainers: M. Sharmila

S. No.	Date	Subject	Rating (✓)			
			Excellent	Very good	Good	Average
1	5-8-17	Percentages Sequence & Series		✓		

4. Two positive points about the programme:

She give many shortcuts to solve the problem.

5. Suggestions for improvement:

- Nil -

Date: 5-8-17

PRINCIPAL,  
K. S. R. INSTITUTE FOR  
ENGINEERING AND TECHNOLOGY,  
K. S. R. KALVI NAGAR,  
TIRUCHENGODE - 637 215,  
NAMAKKAL Dt, TAMIL NADU.

A. Nivetha  
Signature

**K S R INSTITUTE FOR ENGINEERING AND TECHNOLOGY**  
**TIRUCHENGODE - 637 215**  
**TRAINING PROGRAMME FEEDBACK FORM - Lab Session**

Name of the Student: ~~Sindhya~~ Divya-s

Date: 5/8/17

Branch: ECE

Year / Sem: IV / VII

1. Name of the Training : Aptitude.

2. Name of the Trainer : Sindhya.

3. Test Topic Details :

S. No.	Test Topic	Test Name	Discussed Topic
1.	Percentages	Test 1	difficult problems percentage based
2.	Sequence & series	Test 1	Difficult logical series
3.	Theme detection	Test 1	
4.	Blood Relations		Examples based on blood relations.

4. Suggestions for improvement: we need more time to solve the Quantitative aptitude questions.

S. Divya  
Signature

**K S R INSTITUTE FOR ENGINEERING AND TECHNOLOGY**  
**TIRUCHENGODE - 637 215**  
**TRAINING PROGRAMME FEEDBACK FORM - Lab Session**

Name of the Student: S. DURKADEVI

Date: 05.08.17.

Branch: ECE.

Year / Sem: IV / VII.

1. Name of the Training :

2. Name of the Trainer : Sindhya

3. Test Topic Details :

S. No.	Test Topic	Test Name	Discussed Topic
1.	Verbal	Reading comprehension Sentence completion	Blood relation
2.	quantitative	Time and Work	

4. Suggestions for improvement: Discussion can be done more sufficient

S. Durka Devi  
Signature

PRINCIPAL,  
**K. S. R. INSTITUTE FOR  
 ENGINEERING AND TECHNOLOGY,**  
 K. S. P. KALVINAGAR,  
 TIRUCHENGODE - 637 215,  
 NAMAKKAL DISTRICT, TAMIL NADU.

TRAINING PROGRAMME FEEDBACK FORM

Name of the Student: Atchaya R.

Branch: BE-ECE

Year / Sem: IV / VII

1. Name of the Training: Aptitude

2. Name of the Trainer: Giomathi, sharmila

3. Students rating of Trainers: L

S. No.	Date	Subject	Rating (√)			
			Excellent	Very good	Good	Average
1	7.08.2017	Time, speed, distance		✓		

4. Two positive points about the programme:

↳ Can understand well.

↳ Giving more explanations

5. Suggestions for improvement:

Time allotment can be increased for every sessions.

Date: 07.08.2017

Signature Atchaya R.

TRAINING PROGRAMME FEEDBACK FORM

Name of the Student: NT Nandhini

Branch: BE | ECE

Year / Sem: IV / 07

4. Name of the Training: Aptitude

5. Name of the Trainer: Giomathi, sharmila

6. Students rating of Trainers:

S. No.	Date	Subject	Rating (√)			
			Excellent	Very good	Good	Average
1	07/08/17	Time, speed, distance		✓		

4. Two positive points about the programme:

The class was well. We understood that topics.

5. Suggestions for improvement:

→ To solve more problems for every sessions.

→ We need more time to solve problems.

Date: 07/08/17

Signature

NT Nandhini  
07/08/17



**K S R INSTITUTE FOR ENGINEERING AND TECHNOLOGY**  
**TIRUCHENGODE - 637 215**  
**TRAINING PROGRAMME FEEDBACK FORM - Lab Session**

Name of the Student: S. Prasadhaasini

Date: 7/8/17

Branch:

Year / Sem: IV / VII

1. Name of the Training : Six phase -

2. Name of the Trainer :

3. Test Topic Details :

S. No.	Test Topic	Test Name	Discussed Topic
1.	Time, distance & speed	Quantitative.	Time, distance
2.	sentence selection	verbal test.	Speed and
3.	Direction test	<del>Verbal</del> Reasoning level	sentence selection
			Directions -

4. Suggestions for improvement: Nil.

  
Signature

**K S R INSTITUTE FOR ENGINEERING AND TECHNOLOGY**  
**TIRUCHENGODE - 637 215**  
**TRAINING PROGRAMME FEEDBACK FORM - Lab Session**

Name of the Student: V. Nagesha Narayan Kumar

Date: 7-8-17

Branch:

Year / Sem: IV / VII

1. Name of the Training : Six phase

2. Name of the Trainer :

3. Test Topic Details :

S. No.	Test Topic	Test Name	Discussed Topic
1.	Verbal Analogy Sentence Selection	Verbal Aptitude	Sentence Selection by grammar
2.	Time, Speed & distance	Quantitative Aptitude	Speed, Distance
3.	Time, speed & distance	- test (AN)	time in boats,
4.	Sentence Selection, Direction, Verbal Analogy		train ...

4. Suggestions for improvement: Nil

  
Signature

PRINCIPAL,  
**K. S. R. INSTITUTE FOR  
 ENGINEERING AND TECHNOLOGY,**  
 K. S. R. NAGAR,  
 TIRUCHENGODE - 637 215,  
 NAMAKKAL DISTRICT, TAMIL NADU.

**K S R INSTITUTE FOR ENGINEERING AND TECHNOLOGY**  
**TIRUCHENGODE - 637 215**  
**TRAINING PROGRAMME FEEDBACK FORM - Lab Session**

Name of the Student: DHIVANAR. A

Date: 7/8/17

Branch:

Year / Sem: IV - V

1. Name of the Training : Percentage

2. Name of the Trainer : Gomathi

3. Test Topic Details : Logical order, Reasoning, Quantitative.

S. No.	Test Topic	Test Name	Discussed Topic
1	logical order	-	-
2	sentence completion	-	-

4. Suggestions for improvement:

Compare to last week today is better

A. Dhivana  
Signature 7/8/17

**K S R INSTITUTE FOR ENGINEERING AND TECHNOLOGY**  
**TIRUCHENGODE - 637 215**  
**TRAINING PROGRAMME FEEDBACK FORM - Lab Session**

Name of the Student: G. Saravana Abishan.

Date: 7/8/17

Branch: CSIE

Year / Sem: IV (V)

1. Name of the Training : Verbal

2. Name of the Trainer : Gomathi.

3. Test Topic Details : Logical order, Sentence Correction.

S. No.	Test Topic	Test Name	Discussed Topic
1)	logical order		
2)	Sentence correction		

4. Suggestions for improvement:

Teach some extra concepts.

G. Saravana  
Signature



Name of the Student: R. Selwaganesathi

Branch: CSE

Year / Sem: IV / VII

1. Name of the Training: Quantitative

2. Name of the Trainer: Sharmila

3. Students rating of Trainers: 7/10

S. No.	Date	Subject	Rating (✓)			
			Excellent	Very good	Good	Average
1	7.8.16	Time, Speed & Distance			✓	

4. Two positive points about the programme:

Class is very nice  
Teaching method is very friendly

5. Suggestions for improvement:

Teach more concept for  
the specific topic  
Please keep the timing

Date: 7.8.16

R. Selwaganesathi  
Signature



Name of the Student: C. Soundarabharathi

Branch: EEE

Year / Sem: IV / VII

4. Name of the Training: Verbal aptitude

5. Name of the Trainer: Mr. Aadhi

6. Students rating of Trainers: 9/10

S. No.	Date	Subject	Rating (✓)			
			Excellent	Very good	Good	Average
1	7/8/16	Sentence Completion, Selection of words		✓		

4. Two positive points about the programme:

\* Interaction with students is good compare others.  
\* And he explained that topic with live examples.

5. Suggestions for improvement:

\* Teaching, Explaining all are good. No more  
Chances

Date: 7/8/16 (AN)

C. Soundarabharathi  
Signature  
K. S. R. INSTITUTE FOR  
ENGINEERING AND TECHNOLOGY,  
K. S. R. KALAI NAGAR,  
TIRUCHENGODE - 637 215,  
TAMIL NADU.

TRAINING PROGRAMME FEEDBACK FORM

Name of the Student: M. Jyothul raj

Branch: Mechanical

Year / Sem: IV / 107<sup>th</sup>

Engineering

1. Name of the Training: Six phase

2. Name of the Trainer: Charmila

3. Students rating of Trainers :

S. No.	Date	Subject	Rating (✓)			
			Excellent	Very good	Good	Average
1	7/8/17	Time, speed & distance		✓		

4. Two positive points about the programme:

a) clearing doubts & easily understood

5. Suggestions for improvement: b) understand to solve problem in limited time

a) Increase Topic coverage

no. of questions  
taught = 15

Date: 7/8/17

Signature

M. Jyothul raj

TRAINING PROGRAMME FEEDBACK FORM

Name of the Student: K. NIVASAN

Branch: BE / Mechanical

Year / Sem: IV / VII

4. Name of the Training: Six Phase

5. Name of the Trainer: Aadhi

6. Students rating of Trainers :

S. No.	Date	Subject	Rating (✓)			
			Excellent	Very good	Good	Average
1	7.8.17	Sentence Selection	✓			

No. of questions: 20.

4. Two positive points about the programme: i) More no. of examples.

ii) More lively teaching.

5. Suggestions for improvement: We want the same trainer for Soft skills Development, especially Aadhi Sir.

Date: 7.8.17

Signature  
K. Princy  
K. S. R. INSTITUTE FOR  
ENGINEERING AND TECHNOLOGY  
K. S. P. KALYANAGAR,  
TIRUCHENGODE - 637 215,  
NARAYANAPURAM, TAMIL NADU.

**K S R INSTITUTE FOR ENGINEERING AND TECHNOLOGY**  
**TIRUCHENGODE - 637 215**  
**TRAINING PROGRAMME FEEDBACK FORM - Lab Session**

Name of the Student: S. Sam prakash

Date: 7.8.17

Branch: Mechanical

Year / Sem: IV / 7

1. Name of the Training: Placement Aptitude

2. Name of the Trainer: Sindhu

3. Test Topic Details :

S. No.	Test Topic	Test Name	Discussed Topic
1.	Blood Relations	-	Blood Relations.
2.	Percentage	Test - 1	Percentage

4. Suggestions for improvement:

We are expecting more different questions

  
Signature

**K S R INSTITUTE FOR ENGINEERING AND TECHNOLOGY**  
**TIRUCHENGODE - 637 215**  
**TRAINING PROGRAMME FEEDBACK FORM - Lab Session**

Name of the Student: K. Raghav Kumar

Date: 9/8/17

Branch: Mechanical

Year / Sem: IV / 7

1. Name of the Training: Aptitude

2. Name of the Trainer: Sindhu

3. Test Topic Details :

S. No.	Test Topic	Test Name	Discussed Topic
1.	Percentages	Test - 1	Percentages
2.	Sequences & series	Test 1	
3.	Time detection	Test 1	

4. Suggestions for improvement:

more short cut methods we need

  
Signature

PRINCIPAL,  
**K. S. R. INSTITUTE FOR ENGINEERING AND TECHNOLOGY,**  
**K. S. P. KALYANAGAR,**  
**TIRUCHENGODE - 637 215,**  
**NAMAKKAL Dt, TAMIL NADU.**

**K S R INSTITUTE FOR ENGINEERING AND TECHNOLOGY  
TIRUCHENGODE - 637 215**



**TRAINING PROGRAMME FEEDBACK FORM**

Name of the Student: M. Velmarigan

Branch: Mechanical Engineering

Year / Sem: IV / VII

1. Name of the Training : Sharmila Time / speed / distances

2. Name of the Trainer : Sharmila

3. Students rating of Trainers :

S. No.	Date	Subject	Rating (√)			
			Excellent	Very good	Good	Average
1	7/8/17	Apitute		✓		

4. Two positive points about the programme:

\* Explanation is good

\* Easy to understand all concepts

5. Suggestions for improvement:

\* different type of problems to solve

Date: 07/08/17

M. S. Pulay...  
Signature

**K S R INSTITUTE FOR ENGINEERING AND TECHNOLOGY  
TIRUCHENGODE - 637 215**



**TRAINING PROGRAMME FEEDBACK FORM**

Name of the Student: R. Dhayarithu

Branch: B.E. MECHANICAL ENGG

Year / Sem: IV / VII

4. Name of the Training : sequence pattern

5. Name of the Trainer :

6. Students rating of Trainers :

S. No.	Date	Subject	Rating (√)			
			Excellent	Very good	Good	Average
1	7.8.17.	Verbal.	✓			

4. Two positive points about the programme:

\* Explanation is very good.

\* Easy to learn.

5. Suggestions for improvement:

Date: 0.7.8.17

PRINCIPAL,  
K S R INSTITUTE FOR  
ENGINEERING AND TECHNOLOGY,  
K. S. P. K. V. P. NAGAR,  
TIRUCHENGODE - 637 215,  
NAMAKAL DI, TAMIL NADU.

R. [Signature]  
Signature

**K S R INSTITUTE FOR ENGINEERING AND TECHNOLOGY**  
**TIRUCHENGODE - 637 215**  
**TRAINING PROGRAMME FEEDBACK FORM - Lab Session**

Name of the Student: S. Nainar Mohamed

Date: 07/08/17

Branch: Mechanical Engineering

Year / Sem: IV / B

1. Name of the Training : Sindhu

2. Name of the Trainer :

3. Test Topic Details :

S. No.	Test Topic	Test Name	Discussed Topic
1.	Sentence Selection	Sentence selection	
2.	Quantitative	Time, Distance, Speed	Time, Distance, Speed
3.	Verbal.	Verbal analogies	

4. Suggestions for improvement:

Nil

  
 Signature

**K S R INSTITUTE FOR ENGINEERING AND TECHNOLOGY**  
**TIRUCHENGODE - 637 215**  
**TRAINING PROGRAMME FEEDBACK FORM - Lab Session**

Name of the Student: Mudaliyar Vishnu Parasuraman

Date: 07/08/17

Branch: Mechanical Engineering

Year / Sem: IV / C

1. Name of the Training : Sindhu

2. Name of the Trainer :

3. Test Topic Details :

S. No.	Test Topic	Test Name	Discussed Topic
1.	verbal	verbal analogies	
2.	Quantitative	Time, Distance, Speed	Time, Distance, Speed
3.	Sentence Selection	Sentence Selection	

4. Suggestions for improvement:

Nil

  
 Signature

  
 PRINCIPAL,  
 K. S. R. INSTITUTE FOR  
 ENGINEERING AND TECHNOLOGY,  
 K. S. P. KALVI NAGAR,  
 TIRUCHENGODE - 637 215,  
 NAMANGAL DT, TAMIL NADU.

**K S R INSTITUTE FOR ENGINEERING AND TECHNOLOGY**  
**TIRUCHENGODE - 637 215**  
**TRAINING PROGRAMME FEEDBACK FORM - Lab Session**

Name of the Student: R. vijay

Date: 8.8.2017

Branch: EEE

Year / Sem: IV - 7 sem

1. Name of the Training : Verbal Analogies - Reading Comprehension.

2. Name of the Trainer : Aadhi.

3. Test Topic Details :

S. No.	Test Topic	Test Name	Discussed Topic
1.	<u>Sentence Formation</u>	<u>Sentence Formation</u>	<u>Arrangement order</u>
2.	<u>Calender.</u>	<u>calender</u>	<u>Find the date, year.</u>

4. Suggestions for improvement:

try to give more examples.

R. vijay  
Signature

**K S R INSTITUTE FOR ENGINEERING AND TECHNOLOGY**  
**TIRUCHENGODE - 637 215**  
**TRAINING PROGRAMME FEEDBACK FORM - Lab Session**

Name of the Student: S. Surya

Date: 8/8/2017

Branch: EEE

Year / Sem: IV - 7 sem

1. Name of the Training : Distance speed & Time

2. Name of the Trainer : Sharmila

3. Test Topic Details :

S. No.	Test Topic	Test Name	Discussed Topic
1.	<u>Distance - speed &amp; Time</u>	<u>Distance - speed &amp; Time</u>	<u>Distance - speed &amp; Time</u>
2.	<u>Sentence - selection</u>	<u>sentence - selection</u>	<u>sentence - selection</u>

4. Suggestions for improvement:

\* Try to give more examples.

\* using PPT.

S. Surya  
Signature

PRINCIPAL,  
**K. S. R. INSTITUTE FOR**  
**ENGINEERING AND TECHNOLOGY,**  
**K. S. R. KALAI NAGAR,**  
**TIRUCHENGODE - 637 215,**  
**NAMAKKAL DISTRICT, TAMIL NADU.**





Name of the Student: S. Divya

Branch: BE-ECE

Year / Sem: V / VII

1. Name of the Training : Aptitude (verbal).

2. Name of the Trainer : Aadhi.

3. Students rating of Trainers :

S. No.	Date	Subject	Rating (√)			
			Excellent	Very good	Good	Average
1	8/8/17	sentence improve -ment	✓			

4. Two positive points about the programme: clear Grammatical Explanation.  
and It was not boring.

5. Suggestions for improvement: No suggestions.

Date: 8/8/17

S. Divya  
Signature



Name of the Student: Atchaya R

Branch: BE-ECE

Year / Sem: V / VII

4. Name of the Training : Aptitude (Reasoning)

5. Name of the Trainer : Sharmila

6. Students rating of Trainers :

S. No.	Date	Subject	Rating (√)			
			Excellent	Very good	Good	Average
1	8/8/17	Reasoning	✓			

4. Two positive points about the programme: clear explanations of all doubts  
↳ class was interesting

5. Suggestions for improvement:

No suggestions

Date: 8/8/17

PRINCIPAL,  
K. S. R. INSTITUTE FOR  
ENGINEERING AND TECHNOLOGY  
K. S. R. KALVIHICAR,  
TIRUCHENGODE - 637 215,  
NAMAKKAL Dt, TAMIL NADU.

R. Aadhi  
Signature

**K S R INSTITUTE FOR ENGINEERING AND TECHNOLOGY  
TIRUCHENGODE - 637 215**

**TRAINING PROGRAMME FEEDBACK FORM**



Name of the Student: T. Nandhini

Branch: EEE

Year / Sem: IV / VII

1. Name of the Training : Six phase

2. Name of the Trainer : Aadhi

3. Students rating of Trainers :

S. No.	Date	Subject	Rating (✓)			
			Excellent	Very good	Good	Average
1	08.08.2017	Verbal		✓		

4. Two positive points about the programme:

*Learned new logic, easy to solving problems.*

5. Suggestions for improvement:

-

Date: 08.08.2017

*T. Nandhini*  
Signature

**K S R INSTITUTE FOR ENGINEERING AND TECHNOLOGY  
TIRUCHENGODE - 637 215**

**TRAINING PROGRAMME FEEDBACK FORM**



Name of the Student: B. Praveenkumar

Branch: EEE-B

Year / Sem: IV / VII

4. Name of the Training : Six phase

5. Name of the Trainer : Shaxmila

6. Students rating of Trainers :

S. No.	Date	Subject	Rating (✓)			
			Excellent	Very good	Good	Average
1	8-8-17	Reasoning		✓		

4. Two positive points about the programme:

*Solved puzzles oriented questions.*

5. Suggestions for improvement:

*Time extending*

Date: 8.8.17

  
 PRINCIPAL,  
 K. S. R. INSTITUTE FOR  
 ENGINEERING AND TECHNOLOGY,  
 K. S. R. KALVI NAGAR,  
 TIRUCHENGODE - 637 215,  
 NAMAKKAL DL, TAMIL NADU.

*B. Praveen*  
Signature

Batch - 1 - Mech - FN

K S R INSTITUTE FOR ENGINEERING AND TECHNOLOGY  
TIRUCHENGODE - 637 215

TRAINING PROGRAMME FEEDBACK FORM



Name of the Student: S. Nainas Mohamed

Branch: Mechanical Engineering

Year / Sem: IV / VII

1. Name of the Training: Sharmila

2. Name of the Trainer: Surya

3. Students rating of Trainers :

S. No.	Date	Subject	Rating (✓)			
			Excellent	Very good	Good	Average
1	08/08/17	Puzzles, Sentence formations, Alternative	✓			

4. Two positive points about the programme: Explanation of the grammar is good  
Practical Understand on concept

5. Suggestions for improvement: Nil.

Date: 08/08/17

Sharma  
Signature

K S R INSTITUTE FOR ENGINEERING AND TECHNOLOGY  
TIRUCHENGODE - 637 215

TRAINING PROGRAMME FEEDBACK FORM



Name of the Student: S. Vijay

Branch: Mechanical

Year / Sem: IV / VII

4. Name of the Training: Verbal

5. Name of the Trainer: Surya Adithya

6. Students rating of Trainers :

S. No.	Date	Subject	Rating (✓)			
			Excellent	Very good	Good	Average
1	08/08/17	Calendar, sentence correction			✓	

4. Two positive points about the programme: The easy

explained - in questions

5. Suggestions for improvement:

Date: 8/8/17

PRINCIPAL,  
K. S. R. INSTITUTE FOR  
ENGINEERING AND TECHNOLOGY,  
K. S. R. KALVI NAGAR,  
TIRUCHENGODE - 637 215,  
NARANKAL RD, TAMIL NADU.

S. Vijay  
Signature

**K S R INSTITUTE FOR ENGINEERING AND TECHNOLOGY**  
**TIRUCHENGODE - 637 215**  
**TRAINING PROGRAMME FEEDBACK FORM - Lab Session**

Name of the Student: S. Aravindharaj

Date: 8.8.2017

Branch:

Year / Sem: IV / VII

1. Name of the Training : Reasoning & Verbal.

2. Name of the Trainer : Sindhu

3. Test Topic Details :

S. No.	Test Topic	Test Name	Discussed Topic
1.	Quantitative Aptitude	Analogies	Analogies.
2.	Quantitative Aptitude	Puzzles	Puzzles

4. Suggestions for improvement:

  
Signature

**K S R INSTITUTE FOR ENGINEERING AND TECHNOLOGY**  
**TIRUCHENGODE - 637 215**  
**TRAINING PROGRAMME FEEDBACK FORM - Lab Session**

Name of the Student: V. Kamala Kannan

Date: 08.08.2017

Branch:

Year / Sem: IV / VII

1. Name of the Training : Reasoning & Verbal

2. Name of the Trainer : Sindhu

3. Test Topic Details :

S. No.	Test Topic	Test Name	Discussed Topic
1.	Quantitative Aptitude	Analogies	Analogy
2.	Quantitative Aptitude	Puzzles	Puzzles
3.			

4. Suggestions for improvement:

  
Signature

PRINCIPAL,  
 K. S. R. INSTITUTE FOR  
 ENGINEERING AND TECHNOLOGY,  
 K. S. R. KALVIYALAN,  
 TIRUCHENGODE - 637 215,  
 NAMAKKAL DISTRICT, TAMIL NADU.

TRAINING PROGRAMME FEEDBACK FORM

Batch-2 - 2A N

Name of the Student: M. Ranjith Kumar

Branch: Mechanical - IV - B

Year / Sem: IV / 07

1. Name of the Training : Quantitative

2. Name of the Trainer : Sharmila

3. Students rating of Trainers :

S. No.	Date	Subject	Rating (√)			
			Excellent	Very good	Good	Average
1	8/8/2017	puzzles, } Quantz Sudoku }		✓		

4. Two positive points about the programme:

(\*) Explanation is good (\*) Easily understood.

5. Suggestions for improvement:

Nil

Date: 08/08/2017

M. Prabhakar  
Signature

TRAINING PROGRAMME FEEDBACK FORM

Name of the Student: Dinesh Kumar R

Branch: Mechanical IV - C

Year / Sem: IV / 07

4. Name of the Training : Appitude

5. Name of the Trainer : Susya

6. Students rating of Trainers :

S. No.	Date	Subject	Rating (√)			
			Excellent	Very good	Good	Average
1	8/8/2017	sentence selection, sentence formation.	✓			

4. Two positive points about the programme:

\* Explanation is good \* Easily understood.

5. Suggestions for improvement:

Nil

Date: 8/8/2017

PRINCIPAL,  
K. S. R. INSTITUTE FOR  
ENGINEERING AND TECHNOLOGY,  
K. S. R. KADAVANUR,  
TIRUCHENGODE - 637 215,  
NAMAVAL DE, TAMIL NADU.

R. Dinesh Kumar  
Signature



Ref: KSRIET/T&P/CIR/2017-18

Date: 24.07.2017

This is to inform that all the HoDs and department Training and Placement coordinators that the Four days (26.07.2017 to 29.07.2017) Aptitude Training Programme ( Phase I) for IV year students by Six Phrase during the academic year 2017 - 2018 (Odd Sem) has been scheduled as given below. All the registered students should attend the Training Programme without fail. If any student skips this Training Programme without proper permission from the respective HoDs, he / she will not be permitted for any further Training Programme and campus recruitment process. Proper Dress Code is mandatory.

**TIMINGS:**

FORENOON SESSION:

09:00 - 12:30 (Break - 10:45 - 11:00)

AFTERNOON SESSION:

01:30 - 04:15 (Break - 02:30 - 02:45)

  
T&P OFFICER

  
T&P COORDINATOR

  
PRINCIPAL

Copy to:

1. All HoDs
2. Notice Board

  
PRINCIPAL,  
K. S. R. INSTITUTE FOR  
ENGINEERING AND TECHNOLOGY,  
K. S. R. KALVI NAGAR,  
TIRUCHENGODE - 637 215,  
NAMAGAL DE, TAMIL NADU.

## K S R - Training Plan



Group 1	FN - Session 1	FN - Session 2	AF - Session 1	AF - Session 2
Batch 1	A1/R1	V1	Lab Test	Lab Test
Batch 2	V1	A1/R1	Lab Test	Lab Test

A1/R1	Sharmila
V1	Krishnanand
Lab Test	xxxxxxxx
Lab Test	xxxxxxxx

Group 2	FN - Session 1	FN - Session 2	AF - Session 1	AF - Session 2
Batch 3	Lab Test	Lab Test	A1/R1	V1
Batch 4	Lab Test	Lab Test	V1	A1/R1

A1/R1	Sharmila
V1	Krishnanand
Lab Test	xxxxxxxx
Lab Test	xxxxxxxx

### Topics

Day 1	A1	Numbers
	R1	logical Deductions
	V1	Synonyms ✓
Day 2	A1	permutation and combination
	R1	Data Sufficiency
	V1	Sentence Completion ✓
Day 3	A1	Geometry And Mensuration
	R1	Odd Man Out ✓
	V1	Antonyms ✓
Day 4	A1	Algebra
	R1	Image Based Problems
	V1	Selecting Words , Spotting Errors ✓

  
 PRINCIPAL,  
 K. S. R. INSTITUTE FOR  
 ENGINEERING AND TECHNOLOGY,  
 K. S. R. KALIT NAGAR,  
 TIRUCHENGODE - 637 215,  
 NARASIPET, TAMIL NADU.

July 2017 Training Dates  
 26, 27, 28, 29

**Phase 1 Test Topics**

Day	Title	Topics
Day 1	Aptitude	Quantitative Aptitude New -- Numbers -- Test 1
	Reasoning	Reasoning Aptitude -- Logical Deductions -- Test 1
	Verbal	Verbal Aptitude New -- Synonyms -- Test 1
Day 2	Aptitude	Quantitative Aptitude New -- Permutation & Combination-- Test 1
	Reasoning	Reasoning Aptitude New --Data Sufficiency -- Test 1
	Verbal	Verbal Aptitude New -- Sentence Completion-- Test 1
Day 3	Aptitude	Quantitative Aptitude New -- Geometry And Mensuration-- Test 1
	Reasoning	Reasoning Aptitude New -- Odd Man Out -- Test 1
	Verbal	Verbal Aptitude New -- Antonyms -- Test 1
Day 4	Aptitude	Quantitative Aptitude New -- Algebra -- Test 1
	Reasoning	Reasoning Aptitude New -- Image Based Problems -- Test 1
	Verbal	Verbal Aptitude New --Selecting Words -- Test 1
Day 5	Aptitude	CTS Model Test 1 --- 29
	Reasoning	
	Verbal	
Day 6	Aptitude	CTS Model Test 1 --- 28
	Reasoning	
	Verbal	
Day 7	Aptitude	CTS Model Test 1 --- 27
	Reasoning	
	Verbal	
Day 8	Aptitude	CTS Model Test 1 --- 26
	Reasoning	
	Verbal	
Day 9	Aptitude	CTS Model Test 1 --- 25
	Reasoning	
	Verbal	
Day 10	Aptitude	CTS Model Test 1 --- 24
	Reasoning	
	Verbal	
Day 11	Aptitude	CTS Model Test 1 --- 24
	Reasoning	
	Verbal	
Day 12	Aptitude	CTS Model Test 1 --- 23
	Reasoning	
	Verbal	

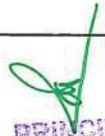
  
**PRINCIPAL,**  
**K. S. R. INSTITUTE FOR**  
**ENGINEERING AND TECHNOLOGY,**  
**K. S. R. KALVI NAGAR,**  
**TIRUCHENGODE - 637 216,**  
**NAGARHALLI Dt, TAMIL NADU.**



BATCH : 2014 - 2018

Academic Year: 2017 - 2018

Year / Sem: IV / VII

Staff Incharge:

S. No	Reg No	Name	Branch	26/7/17				27/7/17				28/7/17				29/7/17			
				FN	FN	AN	AN	FN	FN	AN	AN	FN	FN	AN	AN	FN	FN	AN	AN
1	731614104003	ASWIN SANKAR C	CSE	/	/	/	/	/	/	/	/	/	/	/	/	/	/	/	
2	731614104005	CHINDHAMANI R M	CSE	/	/	/	/	/	/	/	/	/	/	/	/	/	/	/	
3	731614104006	CHITHRADEVI G	CSE	/	/	/	/	/	/	/	/	/	/	/	/	/	/	/	
4	731614104014	JEEVITHA R	CSE	/	/	/	/	/	/	/	/	/	/	/	/	/	/	/	
5	731614104015	JENITHA K	CSE	/	/	/	/	/	/	/	/	/	/	/	/	/	/	/	
6	731614104018	KEERTHANA D	CSE	/	/	/	/	/	/	/	/	/	/	/	/	/	/	/	
7	731614104019	KEERTHANA P	CSE	/	/	/	/	/	/	/	/	/	/	/	/	/	/	/	
8	731614104025	NIVEDITHA S	CSE	/	/	/	/	/	/	/	/	/	/	/	/	/	/	/	
9	731614104027	PRIYANKA N	CSE	P	P	P	P	P	P	P	P	P	P	P	P	P	P	P	
10	731614104038	THIRUMURUGAN S	CSE	/	/	/	/	/	/	/	/	/	/	/	/	/	P	P	
11	731614104041	VIGNESH PERUMAL R	CSE	/	/	/	/	/	/	/	/	/	/	/	/	/	/	/	
12	731614104702	ANBHUCKARASI P	CSE	/	/	/	/	/	/	/	/	/	/	/	/	/	/	/	
13	731614205002	GODSON VINCE ALEX A	IT	/	/	/	/	/	/	/	/	/	/	/	/	/	/	/	
14	731614205004	ILAKKIYA S	IT	/	/	/	/	/	/	/	/	/	/	/	/	/	/	/	
15	731614205006	MEPHYMONY D	IT	/	/	/	/	/	/	/	/	/	/	/	/	/	/	/	
16	731614205007	NANTHAKUMAR S	IT	/	/	/	/	/	/	/	/	/	/	/	/	/	/	/	
17	731614205011	SOWNTHIRYA M	IT	/	/	/	/	/	/	/	/	/	/	/	/	/	/	/	
18	731614105002	ANITHA M	EEE A	/	/	/	/	/	/	/	/	/	/	/	/	/	/	/	
19	731614105006	BOOPALAN R	EEE A	/	/	/	/	/	/	/	/	/	/	/	/	/	/	/	
20	731614105010	DIVYABHARATHI S	EEE A	/	/	/	/	/	/	/	/	/	/	/	/	/	/	/	
21	731614105011	DIYANA S	EEE A	/	/	/	/	/	/	/	/	/	/	/	/	/	/	/	
22	731614105013	GOMATHI P K	EEE A	/	/	/	/	/	/	/	/	/	/	/	/	/	/	/	
23	731614105019	HARINI K	EEE A	/	/	/	/	/	/	/	/	/	/	/	P	P	P	P	
24	731614105023	KANAGA PRIYA R	EEE A	/	/	/	/	/	/	/	/	/	/	/	/	/	/	/	
25	731614105025	KARTHICK B	EEE A	/	/	/	/	/	/	/	/	/	/	/	/	/	/	/	
26	731614105026	KARTHIGA N	EEE A	/	/	/	/	/	/	/	/	/	/	/	/	/	/	/	
27	731614105027	KARTHIK T M	EEE A	/	/	/	/	/	/	/	/	/	/	/	/	/	/	/	
28	731614105029	KEERTHANA A	EEE A	/	/	/	/	/	/	/	/	/	/	/	/	/	/	/	
29	731614105030	KESAVAN R	EEE A	/	/	/	/	/	/	/	/	/	/	/	/	/	/	/	
30	731614105031	LAVANYA G	EEE A	/	/	/	/	/	/	/	/	/	/	/	/	/	/	/	
31	731614105303	JEEVA V	EEE A	/	/	/	/	/	/	/	/	/	/	/	/	/	/	/	
32	731614105304	KEERTHANA S	EEE A	/	/	/	/	/	/	/	/	/	/	/	/	/	/	/	
33	731614105040	NOORNIHARA	EEE B	/	/	/	/	/	/	/	/	/	/	/	/	/	/	/	
34	731614105050	RANJITH T	EEE B	/	/	/	/	/	/	/	/	/	/	/	/	/	/	/	
35	731614105055	SANGAVI K	EEE B	/	/	/	/	P	P	P	P	/	/	/	/	/	/	/	
36	731614105067	THIYAGARAJAN S	EEE B	/	/	/	/	/	/	/	/	/	/	/	/	/	/	/	
37	731614106003	ARTHI K	ECE	/	/	/	/	/	/	/	/	/	/	/	/	/	/	/	

PRINCIPAL,  
K. S. R. INSTITUTE FOR  
ENGINEERING AND TECHNOLOGY,  
K. S. R. KALVI NAGAR,  
TIRUCHENGOODE - 637 215,  
NAMAKKAL DISTRICT, TAMIL NADU.

39	731614106013	ELIZABETH N J	ECE	/	/	/	/	/	/	/	/	/	/	/	/	/	/	/		
40	731614106018	HEMAVARTHINI M	ECE	/	/	/	/	/	/	/	/	/	/	/	/	/	/	/		
41	731614106020	JANANI T	ECE	/	/	/	/	/	/	/	/	P	T	/	/	/	/	/		
42	731614106021	JANANI V.S	ECE	/	/	/	/	P	P	P	P	/	/	/	/	/	/	/		
43	731614106024	KAAYIYA M	ECE	/	/	/	/	/	/	/	/	/	/	/	/	/	/	/		
44	731614106030	KARTHIKA S	ECE	/	/	/	/	/	/	/	/	/	/	/	/	/	/	/		
45	731614106034	KEERTHANA S	ECE	/	/	/	/	/	/	/	/	/	/	/	/	/	/	/		
46	731614106037	LOGANATHAN C	ECE	/	/	/	/	/	/	/	/	/	/	/	/	/	/	/		
47	731614106039	LOKESH KUMAR V	ECE	/	/	/	/	/	/	/	/	/	/	/	/	/	/	/		
48	731614106044	MANOJ KUMAR K	ECE	/	/	/	/	/	/	/	/	/	/	/	/	/	/	/		
49	731614106062	RAVI S	ECE	P	P	P	P	/	/	/	/	/	/	/	/	/	/	/		
50	731614106065	SANKARI M	ECE	/	/	/	/	/	/	/	/	/	/	/	/	/	/	/		
51	731614106074	SIVA RANJANI .P	ECE	/	/	/	/	/	/	/	/	/	/	/	/	/	/	/		
52	731614106076	SRIDHAR T	ECE	/	/	/	/	/	/	/	/	/	/	/	/	/	/	/		
53	731614106079	SUGUMAR S	ECE	/	/	/	/	/	/	/	/	/	/	/	/	/	/	/		
54	731614106080	SURIYA V	ECE	/	/	/	/	/	/	/	/	/	/	/	/	/	/	/		
<b>PRESENT</b>				52	52	52	52	51	51	51	51	54	54	53	54	53	53	52	53	
<b>ABSENT</b>				0	0	0	0	0	0	0	0	0	0	0	0	0	0	0	0	0
<b>PERMISSION</b>				2	2	2	2	3	3	3	3	0	0	1	0	1	1	2	2	
<b>TOTAL</b>				54	54	54	54	54	54	54	54	54	54	54	54	54	54	54	54	54

  
**PRINCIPAL,**  
**K. S. R. INSTITUTE FOR**  
**ENGINEERING AND TECHNOLOGY,**  
**K. S. R. KALVI NAGAR,**  
**TIRUCHENGOORU - 637 215,**  
**NAMANKAL, TN, INDIA.**

## Training and Placement Cell

## SIX PHASE TRAINING PROGRAMME - PHASE - 1

BATCH : 2014 - 2018

Academic Year: 2017 - 2018

Sem: IV / VII

BATCH - 1

Staff Incharge:

S.No.	Reg No.	Name	Dept	26.07.2017	
				FN	AN
1	731614105028	KAVIN KUMAR M	B.E-EEE	/	/
2	731614105074	R.VINOTH KUMAR	B.E-EEE	/	/
3	731614106010	DHIVYA PRABHA P	B.E-ECE	P	P
4	731614106023	JOTHIPRAKASH R	B.E-ECE	/	/
5	731614106046	NANDHINI M	B.E-ECE	/	/
6	731614106059	PRIYA R	B.E-ECE	/	/
7	731614106063	RAVI VARMA B	B.E-ECE	/	/
8	731614106075	SOUNDHARYA.V	B.E-ECE	/	/
9	731614114011	ARAVINDHAN A J	B.E-MECH	/	/
10	731614114059	S.KARTHI	B.E-MECH	/	/
11	731614114066	KISHORKUMARAN.S	B.E-MECH	/	/
12	731614114146	SURYA .M	B.E-MECH	/	/
13	731614114316	MUDALIYAR VISHNU	B.E-MECH	/	/
14	731614205009	PRAKASH A	B.TECH-IT	/	/
15	731614104302	KARTHIK RAJA.J	B.E-CSE	/	/
16	731614104306	SABARINATHAN S	B.E-CSE	/	/
17	731614105005	S.BAWADHARANI	B.E-EEE	/	/
18	731614105039	T.NANDHINI	B.E-EEE	/	/
19	731614105059	SOUNDARAKUMAR C	B.E-EEE	/	/
20	731614106001	ABINAYA R	B.E-ECE	A	A
21	731614106005	ATCHAYA R	B.E-ECE	/	/
22	731614106011	DIVYA.S	B.E-ECE	/	/
23	731614106017	GOVINDARAJ M	B.E-ECE	/	/
24	731614106036	KRISHNAA M	B.E-ECE	/	/
25	731614106048	NIVETHA A	B.E-ECE	/	/
26	731614114031	K.DHANUSH KUMAR	B.E-MECH	/	/
27	731614114040	GOKUL RAJ M	B.E-MECH	/	/
28	731614114048	HARIHARAN.S	B.E-MECH	/	/
29	731614114087	MOHAN S	B.E-MECH	/	/
30	731614114088	MOHAN RAJ R	B.E-MECH	/	/
31	731614114094	S.MUTHURAJ	B.E-MECH	/	/
32	731614114110	PRASANTH.C	B.E-MECH	/	/
33	731614114114	RADHAKRISHNAN S	B.E-MECH	/	/
34	731614114326	SURENDAR. A	B.E-MECH	/	/

PRINCIPAL,  
K. S. R. INSTITUTE FOR  
ENGINEERING AND TECHNOLOGY,  
K. S. R. KALVI NAGAR,  
TIRUPUR - 637 215,  
NAMAGAL OD, TAMIL NADU.

**Training and Placement Cell**

**SIX PHASE TRAINING PROGRAMME - PHASE - 1**

**BATCH : 2014 - 2018**

**Academic Year: 2017 - 2018**

**Sem: IV / VII**

**BATCH - 1**

**Staff Incharge:**

S.No.	Reg No.	Name	Dept	26.07.2017	
				FN	AN
35	731614105017	HARIHARAN G	B.E-EEE	/	/
36	731614114054	Jayaprakash R	B.E-MECH	/	/
37	731614114069	Lavanya S	B.E-MECH	/	/
38	731614114074	Mahendran A	B.E-MECH	/	/
39	731614114086	Mohan P	B.E-MECH	/	/
40	731614114077	Manoj Kumar R	B.E-MECH	/	/
41	731614114136	Shivakumar S	B.E-MECH	/	/
42	731614114116	Rajasekar A	B.E-MECH	/	/
43	731614114163	Vijay S	B.E-MECH	/	/
44	731614114095	Nainar Mohammad	B.E-MECH	/	/
45	731614114139	Sridhar K	B.E-MECH	/	/
46	731614114159	Venugopal V	B.E-MECH	/	/
47	731614114156	Venkadesh S	B.E-MECH	/	/
48	731614114141	V Srinath	B.E-MECH	/	/
49	731614114098	Naveen P	B.E-MECH	/	/
50	731614114108	Prakashraj T	B.E-MECH	/	/
51	731614114142	Srinivasan P	B.E-MECH	/	/
52	731614114160	Vignesh D	B.E-MECH	/	/
53	731614114150	TamilselvaN s	B.E-MECH	/	/
54	731614114704	Arun SV	B.E-MECH	/	/
			<b>PRESENT</b>	53	53
			<b>ABSENT</b>	1	1
			<b>PERMISSION</b>	1	1
			<b>OD</b>		

**Session**

Theory  
Practice

**Timings**

FN: 09:15 to 12:30  
AN: 01:30 to 04:45

**Venue**

101  
CAD LAB

**Practice Lab**

01:30 - 02:30  
02:30 - 03:00

**Practice Lab**

03:15 - 04:15  
04:15 - 04:45

**Session - I**

Test - 01 Hour  
Discussion- 30 Mints

**Session - II**

Test - 01 Hour  
Discussion- 30 Mints

**Tpoic**

App + Verbal

**Tpoic**

App + Verbal

**PRINCIPAL,**

**K. S. R. INSTITUTE FOR  
ENGINEERING AND TECHNOLOGY,  
K. S. R. KALVI NAGAR,  
TIRUCHENGODE - 637 215,  
NAMAKKAL DT, TAMIL NADU.**

## Training and Placement Cell

## SIX PHASE TRAINING PROGRAMME - PHASE - 1

BATCH : 2014 - 2018

Academic Year: 2017 - 2018

Sem: IV / VII

BATCH - 1

Staff Incharge:

Mech

S.No.	Reg No.	Name	Dept	27.07.2017		28.07.2017		29.07.2017	
				FN	AN	FN	AN	FN	AN
1	731614106067	SARAVANAN R	B.E-ECE	/	/	/	/	a	a
2	731614114041	P.GOWTHAM	B.E-MECH	/	/	/	/	/	/
3	731614114042	GOWTHAM.S	B.E-MECH	/	/	/	/	/	/
4	731614104007	M.DEEPAKFERNADEZ	B.E-CSE	d	/	/	/	/	/
5	731614114049	S.HARIHARASUDAN	B.E-MECH	/	P	P	P	/	/
6	731614114051	N.HARISHANKAR	B.E-MECH	/	/	/	/	/	/
7	731614114166	VIJAYAKUMAR M	B.E-MECH	/	/	/	/	/	/
8	731614106027	KANMANI R	B.E-ECE	/	/	/	/	/	/
9	731614105058	SOMA SUNDARAM.R	B.E-EEE	/	/	/	/	/	/
10	731614106032	KATHIRESH S	B.E-ECE	/	/	/	/	/	/
11	731614114015	ARJUN B	B.E-MECH	/	/	/	/	/	/
12	731614114050	HARISH	B.E-MECH	/	/	/	/	P	P
13	731614105053	ROKESH KUMAR R	B.E-EEE	/	/	/	/	P	P
14	731614105062	S.SURYA	B.E-EEE	/	/	/	/	/	/
15	731614106015	GOKUL RAJ K.N	B.E-ECE	/	/	/	/	/	/
16	731614106082	THAMARAIKANNAN S	B.E-ECE	/	/	/	/	/	/
17	731614114003	M.AJITHKUMAR	B.E-MECH	/	/	/	/	/	/
18	731614114018	ARUL PRAKASH.P	B.E-MECH	/	/	/	/	/	/
19	731614114020	ARUNKUMAR	B.E-MECH	/	/	/	/	/	/
20	731614114038	GOKUL KUMAR R	B.E-MECH	/	/	/	/	/	/
21	731614114043	S.GOWTHAMAN	B.E-MECH	/	/	/	/	/	/
22	731614114089	MUGILESHWARAN K	B.E-MECH	/	/	/	/	/	/
23	731614114311	JEEVA S	B.E-MECH	/	/	/	/	/	/
24	731614105033	MATHANA GOPAL.G	B.E-EEE	/	/	/	P	/	/
25	731614114012	S.ARAVINDHARAJ	B.E-MECH	/	/	/	/	/	/
26	731614114036	EYAD MUHAMMED	B.E-MECH	/	/	/	/	/	/
27	731614114037	GANESHKARTHIK	B.E-MECH	/	/	/	/	/	/
28	731614114068	KUMARAN E	B.E-MECH	/	/	/	/	/	/
29	731614114151	S.TARUN CHOUHAN	B.E-MECH	/	/	/	/	/	/
30	731614114303	DINESHKUMAR R	B.E-MECH	/	/	/	/	/	/
31	731614106009	DHIVYA DHARANI J	B.E-ECE	/	/	/	/	/	/
32	731614106070	SHARANYA A	B.E-ECE	/	/	/	/	/	/
33	731614114033	DINESH.S.V	B.E-MECH	/	/	/	/	/	/
34	731614114039	L.GOKULPRASATH	B.E-MECH	/	/	/	/	/	/

PRINCIPAL,  
K. S. R. INSTITUTE FOR  
ENGINEERING AND TECHNOLOGY,  
K. S. R. KALVI NAGAR,  
TIRUCHENGODE - 637 215,  
NARAKKAL, TAMIL NADU.

**Training and Placement Cell**  
**SIX PHARSE TRAINING PROGRAMME - PHASE - 1**

BATCH : 2014 - 2018

Academic Year: 2017 - 2018

Sem: IV / VII

BATCH - 1

Staff Incharge:

Mech

S.No.	Reg No.	Name	Dept	27.07.2017		28.07.2017		29.07.2017	
				FN	AN	FN	AN	FN	AN
35	731614104026	POORNIMA.M	B.E-CSE	/	/	/	/	/	/
36	731614105003	ARAVINDHAN B	B.E-EEE	/	/	/	/	/	/
37	731614105021	HARIRAMU.R	B.E-EEE	/	/	/	/	/	/
38	731614105072	VIJAY R	B.E-EEE	/	/	/	/	/	/
39	731614106051	PARTHASARATHI M M	B.E-ECE	/	/	/	/	/	/
40	731614106085	VINOTHINI P	B.E-ECE	/	/	/	/	/	/
41	731614106307	RANGANATHAN S	B.E-ECE	/	/	/	/	/	/
42	731614114007	ANAND S	B.E-MECH	/	/	/	/	/	/
43	731614114028	R.DEVAN	B.E-MECH	/	/	a	a	/	/
44	731614114029	N.DEVARAJ	B.E-MECH	/	/	/	/	/	/
45	731614114034	DINESH KUMAR.M	B.E-MECH	/	/	/	/	/	/
46	731614114070	LAXMANAN M	B.E-MECH	/	/	/	/	/	/
47	731614114080	MITHUN CHAKRAVARTHY	B.E-MECH	/	/	P	/	/	/
48	731614114124	SABAREESAN M	B.E-MECH	/	/	/	/	/	/
49	731614114134	K.SATHISHRAJ	B.E-MECH	/	/	/	/	/	/
50	731613114017	Arjun T	B.E-MECH	P	P	P	P	P	P
51	731613114052	Izaz AhAMMED	B.E-MECH	/	/	/	/	a	a
52	731613114143	Sukruth B	B.E-MECH	/	/	/	/	/	/
53	731613114144	Suresh P	B.E-MECH	/	/	/	/	/	/
54	731613114102	Nivasan K	B.E-MECH	/	/	/	/	/	/
55	731613114123	RanjithKumar S	B.E-MECH	/	/	/	/	/	/
<b>PRESENT</b>				52	53	52	51	50	49
<b>ABSENT</b>				00	00	01	01	02	03
<b>PERMISSION</b>				01	02	02	03	03	03
<b>OD</b>				-	-	-	-	-	-

**Session**  
Theory  
Practice

**Timingis**  
FN: 09:15 to 12:30  
AN: 01:30 to 04:45

**Venue**  
101  
CAD LAB

**Break Timings**  
FN: 10:45 to 11:00  
AN: 03:00 to 03:15

**Practice Lab**  
01:30 - 02:30  
02:30 - 03:00  
**Practice Lab**  
03:15 - 04:15  
04:15 - 04:45

**Session - I**  
Test - 01 Hour  
Discussion- 30 Mints  
**Session - II**  
Test - 01 Hour  
Discussion- 30 Mints

**Tpoic**  
App + Verbal  
**Tpoic**  
App + Verbal

  
**PRINCIPAL,**  
**K. S. R. INSTITUTE FOR**  
**ENGINEERING AND TECHNOLOGY,**  
**K. S. R. KALVI NAGAR,**  
**TIRUCHENGOODE - 637 215,**  
**NAMAKKAL DL, TAMIL NADU.**

S.No.	Reg No.	Name	Dept	26.07.2017	
				FN	AN
1	731614106067	SARAVANAN R	B.E-ECE	/	/
2	731614114041	P.GOWTHAM	B.E-MECH	/	/
3	731614114042	GOWTHAM.S	B.E-MECH	/	/
4	731614104007	M.DEEPAKFERNADEZ	B.E-CSE	/	/
5	731614114049	S.HARIHARASUDAN	B.E-MECH	/	/
6	731614114051	N.HARISHANKAR	B.E-MECH	/	/
7	731614114166	VIJAYAKUMAR M	B.E-MECH	/	/
8	731614106027	KANMANI R	B.E-ECE	/	/
9	731614105058	SOMA SUNDARAM.R	B.E-EEE	/	/
10	731614106032	KATHIRESH S	B.E-ECE	P	P
11	731614114015	ARJUN B	B.E-MECH	/	/
12	731614114050	HARISH	B.E-MECH	/	/
13	731614105053	ROKESH KUMAR R	B.E-EEE	/	/
14	731614105062	S.SURYA	B.E-EEE	/	/
15	731614106015	GOKUL RAJ K.N	B.E-ECE	/	/
16	731614106082	THAMARA KANNAN S	B.E-ECE	/	/
17	731614114003	M.AJITHKUMAR	B.E-MECH	/	/
18	731614114018	ARUL PRAKASH.P	B.E-MECH	/	/
19	731614114020	ARUNKUMAR	B.E-MECH	/	/
20	731614114038	GOKUL KUMAR R	B.E-MECH	/	/
21	731614114043	S.GOWTHAMAN	B.E-MECH	/	/
22	731614114089	MUGILESHWARAN K	B.E-MECH	/	/
23	731614114311	JEEVA S	B.E-MECH	/	/
24	731614105033	MATHANA GOPAL.G	B.E-EEE	/	/
25	731614114012	S.ARAVINDHARAJ	B.E-MECH	/	/
26	731614114036	EYAD MUHAMMED	B.E-MECH	P	P
27	731614114037	GANESHKARTHIK	B.E-MECH	/	/
28	731614114068	KUMARAN E	B.E-MECH	/	/
29	731614114151	S.TARUN CHOUHAN	B.E-MECH	/	/
30	731614114303	DINESHKUMAR R	B.E-MECH	/	/
31	731614106009	DHIVYA DHARANI J	B.E-ECE	/	/
32	731614106070	SHARANYA A	B.E-ECE	/	/
33	731614114033	DINESH.S.V	B.E-MECH	/	/
34	731614114039	L.GOKULPRASATH	B.E-MECH	/	/

**Training and Placement Cell**

**SIX PHASE TRAINING PROGRAMME - PHASE - 1**

**BATCH : 2014 - 2018**

**Academic Year: 2017 - 2018**

**Sem: IV / VII**

**BATCH - 1**

**Staff Incharge:**

S.No.	Reg No.	Name	Dept	26.07.2017	
				FN	AN
35	731614104026	POORNIMA.M	B.E-CSE	/	/
36	731614105003	ARAVINDHAN B	B.E-EEE	/	/
37	731614105021	HARIRAMU.R	B.E-EEE	/	/
38	731614105072	VIJAY R	B.E-EEE	/	/
39	731614106051	PARTHASARATHI M M	B.E-ECE	/	/
40	731614106085	VINOTHINI P	B.E-ECE	/	/
41	731614106307	RANGANATHAN S	B.E-ECE	/	/
42	731614114007	ANAND S	B.E-MECH	/	/
43	731614114028	R.DEVAN	B.E-MECH	/	/
44	731614114029	N.DEVARAJ	B.E-MECH	/	/
45	731614114034	DINESH KUMAR.M	B.E-MECH	/	/
46	731614114070	LAXMANAN M	B.E-MECH	/	/
47	731614114080	MITHUN CHAKRAVARTHY	B.E-MECH	/	/
48	731614114124	SABAREESAN M	B.E-MECH	/	/
49	731614114134	K.SATHISHRAJ	B.E-MECH	/	/
50	731613114017	Arjun T	B.E-MECH	/	/
51	731613114052	Izaz AhAMMED	B.E-MECH	/	/
52	731613114143	Sukruth B	B.E-MECH	A	A
53	731613114144	Suresh P	B.E-MECH	/	/
54	731613114102	Nivasan K	B.E-MECH	/	/
55	731613114123	RanjithKumar S	B.E-MECH	/	/
<b>PRESENT</b>				52	52
<b>ABSENT</b>				1	1
<b>PERMISSION</b>				2	2
<b>OD</b>					

**Session**

Theory  
Practice

**Timingis**

FN: 09:15 to 12:30  
AN: 01:30 to 04:45

**Venue**

101  
CAD LAB

**Practice Lab**

01:30 - 02:30  
02:30 - 03:00  
**Practice Lab**  
03:15 - 04:15  
04:15 - 04:45

**Session - I**

Test - 01 Hour  
Discussion- 30 Mints

**Session - II**

Test - 01 Hour  
Discussion- 30 Mints

**Tpoic**

App + Verbal

**Tpoic**

App + Verbal

  
**PRINCIPAL,**  
**K. S. R. INSTITUTE FOR**  
**ENGINEERING AND TECHNOLOGY,**  
**K. S. R. KALW NAGAR,**  
**TIRUCHENGOODE - 637 215,**  
**NAIDAKKAL, TN, TAMIL NADU.**



## Training and Placement Cell

## SIX PHASE TRAINING PROGRAMME - PHASE - 1

BATCH : 2014 - 2018

Academic Year: 2017 - 2018

Sem: IV / VII

BATCH - 2

Staff Incharge:

Mech

S.No.	Reg No.	Name	Dept	27.07.2017		28.07.2017		29.07.2017	
				FN	AN	FN	AN	FN	AN
1	731614105028	KAVIN KUMAR M	B.E-EEE	/	/	/	/	/	/
2	731614105074	R.VINOTH KUMAR	B.E-EEE	/	/	/	/	/	/
3	731614106010	DHIVYA PRABHA P	B.E-ECE	/	/	/	/	/	/
4	731614106023	JOTHIPRAKASH R	B.E-ECE	/	/	/	/	/	/
5	731614106046	NANDHINI M	B.E-ECE	/	/	/	/	/	/
6	731614106059	PRIYA R	B.E-ECE	/	/	/	/	/	/
7	731614106063	RAVI VARMA B	B.E-ECE	/	/	/	/	/	/
8	731614106075	SOUNDHARYA.V	B.E-ECE	/	/	/	/	/	/
9	731614114011	ARAVINDHAN A J	B.E-MECH	/	/	/	/	/	/
10	731614114059	S.KARTHI	B.E-MECH	/	/	/	/	/	/
11	731614114066	KISHORKUMARAN.S	B.E-MECH	/	/	/	/	/	/
12	731614114146	SURYA .M	B.E-MECH	/	/	/	/	P	P
13	731614114316	MUDALIYAR VISHNU	B.E-MECH	/	/	/	/	/	/
14	731614205009	PRAKASH A	B.TECH-IT	/	/	/	/	P	P
15	731614104302	KARTHIK RAJA.J	B.E-CSE	/	/	/	/	/	/
16	731614104306	SABARINATHAN S	B.E-CSE	/	/	/	/	/	/
17	731614105005	S.BAWA DHARANI	B.E-EEE	/	/	/	/	/	/
18	731614105039	T.NANDHINI	B.E-EEE	/	/	/	/	/	/
19	731614105059	SOUNDARAKUMAR C	B.E-EEE	/	/	/	/	/	/
20	731614106001	ABINAYA R	B.E-ECE	/	/	/	/	/	/
21	731614106005	ATCHAYA R	B.E-ECE	/	/	/	/	a	a
22	731614106011	DIVYA.S	B.E-ECE	/	/	/	/	/	/
23	731614106017	GOVINDARAJ M	B.E-ECE	/	/	/	/	/	/
24	731614106036	KRISHNAA M	B.E-ECE	/	/	/	/	/	/
25	<del>731614106048</del>	<del>NIVETHA A</del>	<del>B.E-ECE</del>	<del>/</del>	<del>/</del>	<del>/</del>	<del>/</del>	<del>/</del>	<del>/</del>
26	731614114031	K.DHANUSH KUMAR	B.E-MECH	a	a	a	a	/	/
27	731614114040	GOKUL RAJ M	B.E-MECH	/	/	/	/	/	/
28	731614114048	HARIHARAN.S	B.E-MECH	/	/	/	/	/	/
29	731614114087	MOHAN S	B.E-MECH	/	/	/	/	/	/
30	731614114088	MOHAN RAJ R	B.E-MECH	/	/	/	/	/	/
31	731614114094	S.MUTHURAJ	B.E-MECH	/	/	/	/	/	/
32	731614114110	PRASANTH.C	B.E-MECH	/	/	/	/	/	/
33	731614114114	RADHAKRISHNAN S	B.E-MECH	/	/	/	/	/	/
34	731614114326	SURENDAR. A	B.E-MECH	/	/	/	/	/	/

PRINCIPAL,  
K. S. R. INSTITUTE FOR  
ENGINEERING AND TECHNOLOGY,  
K. S. R. SALAI NAGAR,  
TRICHENGODE - 637 215,  
NAMAKKAL DISTRICT, TAMIL NADU.

**Training and Placement Cell**  
**SIX PHASE TRAINING PROGRAMME - PHASE - 1**

BATCH : 2014 - 2018

Academic Year: 2017 - 2018

Sem: IV / VII

BATCH - 2

Staff Incharge:

Mech

S.No.	Reg No.	Name	Dept	27.07.2017		28.07.2017		29.07.2017		
				FN	AN	FN	AN	FN	AN	
35	731614105017	HARIHARAN G	B.E-EEE	/	/	/	/	a	a	
36	731614114054	Jayaprakash R	B.E-MECH	/	/	/	/	/	/	
37	731614114069	Lavanya S	B.E-MECH	a	a	a	a	a	a	
38	731614114074	Mahendran A	B.E-MECH	/	/	/	/	/	/	
39	731614114086	Mohan P	B.E-MECH	/	/	/	/	/	/	
40	731614114077	Manoj Kumar R	B.E-MECH	/	/	/	/	/	/	
41	731614114136	Shivakumar S	B.E-MECH	/	/	/	/	/	/	
42	731614114116	Rajasekar A	B.E-MECH	/	/	/	/	/	/	
43	731614114163	Vijay S	B.E-MECH	/	/	/	/	/	/	
44	731614114095	Nainar Mohammad	B.E-MECH	/	/	/	/	/	/	
45	731614114139	Sridhar K	B.E-MECH	/	/	/	/	/	/	
46	731614114159	Venugopal V	B.E-MECH	/	/	/	/	a	a	
47	731614114156	Venkadesh S	B.E-MECH	/	/	/	/	/	/	
48	731614114141	V Srinath	B.E-MECH	/	/	/	/	/	/	
49	731614114098	Naveen P	B.E-MECH	/	/	/	/	/	/	
50	731614114108	Prakashraj T	B.E-MECH	/	/	/	/	/	/	
51	731614114142	Srinivasan P	B.E-MECH	/	/	/	/	/	/	
52	731614114160	Vignesh D	B.E-MECH	/	/	/	/	a	a	
53	731614114150	TamilselvaN s	B.E-MECH	/	/	/	/	/	/	
54	731614114704	Arun SV	B.E-MECH	/	/	/	/	/	/	
				PRESENT	51	51	51	51	46	46
				ABSENT	2	2	2	2	5	5
				PERMISSION	-	-	-	-	2	2
				OD	-	-	-	-	-	-

<b>Session</b>	<b>Timings</b>	<b>Venue</b>	<b>Break Timings</b>
Theory	FN: 09:15 to 12:30	102	FN: 10:45 to 11:00
Practice	AN: 01:30 to 04:45	Language Lab	AN: 03:00 to 03:15
<b>Practice Lab</b>	<b>Session - I</b>	<b>Tpoic</b>	
01:30 - 02:30	Test - 01 Hour	App + Verbal	
02:30 - 03:00	Discussion- 30 Mints		
<b>Practice Lab</b>	<b>Session - II</b>	<b>Tpoic</b>	
03:15 - 04:15	Test - 01 Hour	App + Verbal	
04:15 - 04:45	Discussion- 30 Mints		

  
**PRINCIPAL,**  
**K. S. R. INSTITUTE FOR**  
**ENGINEERING AND TECHNOLOGY,**  
**K. S. R. KALVI NAGAR,**  
**TIRUCHENGOORU - 637 215,**  
**TAMILNADU**

## SIX PHASE TRAINING PROGRAMME - PHASE - 1

BATCH : 2014 - 2018

Academic Year: 2017 - 2018

Sem: IV / VII

BATCH - 13

Staff Incharge:

S.No.	Reg No.	Name	Dept	26.07.2017	
				FN	AN
1	731614105042	PRAVEENKUMAR B	B.E-EEE	/	/
2	731614105060	STEEPANSIBU	B.E-EEE	/	/
3	731614106006	BARATH KUMAR M	B.E-ECE	/	/
4	731614106025	KALAI PRIYA N	B.E-ECE	/	/
5	731614106052	PAVITHRAN S	B.E-ECE	A	A
6	731614106064	SANGEETHA N	B.E-ECE	/	/
7	731614114024	BARATHRAJ	B.E-MECH	/	/
8	731614114046	HARIHARAN.K	B.E-MECH	/	/
9	731614114047	HARIHARAN.M	B.E-MECH	/	/
10	731614114097	NARESHKUMAR.B	B.E-MECH	/	/
11	731614114128	SAM PRAKASH.S	B.E-MECH	/	/
12	731614104002	ANGUPRAKASH V	B.E-CSE	/	/
13	731614104012	JAISRE.A	B.E-CSE	/	/
14	731614104021	MADHUBALAN T	B.E-CSE	/	/
15	731614104301	DHARANIR	B.E-CSE	/	/
16	731614105004	BALACHANDAR K R	B.E-EEE	/	/
17	731614105054	A.SABAREESWARAN	B.E-EEE	/	/
18	731614105068	E.UTHIRAKUMAR	B.E-EEE	/	/
19	731614105076	B.YOKESHWARAN	B.E-EEE	/	/
20	731614105305	D.MADHAN	B.E-EEE	/	/
21	731614106045	NAAGHA NAVEEN KUMAR V	B.E-ECE	P	P
22	731614106050	PADMAPRIYA E	B.E-ECE	/	/
23	731614106054	PRADEEPA S	B.E-ECE	/	/
24	731614106701	VIGNESHWAR B	B.E-ECE	/	/
25	731614114001	ABHIRAM T	B.E-MECH	/	/
26	731614114013	K.ARAVINTH	B.E-MECH	/	/
27	731614114023	BALAJIL	B.E-MECH	/	/
28	731614114030	A.DHANASEKARAN	B.E-MECH	/	/
29	731614114032	DHAYANITHIR	B.E-MECH	/	/
30	731614114061	KARTHIKEYAN.S	B.E-MECH	P	P
31	731614114062	KARTHIKEYAN	B.E-MECH	/	/
32	731614114083	MOHAMED RIYAZ.M	B.E-MECH	/	/
33	731614114085	MOHAMED YUNUS A	B.E-MECH	/	/
34	731614114091	MUHINTHAR. S	B.E-MECH	/	/

PRINCIPAL,  
K. S. R. INSTITUTE FOR  
ENGINEERING AND TECHNOLOGY,  
K. S. R. KALUVAHAR,  
TIRUPATI, A.P. - 507 215,  
NANDYAL BA, TAMIL NADU

Training and Placement Cell

SIX PHASE TRAINING PROGRAMME - PHASE - 1

BATCH : 2014 - 2018

Academic Year: 2017 - 2018

Sem: IV / VII

BATCH - 1

Staff Incharge:

S.No.	Reg No.	Name	Dept	26.07.2017	
				FN	AN
35	731614114133	SATHISH.K	B.E-MECH	P	P
36	731614114164	A.VINITHKUMAR	B.E-MECH	/	/
37	731614106012	DURGADEVI S	B.E-ECE	/	/
38	731614106060	Priyadharshini S	B.E-ECE	/	/
39		Karthi	B.Tech-IT	/	/
40		Vijay	B.Tech-IT	/	/
41	731614114084	Mohammed Sirajudeen	B.E-MECH	/	/
42	731614114115	RahulKumar K	B.E-MECH	/	/
43	731614114132	Saravana Manoj S	B.E-MECH	/	/
44	731614114140	Sridhar R	B.E-MECH	/	/
45	731614114101	Nethaji M	B.E-MECH	/	/
46	7316141140122	Ranjithkumar M	B.E-MECH	/	/
47	731614114126	Sabarigiri G	B.E-MECH	/	/
48	731614114149	Tamilmani p	B.E-MECH	/	/
49	731614114122	Ranjithkumar M	B.E-MECH	P	P
50	731614114106	Pradeep N	B.E-MECH	/	/
51	731614114312	Kaviyarasan S	B.E-MECH	/	/
52	731614114165	Viswanathan MS	B.E-MECH	/	/
53	731614114309	Gopinath K	B.E-MECH	/	/
PRESENT				47	47
ABSENT				1	1
PERMISSION				5	5
OD					

Session

Theory

Practice

Timingis

FN: 09:15 to 12:30

AN: 01:30 to 04:45

Venue

101

CAD LAB

Practice Lab

01:30 - 02:30

02:30 - 03:00

Practice Lab

03:15 - 04:15

04:15 - 04:45

Session - I

Test - 01 Hour

Discussion- 30 Mints

Session - II

Test - 01 Hour

Discussion- 30 Mints

Tpoic

App + Verbal

Tpoic

App + Verbal

PRINCIPAL,  
K. S. R. INSTITUTE FOR  
ENGINEERING AND TECHNOLOGY,  
K. S. R. KALVI NAGAR,  
TIRUCHENGODE - 637 215,  
NAMAKKAL DL, TAMIL NADU.

## Training and Placement Cell

## SIX PHASE TRAINING PROGRAMME - PHASE - 1

BATCH : 2014 - 2018

Academic Year: 2017 - 2018

Sem: IV / VII

BATCH - 3

Staff Incharge:

EEE

S.No.	Reg No.	Name	Dept	27.07.2017		28.07.2017		29.07.2017	
				FN	AN	FN	AN	FN	AN
1	731614105042	PRAVEENKUMAR B	B.E-EEE	X	X	X	X	X	X
2	731614105060	STEEPANSIBU	B.E-EEE	X	X	X	X	X	X
3	731614106006	BARATH KUMAR M	B.E-ECE	X	X	X	X	X	X
4	731614106025	KALAI PRIYA N	B.E-ECE	X	X	X	X	X	X
5	731614106052	PAVITHRAN S	B.E-ECE	X	X	X	X	X	X
6	731614106064	SANGEETHA N	B.E-ECE	X	X	X	X	X	X
7	731614114024	BARATHRAJ M	B.E-MECH	X	X	X	X	X	X
8	731614114046	HARIHARAN.K	B.E-MECH	X	X	X	X	X	X
9	731614114047	HARIHARAN.M	B.E-MECH	X	X	X	X	X	X
10	731614114097	NARESHKUMAR.B	B.E-MECH	X	X	X	X	X	X
11	731614114128	SAM PRAKASH.S	B.E-MECH	X	X	X	X	X	X
12	731614104002	ANGUPRAKASH V	B.E-CSE	X	X	X	X	X	X
13	731614104012	JASRE.A	B.E-CSE	X	X	X	X	X	X
14	731614104021	MADHUBALAN T	B.E-CSE	X	X	X	X	X	X
15	731614104301	DHARANIR	B.E-CSE	A	A	X	X	X	X
16	731614105004	BALACHANDAR K R	B.E-EEE	X	X	X	X	X	X
17	731614105054	A.SABAREESWARAN	B.E-EEE	X	X	X	X	X	X
18	731614105068	E.UTHIRAKUMAR	B.E-EEE	X	X	X	X	X	X
19	731614105076	B.YOKESHWARAN	B.E-EEE	X	X	X	X	X	X
20	731614105305	D.MADHAN	B.E-EEE	X	X	X	X	X	X
21	731614106045	NAAGHA NAVEEN KUMAR V	B.E-ECE	X	X	X	X	X	X
22	731614106050	PADMAPRIYA E	B.E-ECE	X	X	X	X	X	X
23	731614106054	PRADEEPA S	B.E-ECE	X	X	X	X	X	X
24	731614106701	VIGNESHWAR B	B.E-ECE	X	X	X	X	X	X
25	731614114001	ABHIRAM T	B.E-MECH	X	X	X	X	X	X
26	731614114013	K.KARAVINTH	B.E-MECH	X	X	X	X	X	X
27	731614114023	BALAJI.L	B.E-MECH	X	X	X	X	X	X
28	731614114030	A.DHANASEKARAN	B.E-MECH	X	X	X	X	X	X
29	731614114032	DHAYANITHIR	B.E-MECH	X	X	X	X	X	X
30	731614114061	KARTHIKEYAN.S	B.E-MECH	X	X	X	X	X	X
31	731614114062	KARTHIKEYAN .S	B.E-MECH	X	X	X	X	X	X
32	731614114083	MOHAMED RIYAZ.M	B.E-MECH	X	X	X	X	X	X
33	731614114085	MOHAMED YUNUS A	B.E-MECH	X	X	X	X	X	X
34	731614114091	MUHINTHAR. S	B.E-MECH	X	X	X	X	X	X

PRINCIPAL,  
K. S. R. INSTITUTE FOR  
ENGINEERING AND TECHNOLOGY,  
K. S. R. KALVI NAGAR,  
TIRUCHENGODE - 637 215,  
NARANKAL Dt, TAMIL NADU.

**Training and Placement Cell**  
**SIX PHASE TRAINING PROGRAMME - PHASE - 1**

BATCH : 2014 - 2018

Academic Year: 2017 - 2018

Sem: IV / VII

BATCH - 3

Staff Incharge:

EEE

S.No.	Reg No.	Name	Dept	27.07.2017		28.07.2017		29.07.2017	
				FN	AN	FN	AN	FN	AN
35	731614114133	SATHISH.K	B.E-MECH	X	X	X	X	X	X
36	731614114164	A.VINITHKUMAR	B.E-MECH	X	X	X	X	X	X
37	731614106012	DURGADEVI S	B.E-ECE	X	X	X	X	X	X
38	731614106060	Priyadharshini S	B.E-ECE	A	A	A	A	a	a
39	731614205005	Karthik P	B.Tech-IT	X	X	X	X	X	X
40	731614205013	Vijay S	B.Tech-IT	X	X	X	X	X	X
41	731614114084	Mohammed Sirajudeen	B.E-MECH	X	X	X	X	X	X
42	731614114115	RahulKumar K	B.E-MECH	X	X	X	X	X	X
43	731614114132	Saravana Manoj S	B.E-MECH	X	X	X	X	X	X
44	731614114140	Sridhar R	B.E-MECH	X	X	X	X	X	X
45	731614114101	Nethaji M	B.E-MECH	X	X	X	X	X	X
46	731614114012	Ranjithkumar C	B.E-MECH	X	X	X	X	X	o
47	731614114126	Sabarigiri G	B.E-MECH	X	X	X	X	X	X
48	731614114149	Tamilmani p	B.E-MECH	X	X	X	X	o	a
49	731614114122	Ranjithkumar M	B.E-MECH	X	X	X	X	X	X
50	731614114106	Pradeep N	B.E-MECH	X	X	X	X	X	X
51	731614114312	Kaviyarasan S	B.E-MECH	X	X	X	X	X	X
52	731614114165	Viswanathan MS	B.E-MECH	X	X	X	X	X	X
53	731614114309	Gopinath K	B.E-MECH	X	X	X	X	X	X
54		Prakash C	EEE	X	X	X	X	X	X
		Nivetha A	ECE PRESENT	X	X	X	X	X	X
			ABSENT						
			PERMISSION						
			OD						

<b>Session</b>	<b>Timingis</b>	<b>Venue</b>	<b>Break Timings</b>
Practice	FN: 09:15 to 12:30	CAD LAB	FN: 10:45 to 11:00
Theory	AN: 01:30 to 04:45	101	AN: 03:00 to 03:15
<b>Practice Lab</b>	<b>Session - I</b>	<b>Tpoic</b>	
09:15 - 10:15	Test - 01 Hour	App + Verbal	
10:15 - 10:45	Discussion- 30 Mints		
<b>Practice Lab</b>	<b>Session - II</b>	<b>Tpoic</b>	
11:00 - 12:00	Test - 01 Hour	App + Verbal	
12:00 - 12:30	Discussion- 30 Mints		

  
**PRINCIPAL,**  
**K. S. R. INSTITUTE FOR**  
**ENGINEERING AND TECHNOLOGY,**  
**K. S. R. KALVI NAGAR,**  
**TIRUCHENGOODE - 637 215,**  
**NAMAKKAL Dt, TAMIL NADU.**

S.No.	Reg No.	Name	Dept	26.07.2017	
				FN	AN
1	731614105073	N.VIJAYAN	B.E-EEE	/	/
2	731614105077	V.YUVARAJ	B.E-EEE	/	/
3	731614106007	DEEPAKRAJU C	B.E-ECE	/	/
4	731614106035	KOWSALYA.M	B.E-ECE	/	/
5	731614106049	OVIYA T	B.E-ECE	/	/
6	731614106077	SUBATHRA S	B.E-ECE	/	/
7	731614106311	UDHAYAKUMAR B	B.E-ECE	/	/
8	731614114027	DEEPANCHAKRAVARTHIS	B.E-MECH	/	/
9	731614114055	KAMALAKANNAN	B.E-MECH	/	/
10	731614114057	KARTHICK.P	B.E-MECH	/	/
11	731614114152	K.THIRULOGA SNTHAR	B.E-MECH	/	/
12	731614114154	VASANTH S	B.E-MECH	/	/
13	731614114314	D.MADHAN RAJ	B.E-MECH	/	/
14	731614104033	SARAVANA ABISHEK.G	B.E-CSE	/	/
15	731614105035	MOULIDHARAN	B.E-EEE	/	/
16	731614105057	SIVAGURU U	B.E-EEE	/	/
17	731614105310	RAJ KUMAR G K	B.E-EEE	/	/
18	731614105312	THIRUMOORTHIG	B.E-EEE	/	/
19	731614106047	NANDHINI R	B.E-ECE	/	/
20	731614106301	DEEPAN K	B.E-ECE	/	/
21	731614106303	DINESH T	B.E-ECE	/	/
22	731614114072	A.LOGESHKUMAR	B.E-MECH	/	/
23	731614114092	MUNIRAJ R	B.E-MECH	/	/
24	731614114315	S.MANJUNATH	B.E-MECH	/	/
25	731614105009	DHIVAGARA	B.E-EEE	/	/
26	731614105034	MOTHINATH	B.E-EEE	/	/
27	731614106008	DEEPANKUMARS	B.E-ECE	/	/
28	731614106053	POONGODI S	B.E-ECE	/	/
29	731614106072	SINEHA N	B.E-ECE	/	/
30	731614114004	AJITHKUMAR.M	B.E-MECH	/	/
31	731614114329	P.VENKATESH	B.E-MECH	/	/
32	731614106016	GOPIKA N	B.E-ECE	/	/
33	731614106022	JAYASHREE	B.E-ECE	/	/
34	731614106068	SASITHA M	B.E-ECE	/	/

PRINCIPAL,  
K. S. R. INSTITUTE FOR  
ENGINEERING AND TECHNOLOGY,  
K. S. R. KALDI NAGAR,  
TIRUCHENGODE - 637 215,  
NAMAKKAL, TAMIL NADU.

## Training and Placement Cell

## SIX PHASE TRAINING PROGRAMME - PHASE - 1

BATCH : 2014 - 2018

Academic Year: 2017 - 2018

Sem: IV / VII

BATCH - 4

Staff Incharge:

S.No.	Reg No.	Name	Dept	26.07.2017	
				FN	AN
35	731614114079	MEIPRAKASH.K	B.E-MECH	A	A
36	731614114331	VIVEKKUMAR G	B.E-MECH	1	1
37	731614205008	PAVITHRA	B.TECH-IT	1	1
38	731614104037	SELVAGANAPATHI.R	B.E-CSE	1	1
39	731614106019	JANANI R	B.E-ECE	1	1
40	731614114064	KAVIYARASU	B.E-MECH	1	1
41	731614205001	N, GNANASEKAR	B.TECH-IT	1	1
42	731614205306	VINITHA K	B.TECH-IT	A	A
43	731614205303	GOKUL K	B.TECH-IT	1	1
44	731614104029	RAKUL M	B.E-CSE	1	1
45	731614105007	BOOPATHI RAJAN S	B.E-EEE	1	1
46	731614106002	Aravind K	B.E-ECE	1	1
47	731614106040	Madhukrishna B	B.E-ECE	1	1
48	731614106066	Santhosh E	B.E-ECE	1	1
49	731614114090	Muhilarasu S	B.E-MECH	1	1
50	731614114155	Velmurugan M	B.E-MECH	1	1
51	731614114313	Logesh A	B.E-MECH	1	1
52	731614114701	Shankarram R	B.E-MECH	1	1
53	731614114317	C Naveen	B.E-MECH	1	1
PRESENT				50	50
ABSENT				1	1
PERMISSION				2	2
OD					

## Session

Theory

Practice

## Timingis

FN: 09:15 to 12:30

AN: 01:30 to 04:45

## Venue

102

Language Lab

## Practice Lab

01:30 - 02:30

02:30 - 03:00

## Practice Lab

03:15 - 04:15

04:15 - 04:45

## Session - I

Test - 01 Hour

Discussion- 30 Mints

## Session - II

Test - 01 Hour

Discussion- 30 Mints

## Tpoic

App + Verbal

## Tpoic

App + Verbal

  
 PRINCIPAL,  
 K. S. R. INSTITUTE FOR  
 ENGINEERING AND TECHNOLOGY,  
 K. S. R. KALVI NAGAR,  
 TIRUCHENGODE - 637 215,  
 NAMAKKAL Dt, TAMIL NADU.



**Training and Placement Cell**  
**SIX PHASE TRAINING PROGRAMME - PHASE - 1**

BATCH : 2014 - 2018

Academic Year: 2017 - 2018

Sem: IV / VII

BATCH - 4

Staff Incharge:

ECE

S.No.	Reg No.	Name	Dept	27.07.2017		28.07.2017		29.07.2017	
				FN	AN	FN	AN	FN	AN
1	731614105073	N.VIJAYAN	B.E-EEE	/	/	/	/	/	/
2	731614105077	V.YUVARAJ	B.E-EEE	/	/	/	/	/	a
3	731614106007	DEEPAKRAJU C	B.E-ECE	/	/	/	/	/	/
4	731614106035	KOWSALYA.M	B.E-ECE	/	/	/	/	/	/
5	731614106049	OVIYA T	B.E-ECE	/	/	/	/	/	/
6	731614106077	SUBATHRA S	B.E-ECE	/	/	/	/	/	/
7	731614106311	UDHAYAKUMAR B	B.E-ECE	/	/	/	/	/	/
8	731614114027	DEEPANCHAKRAVARTHIS	B.E-MECH	/	/	/	/	a	a
9	731614114055	KAMALAKANNAN	B.E-MECH	/	/	/	/	a	a
10	731614114057	KARTHICK.P	B.E-MECH	/	/	/	a	a	a
11	731614114152	K.THIRULOGA SNTHAR	B.E-MECH	/	a	a	a	/	/
12	731614114154	VASANTH S	B.E-MECH	/	/	/	/	/	/
13	731614114314	D.MADHAN RAJ	B.E-MECH	/	/	/	/	/	/
14	731614104033	SARAVANA ABISHEK.G	B.E-CSE	/	a	a	a	a	a
15	731614105035	MOULIDHARAN	B.E-EEE	/	/	/	/	a	a
16	731614105057	SIVAGURU U	B.E-EEE	/	/	/	/	/	a
17	731614105310	RAJ KUMAR G K	B.E-EEE	a	a	/	/	/	/
18	731614105312	THIRUMOORTHIG	B.E-EEE	/	a	/	/	a	a
19	731614106047	NANDHINI R	B.E-ECE	/	/	/	/	/	/
20	731614106301	DEEPAN K	B.E-ECE	/	/	/	/	/	/
21	731614106303	DINESH T	B.E-ECE	/	/	/	/	/	/
22	731614114072	A.LOGESHKUMAR	B.E-MECH	/	/	/	/	/	/
23	731614114092	MUNIRAJ R	B.E-MECH	/	/	/	/	/	/
24	731614114315	S.MANJUNATH	B.E-MECH	a	a	/	/	/	/
25	731614105009	DHIVAGAR A	B.E-EEE	/	/	/	/	/	/
26	731614105034	MOTHINATH	B.E-EEE	/	/	/	/	a	a
27	731614106008	DEEPANKUMAR.S	B.E-ECE	/	/	/	/	/	/
28	731614106053	POONGODI S	B.E-ECE	/	/	/	/	/	/
29	731614106072	SINEHA N	B.E-ECE	/	/	/	/	a	a
30	731614114004	AJITHKUMAR.M	B.E-MECH	/	a	/	/	/	/
31	731614114329	P.VENKATESH	B.E-MECH	/	/	/	/	/	/
32	731614106016	GOPIKA N	B.E-ECE	/	/	/	/	/	/
33	731614106022	JAYASHREE	B.E-ECE	/	/	/	/	/	/
34	731614106068	SASITHA M	B.E-ECE	/	/	/	/	/	/

  
**PRINCIPAL,**  
**K. S. R. INSTITUTE FOR**  
**ENGINEERING AND TECHNOLOGY,**  
**P. O. R. NADYKAR,**  
**CHENNAI - 607 215,**  
**TAMIL NADU.**

**Training and Placement Cell**  
**SIX PHASE TRAINING PROGRAMME - PHASE - 1**

BATCH : 2014 - 2018

Academic Year: 2017 - 2018

Sem: IV / VII

BATCH - 4

Staff Incharge:

ECE

S.No.	Reg No.	Name	Dept	27.07.2017		28.07.2017		29.07.2017	
				FN	AN	FN	AN	FN	AN
35	731614114079	MEIPRAKASH.K	B.E-MECH	/	/	/	/	/	/
36	731614114331	VIVEKKUMAR G	B.E-MECH	/	/	/	/	/	/
37	731614205008	PAVITHRA	B.TECH-IT	/	/	/	/	/	/
38	731614104037	SELVAGANAPATHI.R	B.E-CSE	/	/	/	/	a	a
39	731614106019	JANANI R	B.E-ECE	/	/	/	/	/	/
40	731614114064	KAVIYARASU	B.E-MECH	/	/	/	/	/	/
41	731614205001	N, GNANASEKAR	B.TECH-IT	a	a	/	/	/	/
42	731614205306	VINITHA K	B.TECH-IT	/	/	a	a	/	/
43	731614205303	GOKUL K	B.TECH-IT	/	/	/	/	a	a
44	731614104029	RAKUL M	B.E-CSE	/	/	/	/	/	/
45	731614105007	BOOPATHI RAJAN S	B.E-EEE	/	/	/	/	a	a
46	731614106002	Aravind K	B.E-ECE	a	a	a	a	a	a
47	731614106040	Madhukrishna B	B.E-ECE	/	/	/	/	/	/
48	731614106056	Santhosh E	B.E-ECE	/	/	/	/	/	/
49	731614114090	Muhilarasu S	B.E-MECH	/	/	/	/	a	a
50	731614114155	Velmurugan M	B.E-MECH	/	/	a	a	a	a
51	731614114313	Logesh A	B.E-MECH	/	/	/	/	a	a
52	731614114701	Shankarram R	B.E-MECH	/	/	/	/	/	/
53	731614114317	C Naveen	B.E-MECH	/	/	/	/	/	/
54	731614104307	P. PUGIAL MANI	B.E-MECH	/	/	/	/	a	a
PRESENT									
ABSENT									
PERMISSION									
OD									

Session  
Practice  
Theory

Timingis

FN: 09:15 to 12:30  
AN: 01:30 to 04:45

Venue

Language Lab  
102

Break Timings

FN: 10:45 to 11:00  
AN: 03:00 to 03:15

Practice Lab  
09:15 - 10:15  
10:15 - 10:45  
Practice Lab  
11:00 - 12:00  
12:00 - 12:30

Session - I  
Test - 01 Hour  
Discussion- 30 Mints  
Session - II  
Test - 01 Hour  
Discussion- 30 Mints

Tpoic  
App + Verbal

Tpoic  
App + Verbal

  
**PRINCIPAL,**  
**K. S. R. INSTITUTE FOR**  
**ENGINEERING AND TECHNOLOGY,**  
**K. S. R. KALVI NAGAR,**  
**TIRUCHENGODE - 637 215,**  
**KARNATAKA Dt, TAMIL NADU.**

TRAINING & PLACEMENT CELL - Six Phrase Training Programme



BATCH: 2014 - 2018

ACADEMIC YEAR: 2016 - 2017 (Even)

DATE: 27.07.2017

Fore Noon session

S.NO	BRANCH	Non PRP				PRP			
		STRENGTH	PRESENT	ABSENT	LEAVE	STRENGTH	PRESENT	ABSENT	LEAVE
1	CSE	12	11	0	1	12	12	0	0
2	ECE - A & B	50	49	0	1	18	18	0	0
3	EEE - A & B	30	29	0	1	19	19	0	0
4	IT	7	6	1	0	5	5	0	0
5	MECH A, B & C	117	113	2	2	NA	NA	NA	NA
<b>Total</b>		<b>216</b>	<b>208</b>	<b>3</b>	<b>5</b>	<b>54</b>	<b>54</b>	<b>0</b>	<b>0</b>

After Noon Session

S.NO	BRANCH	Non PRP				PRP			
		STRENGTH	PRESENT	ABSENT	LEAVE	STRENGTH	PRESENT	ABSENT	LEAVE
1	CSE	12	11	0	1	12	12	0	0
2	ECE - A & B	50	49	0	1	18	18	0	0
3	EEE - A & B	30	29	0	1	19	19	0	0
4	IT	7	6	1	0	5	5	0	0
5	MECH A, B & C	117	113	2	2	NA	NA	NA	NA
<b>Total</b>		<b>216</b>	<b>208</b>	<b>3</b>	<b>5</b>	<b>54</b>	<b>54</b>	<b>0</b>	<b>0</b>

*F. Kalvi*  
TRP officer

*[Signature]*  
TRP Coordinator

*[Signature]*  
Principal

PRINCIPAL,  
K. S. R. INSTITUTE FOR  
ENGINEERING AND TECHNOLOGY,  
K. S. R. KALVI NAGAR,  
TIRUCHENGODE - 637 215,  
NAMAKKAL Dt, TAMIL NADU.

Fore Noon session

S.NO	BRANCH	STRENGTH	No of Placement Registered Students	Gate Registered	PRESENT	ABSENT	LEAVE
1	CSE	51	23	1	23	0	1
2	ECE - A	52	39	3	40	1	1
3	ECE - B	47	23	3	23	1	2
4	EEE - A	41	27	0	27	0	0
5	EEE - B	40	22	0	22	0	0
6	IT	16	11	1	11	0	1
7	MECH - A	68	47	0	45	1	1
8	MECH - B	66	41	0	39	1	1
9	MECH - C	56	31	0	27	0	4
<b>Total</b>		<b>437</b>	<b>264</b>	<b>8</b>	<b>257</b>	<b>4</b>	<b>11</b>

After Noon Session

S.NO	BRANCH	STRENGTH	No of Placement Registered Students	Gate Registered	PRESENT	ABSENT	LEAVE
1	CSE	51	23	1	23	0	1
2	ECE - A	52	39	3	40	1	1
3	ECE - B	47	23	3	23	1	2
4	EEE - A	41	27	0	27	0	0
5	EEE - B	40	22	0	22	0	0
6	IT	16	11	1	11	0	1
7	MECH - A	68	47	0	45	1	1
8	MECH - B	66	41	0	39	1	1
9	MECH - C	56	31	0	26	1	4
<b>Total</b>		<b>437</b>	<b>264</b>	<b>8</b>	<b>256</b>	<b>5</b>	<b>11</b>

*Kalvi*  
T&P Officer

*[Signature]*

*[Signature]*  
T&P Coordinator

*[Signature]*  
Principal

PRINCIPAL,  
K. S. R. INSTITUTE FOR  
ENGINEERING AND TECHNOLOGY,  
K. S. R. KALVI NAGAR,  
TIRUCHENGODE - 637 215,  
NAMAKKAL DISTRICT, TAMIL NADU.

**TRAINING & PLACEMENT CELL - Six Phrase Training Programme**



BATCH: 2014 - 2018

ACADEMIC YEAR: 2016 - 2017 (Even)

DATE: 28.07.2017

**Fore Noon session**

S.NO	BRANCH	Non PRP				PRP			
		STRENGTH	PRESENT	ABSENT	LEAVE	STRENGTH	PRESENT	ABSENT	LEAVE
1	CSE	12	12	0	0	12	12	0	0
2	ECE - A & B	50	48	0	2	18	18	0	0
3	EEE - A & B	30	30	0	0	19	19	0	0
4	IT	7	6	1	0	5	5	0	0
5	MECH A, B & C	117	113	2	2	NA	NA	NA	NA
<b>Total</b>		<b>216</b>	<b>209</b>	<b>3</b>	<b>4</b>	<b>54</b>	<b>54</b>	<b>0</b>	<b>0</b>

**After Noon Session**

S.NO	BRANCH	Non PRP				PRP			
		STRENGTH	PRESENT	ABSENT	LEAVE	STRENGTH	PRESENT	ABSENT	LEAVE
1	CSE	12	12	0	0	12	12	0	0
2	ECE - A & B	50	48	0	2	18	18	0	0
3	EEE - A & B	30	30	0	0	19	19	0	0
4	IT	7	6	1	0	5	5	0	0
5	MECH A, B & C	117	112	3	2	NA	NA	NA	NA
<b>Total</b>		<b>216</b>	<b>208</b>	<b>4</b>	<b>4</b>	<b>54</b>	<b>54</b>	<b>0</b>	<b>0</b>

*Y. K. K. H. H.*  
T&P officer

*T. P. S. S. S. S.*  
T&P coordinator

*S. S. S. S.*  
Principal

  
**PRINCIPAL,**  
**K. S. R. INSTITUTE FOR**  
**ENGINEERING AND TECHNOLOGY,**  
**K. S. R. KALSI NAGAR,**  
**TIRUCHENGODE - 637 215,**  
**NAMAKKAL DISTRICT, TAMIL NADU.**

**TRAINING & PLACEMENT CELL - Six Phase Training Programme**



BATCH: 2014 - 2018

ACADEMIC YEAR: 2016 - 2017 (Even)

DATE: 29.07.2017

**Fore Noon session**

S.NO	BRANCH	Non PRP				PRP			
		STRENGTH	PRESENT	ABSENT	LEAVE	STRENGTH	PRESENT	ABSENT	LEAVE
1	CSE	12	9	3	0	12	12	0	0
2	ECE - A & B	50	45	1	4	18	18	0	0
3	EEE - A & B	30	24	5	1	19	17	1	1
4	IT	7	5	1	1	5	5	0	0
5	MECH A, B & C	117	106	7	4	NA	NA	NA	NA
<b>Total</b>		<b>216</b>	<b>189</b>	<b>17</b>	<b>10</b>	<b>54</b>	<b>52</b>	<b>1</b>	<b>1</b>

S.NO	BRANCH	Non PRP				PRP			
		STRENGTH	PRESENT	ABSENT	LEAVE	STRENGTH	PRESENT	ABSENT	LEAVE
1	CSE	12	9	3	0	12	11	1	0
2	ECE - A & B	50	45	1	4	18	18	0	0
3	EEE - A & B	30	22	7	1	19	17	1	1
4	IT	7	5	1	1	5	5	0	0
5	MECH A, B & C	117	102	11	4	NA	NA	NA	NA
<b>Total</b>		<b>216</b>	<b>183</b>	<b>23</b>	<b>10</b>	<b>54</b>	<b>51</b>	<b>2</b>	<b>1</b>

*T & P Officer*



*T & P Coordinator*

*Principal*

**PRINCIPAL,**  
**K. S. R. INSTITUTE FOR**  
**ENGINEERING AND TECHNOLOGY,**  
**K. S. R. KALVINAGAR,**  
**TIRUCHENGURU - 607 213,**  
**NAMAKKAL DISTRICT, TAMIL NADU.**

TRAINING PROGRAMME FEEDBACK FORM

Name of the Student: P. Siva Ranjani

Branch: B. ECE

Year / Sem: (V / VI)

4. Name of the Training: Reasoning

5. Name of the Trainer: Santhosh

6. Students rating of Trainers :

S. No.	Date	Subject	Rating (✓)			
			Excellent	Very good	Good	Average
1	26.7.17	Data Arrangement Data Sufficiency cube, Cuboid	✓			

4. Two positive points about the programme:

His way of teaching is good, clear explanation

5. Suggestions for improvement:

Date: 26.7.17

P. Siva Ranjani  
Signature

  
PRINCIPAL,  
K. S. R. INSTITUTE FOR  
ENGINEERING AND TECHNOLOGY,  
K. S. R. KALVI NAGAR,  
TIRUCHENGODE - 637 215,  
NAMAKKAL DI, TAMIL NADU.

**K S R INSTITUTE FOR ENGINEERING AND TECHNOLOGY  
TIRUCHENGODE - 637 215**

**TRAINING PROGRAMME FEEDBACK FORM**



Name of the Student: S. K. Arun

Branch: ECB

Year / Sem: IV /

1. Name of the Training : Apkade

2. Name of the Trainer : Sathish Kumar

3. Students rating of Trainers :

S. No.	Date	Subject	Rating (√)			
			Excellent	Very good	Good	Average
1	26/9/17	Probability - Calc Cramer's		✓		

4. Two positive points about the programme:

*Good explanation  
shortcut methods*

5. Suggestions for improvement:

*Nil*

Date: 26.9.17

*S. K. Arun*  
Signature

**K S R INSTITUTE FOR ENGINEERING AND TECHNOLOGY  
TIRUCHENGODE - 637 215**

**TRAINING PROGRAMME FEEDBACK FORM**



Name of the Student: C. Logarathan

Branch: ECB

Year / Sem:

4. Name of the Training :

5. Name of the Trainer : Sathish Kumar

6. Students rating of Trainers :

S. No.	Date	Subject	Rating (√)			
			Excellent	Very good	Good	Average
1	26/9/17	Percentage & Ratio Algebra		✓		

4. Two positive points about the programme:

*Good explanation*

5. Suggestions for improvement:

*Nil*

Date: 26/9/17

PRINCIPAL,  
K S R INSTITUTE FOR  
ENGINEERING AND TECHNOLOGY,  
K. S. R. KALVI NAGAR,  
TIRUCHENGODE - 637 215,  
KARNATAKA, TAMIL NADU.

*C. Logarathan*  
Signature



K S R INSTITUTE FOR ENGINEERING AND TECHNOLOGY  
TIRUCHENGODE - 637 215



TRAINING PROGRAMME FEEDBACK FORM

Section - A  
FN.

Name of the Student: S. KARTHIKEYAN

Branch: MECHANICAL

Year / Sem: IV / 07

1. Name of the Training: Appitude (Reasoning, verbal)

2. Name of the Trainer: Krishna & sharmila.

3. Students rating of Trainers :

S. No.	Date	Subject	Rating (√)			
			Excellent	Very good	Good	Average
1	26.07.17	Reasoning (Number) verbal		✓		

4. Two positive points about the programme:

Fulfill the topic

Easily all problem are solved

5. Suggestions for improvement:

Verbal session they can not give

Date: Short cut and root words.

26.07.17

Signature

S. Karthikeyan

K S R INSTITUTE FOR ENGINEERING AND TECHNOLOGY  
TIRUCHENGODE - 637 215



TRAINING PROGRAMME FEEDBACK FORM

Section - A  
FN

Name of the Student: V. Harish

Branch: Mechanical

Year / Sem: IV / 07

4. Name of the Training: online test

5. Name of the Trainer :

6. Students rating of Trainers :

S. No.	Date	Subject	Rating (√)			
			Excellent	Very good	Good	Average
1	26.07.17			✓		

4. Two positive points about the programme:

Time management in online test

5. Suggestions for improvement:



Date: 26.07.17

PRINCIPAL,  
K. S. R. INSTITUTE FOR  
ENGINEERING AND TECHNOLOGY,  
K. S. R. KALVI NAGAR,  
TIRUCHENGODE - 637 215,  
NARAYAL DI, TAMIL NADU.

V. Harish

Signature

**K S R INSTITUTE FOR ENGINEERING AND TECHNOLOGY  
TIRUCHENGODE - 637 215**

**TRAINING PROGRAMME FEEDBACK FORM**



Section-C  
FN-I

Name of the Student: MUDALIYAR VISHNUPARASURAMAN Branch: MECHANICAL

Year / Sem: IV / VII

1. Name of the Training : Verbal - synonyms

2. Name of the Trainer : Krishna

3. Students rating of Trainers :

S. No.	Date	Subject	Rating (√)			
			Excellent	Very good	Good	Average
1	26.7.17				✓	

4. Two positive points about the programme:

Good sentence making

5. Suggestions for improvement: NIL

Date: 26-6-17

[Signature]  
Signature

**K S R INSTITUTE FOR ENGINEERING AND TECHNOLOGY  
TIRUCHENGODE - 637 215**

**TRAINING PROGRAMME FEEDBACK FORM**



Section-C  
FN-II

Name of the Student: MADAN KANSAJID Branch: MECH

Year / Sem:

4. Name of the Training : Aptitude

5. Name of the Trainer : chaimila

6. Students rating of Trainers :

S. No.	Date	Subject	Rating (√)			
			Excellent	Very good	Good	Average
1	26.7.17	Roots, square <u>shortcuts for multiplication</u>			✓	

4. Two positive points about the programme:

can be able to solve Aptitude easily  
and also able to solve pblms with in time

5. Suggestions for improvement:

Well about aptitudes & shortcuts

Date: 26-7-17

PRINCIPAL  
**K. S. R. INSTITUTE FOR  
ENGINEERING AND TECHNOLOGY,  
K. S. R. KALVI NAGAR,  
TIRUCHENGODE - 637 215,  
KANNAMALAI, TAMIL NADU.**

[Signature]  
Signature

K S R INSTITUTE FOR ENGINEERING AND TECHNOLOGY  
TIRUCHENGODE - 637 215



TRAINING PROGRAMME FEEDBACK FORM

Section-B  
F.N-I

Name of the Student: M. Ranjith kumar

Branch: Mechanics

Year / Sem: IV / B - 7<sup>th</sup> sem.

1. Name of the Training: Verbal -

2. Name of the Trainer: Krishna

3. Students rating of Trainers :

S. No.	Date	Subject	Rating (√)			
			Excellent	Very good	Good	Average
1	26-7-2017	Synonyms.			✓	

4. Two positive points about the programme:

(\*) Good Communication Skill. (\*)

5. Suggestions for improvement:

(\*) It will be very helpful, if they give shortcuts for identifying synonyms.

Date: 26-7-2017

Signature M. Rajan

K S R INSTITUTE FOR ENGINEERING AND TECHNOLOGY  
TIRUCHENGODE - 637 215



TRAINING PROGRAMME FEEDBACK FORM

Section-B  
F.N-II

Name of the Student: S. Muhilarasu

Branch: Mechanical

Year / Sem: IV / B - 7<sup>th</sup> sem.

4. Name of the Training: Numbers.

5. Name of the Trainer: S. Harimila

6. Students rating of Trainers :

S. No.	Date	Subject	Rating (√)			
			Excellent	Very good	Good	Average
1	26-7-17.	Numbers Divisibility Squaring.	✓			

4. Two positive points about the programme:

\* Good Teaching & And how to solve problems in Easy Methods.

5. Suggestions for improvement:

\* Try to give more Interested Topics.

Date: 26.7.17.

Signature S. Harimila

K S R INSTITUTE FOR ENGINEERING AND TECHNOLOGY  
TIRUCHENGODE - 637 215

Section - B  
AN

TRAINING PROGRAMME FEEDBACK FORM



Name of the Student: S. SANJ PRAKASH

Branch: MECHANICAL

Year / Sem: IV / 7

1. Name of the Training: SINDHU

2. Name of the Trainer: PLACEMENT TRAINING

3. Students rating of Trainers :

S. No.	Date	Subject	Rating (✓)			
			Excellent	Very good	Good	Average
1	26.07.2017	Verbal Reasoning (online test)	✓			

4. Two positive points about the programme:

- (i) It is helpful and also develops our skills.
- (ii) Questions are easy to understand.

5. Suggestions for improvement:

- (i) There is no suggestion.

Date: 26.7.2017

Signature

K S R INSTITUTE FOR ENGINEERING AND TECHNOLOGY  
TIRUCHENGODE - 637 215

Section - C  
AN

TRAINING PROGRAMME FEEDBACK FORM



Name of the Student: S. Vasanth

Branch: MECHANICAL

Year / Sem: IV / 7

4. Name of the Training: SINDHU

5. Name of the Trainer: PLACEMENT TRAINING

6. Students rating of Trainers :

S. No.	Date	Subject	Rating (✓)			
			Excellent	Very good	Good	Average
1	26.7.17	Verbal Reasoning (online test)		✓		

4. Two positive points about the programme:

- 1) This question to improve our aptitude skills
- 2) Many test are placed to develop our knowledge.

5. Suggestions for improvement:

Date: 26.7.17

PRINCIPAL,  
K S R INSTITUTE FOR  
ENGINEERING AND TECHNOLOGY,  
K. S. R. KALVI NAGAR,  
TIRUCHENGODE - 637 215,  
NARAKKAL DI, TAMIL NADU.

Signature



(F.N - 102)

Name of the Student: M. Goya

Branch: Mechanical

Year / Sem:

1. Name of the Training : APTITUDE Reasoning

2. Name of the Trainer : Krishna

3. Students rating of Trainers :

S. No.	Date	Subject	Rating (✓)			
			Excellent	Very good	Good	Average
1	27.7.17	APT - Permutation, Combination Data Sufficiency Verbal - Complete sentence			✓	

4. Two positive points about the programme:

- Better than yesterday
- more no. of questions solved

5. Suggestions for improvement:

can give more input

[Signature]  
Signature

Date: 27.7.17



Name of the Student: ARVI PRAKASH P

Branch: MECHANICAL

Year / Sem: IV / VII

1. Name of the Training : Verbal [choose the best option]

2. Name of the Trainer : Krishanand

3. Students rating of Trainers : 100

S. No.	Date	Subject	Rating (✓)			
			Excellent	Very good	Good	Average
1	27.7.17	Verbal		✓		

4. Two positive points about the programme:

- (i) Easy to understand
- (ii) Explanation is good.

5. Suggestions for improvement:

(i) need to make more interesting.

Date: 27.07.2017

PRINCIPAL,  
K. S. R. KALVI NAGAR,  
TIRUCHENGODE - 637 215,  
TAMIL NADU.

[Signature]  
Signature



TRAINING PROGRAMME FEEDBACK FORM

Name of the Student: S. V. DINESH

Branch: MECHANICAL

Year / Sem: IV / 07

4. Name of the Training: Permutation and combination

5. Name of the Trainer: Sharmila

6. Students rating of Trainers :

S. No.	Date	Subject	Rating (✓)			
			Excellent	Very good	Good	Average
1	27/7/17	P&C Permutation & combination	✓			

4. Two positive points about the programme:

It is easy to understand.

5. Suggestions for improvement:

Improve the teaching method

Date: 27/7/17

S. V. Dinesh  
Signature



TRAINING PROGRAMME FEEDBACK FORM

Name of the Student: M. Dinesh Kumar

Branch: Mechanics

Year / Sem: Final / Seventh

1. Name of the Training: Permutation & Combination

2. Name of the Trainer: Sharmila

3. Students rating of Trainers :

S. No.	Date	Subject	Rating (✓)			
			Excellent	Very good	Good	Average
1	27/7/17	Combination		✓		

4. Two positive points about the programme:

Learn how to calculate the combination & Permutation

5. Suggestions for improvement:

Improve the teaching Method.

Date: 27/7/17

PRINCIPAL,  
K S R INSTITUTE FOR  
ENGINEERING AND TECHNOLOGY,  
K. S. P. TALKI NAGAR,  
TIRUCHENGODE - 637 215,  
TAMIL NADU.

M. Dinesh Kumar  
Trainer  
Signature

K S R INSTITUTE FOR ENGINEERING AND TECHNOLOGY  
TIRUCHENGODE - 637 215

TRAINING PROGRAMME FEEDBACK FORM



Name of the Student: M. Sowthinya

Branch: B.Tech - IT

Year / Sem: IV / VI

1. Name of the Training: Karthikayan

2. Name of the Trainer: Aptitude (Quantz)

3. Students rating of Trainers :

S. No.	Date	Subject	Rating (✓)			
			Excellent	Very good	Good	Average
1	27.7.17	Numbers	✓			

4. Two positive points about the programme:

- \* To give a more shortcuts to solve a problem.
- \* To solved many problem.

5. Suggestions for improvement:

-

Date: 27.7.17

M. P. L.  
Signature

K S R INSTITUTE FOR ENGINEERING AND TECHNOLOGY  
TIRUCHENGODE - 637 215

TRAINING PROGRAMME FEEDBACK FORM



Name of the Student: J. KARTHIK RAJA

Branch: C.S.E

Year / Sem:

4. Name of the Training: Permutation & combination.

5. Name of the Trainer :

6. Students rating of Trainers :

S. No.	Date	Subject	Rating (✓)			
			Excellent	Very good	Good	Average
1	27.7.17	ONLINE TEST PERMUTATION			✓	

4. Two positive points about the programme:

- It is good to improve our skills and known about the shortcuts.

5. Suggestions for improvement:

- Please give the ideas to observe their concepts and contents to about the concepts.

Date:

27.07.17.

KSRIET  
ENGINEERING AND TECHNOLOGY,  
K. S. R. KALUS NAGAR,  
TIRUCHENGODE - 637 215,  
N. DISTRICT, TAMIL NADU.

Signature

J. Karthik Raja

K S R INSTITUTE FOR ENGINEERING AND TECHNOLOGY  
TIRUCHENGODE - 637 215

TRAINING PROGRAMME FEEDBACK FORM



Name of the Student: S. SUGUMAR Branch: ECE

Year / Sem: IV / 06

1. Name of the Training: QUANTITATIVE APPITUDE

2. Name of the Trainer: KARTHIKEYAN

3. Students rating of Trainers :

S. No.	Date	Subject	Rating (√)			
			Excellent	Very good	Good	Average
1	27/7/17	QUANTZ (Time & Work)		✓		

4. Two positive points about the programme:

\* EASY TO UNDERSTAND

\* GOOD LOGICAL ABILITY.

5. Suggestions for improvement:

Nil

Date: 27 JUL 2017

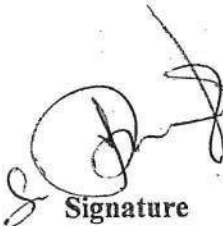
  
Signature

K S R INSTITUTE FOR ENGINEERING AND TECHNOLOGY  
TIRUCHENGODE - 637 215

TRAINING PROGRAMME FEEDBACK FORM



Name of the Student: S. KEERTHANA Branch: ECE

Year / Sem: IV / 06

4. Name of the Training: QUANTITATIVE APPITUDE.

5. Name of the Trainer: KARTHIKEYAN

6. Students rating of Trainers :

S. No.	Date	Subject	Rating (√)			
			Excellent	Very good	Good	Average
1	27/7/17	QUANTZ Simple & compound profit, loss, percentage.		✓		

4. Two positive points about the programme:

\* Explained more number of ways to solve a problem

\* Easy to solve problems

5. Suggestions for improvement:

Date: 27 / 7 / 17

PRINCIPAL  
K. S. R. INSTITUTE FOR  
ENGINEERING AND TECHNOLOGY,  
K. S. R. KALAI NAGAR,  
TIRUCHENGODE - 637 215,  
TAMIL NADU.

  
Signature





Name of the Student: Partha Sarathi, M.M Branch: ECE

Year / Sem: IV / VII

4. Name of the Training: Permutation & Combination and Numbers

5. Name of the Trainer: Sindhu

6. Students rating of Trainers :

S. No.	Date	Subject	Rating (✓)			
			Excellent	Very good	Good	Average
1	27/7/17	Numbers Permutation & Comb.		✓		

4. Two positive points about the programme:

(i) Clarity of explanation is good (ii) Way of understanding is easy.

5. Suggestions for improvement:

—

Date: 27/7/17

Parthasarthy  
Signature



Name of the Student: M. HEMAVARTHINI Branch: B.E, ECE

Year / Sem: IV / VII

4. Name of the Training: Appitude (Quantz)

5. Name of the Trainer: M. Karthikeyan

6. Students rating of Trainers :

S. No.	Date	Subject	Rating (✓)			
			Excellent	Very good	Good	Average
1	27.7.17	permutation, combination, probability	✓			

4. Two positive points about the programme:

\* Solved many problems logically.  
\* Developed logical thinking.

5. Suggestions for improvement:

No suggestions

Date: 27.7.17

PRINCIPAL,  
K. S. R. INSTITUTE FOR  
ENGINEERING AND TECHNOLOGY,  
K. S. R. KALVI NAGAR,  
TIRUCHENGODE - 637 215,  
KANNAKAL, TAMIL NADU.

Parthasarthy  
Signature

K S R INSTITUTE FOR ENGINEERING AND TECHNOLOGY  
TIRUCHENGODE - 637 215

TRAINING PROGRAMME FEEDBACK FORM



Name of the Student: S. Nanthan Kumar

Branch: B.Tech. E.T.

Year / Sem: VI - Final Year - VI

1. Name of the Training: Time & work, Area Square, multiplication

2. Name of the Trainer: Karthikeyan

3. Students rating of Trainers: 10

S. No.	Date	Subject	Rating (✓)			
			Excellent	Very good	Good	Average
1	27.7.17	Time & work	✓			

4. Two positive points about the programme:

He teach well

5. Suggestions for improvement:

No suggestion

Date:

S. Nanthan Kumar  
Signature

K S R INSTITUTE FOR ENGINEERING AND TECHNOLOGY  
TIRUCHENGODE - 637 215

TRAINING PROGRAMME FEEDBACK FORM



Name of the Student: S. Thakkiya

Branch: B.Tech - IT

Year / Sem: Final Year / VII

4. Name of the Training: Simple Interest, Compound Interest, Profit & Loss

5. Name of the Trainer: Karthikeyan

6. Students rating of Trainers: 10

S. No.	Date	Subject	Rating (✓)			
			Excellent	Very good	Good	Average
1	27.7.17	Profit & Loss		✓		

4. Two positive points about the programme:

easy to understand

5. Suggestions for improvement:

No suggestions

Date: 27.7.17

K S R INSTITUTE FOR  
ENGINEERING AND TECHNOLOGY,  
K. S. R. KALVI NAGAR,  
TIRUCHENGODE - 637 215,  
NAMAKKAL DISTRICT, TAMIL NADU.

[Signature]  
Signature

K S R INSTITUTE FOR ENGINEERING AND TECHNOLOGY  
TIRUCHENGODE - 637 215

TRAINING PROGRAMME FEEDBACK FORM



Name of the Student: S Tarun chouban Branch: Mechanical

Year / Sem: IV / 7<sup>th</sup>

1. Name of the Training : Permutation, Combination, Reasoning

2. Name of the Trainer : Sharmi/a

3. Students rating of Trainers : 8/10

S. No.	Date	Subject	Rating (✓)			
			Excellent	Very good	Good	Average
1	27/07/17	Combination.			✓	

4. Two positive points about the programme: Good.

5. Suggestions for improvement: NIL

Date: 27/07/17

S. T. L.  
Signature

K S R INSTITUTE FOR ENGINEERING AND TECHNOLOGY  
TIRUCHENGODE - 637 215

TRAINING PROGRAMME FEEDBACK FORM



Name of the Student: G. Mithun Chakravarthy Branch: Mechanical

Year / Sem: IV / 7<sup>th</sup>

4. Name of the Training :

5. Name of the Trainer : Krishna,

6. Students rating of Trainers : 5/10

S. No.	Date	Subject	Rating (✓)			
			Excellent	Very good	Good	Average
1	27/07/17	Verbal				✓

4. Two positive points about the programme:

5. Suggestions for improvement: NIL

Date: 27/07/17

  
PRINCIPAL,  
K. S. R. INSTITUTE FOR  
ENGINEERING AND TECHNOLOGY,  
K. S. R. KALVI NAGAR,  
TIRUCHENGODE - 637 215,  
NAMAKKAL Dt, TAMIL NADU.

G. Mithun  
Signature

**K S R INSTITUTE FOR ENGINEERING AND TECHNOLOGY  
TIRUCHENGODE - 637 215**

**TRAINING PROGRAMME FEEDBACK FORM**



Name of the Student: S. Thyagarajan Branch: EEE

Year / Sem: IV / 7

1. Name of the Training : Quantitative Aptitude

2. Name of the Trainer : Karthick

3. Students rating of Trainers :

S. No.	Date	Subject	Rating (√)			
			Excellent	Very good	Good	Average
1	27/7/17	Q. Aptitude	✓			

*(Time & work)*

4. Two positive points about the programme:

→ It is Very good training to improve Shortcuts.

5. Suggestions for improvement:

→ want some more time to solve in Problems.

Date:

S. Thyagarajan  
Signature

**K S R INSTITUTE FOR ENGINEERING AND TECHNOLOGY  
TIRUCHENGODE - 637 215**

**TRAINING PROGRAMME FEEDBACK FORM**



Name of the Student: M. Anitha Branch: EEE

Year / Sem: IV / 7

4. Name of the Training : Quantitative Aptitude

5. Name of the Trainer : Karthikeyan

6. Students rating of Trainers :

S. No.	Date	Subject	Rating (√)			
			Excellent	Very good	Good	Average
1	27/7/17	Simple & compound Profit, loss, percentage.	✓			

4. Two positive points about the programme:

It is helpful to improve the approaching question in logical way without formula as well as with formula.

5. Suggestions for improvement:

We need more practice session.

Date: 27/7/17

PRINCIPAL,  
K. S. R. INSTITUTE FOR  
ENGINEERING AND TECHNOLOGY,  
K. S. R. KALVI NAGAR,  
TIRUCHENGODE - 637 215,  
NANDYALPET, TAMIL NADU.

M. Anitha  
Signature

K S R INSTITUTE FOR ENGINEERING AND TECHNOLOGY  
TIRUCHENGODE - 637 215

TRAINING PROGRAMME FEEDBACK FORM



Name of the Student: S. Karthikeyan

Branch: 28-7-17 MECH

Year / Sem: IV/07

1. Name of the Training: Verbal

2. Name of the Trainer: Krishna.

3. Students rating of Trainers :

S. No.	Date	Subject	Rating (✓)			
			Excellent	Very good	Good	Average
1	28-7-17	Antonyms		✓		

4. Two positive points about the programme:

To say the correct meanings  
very clear classes.

5. Suggestions for improvement:

give so many meaning of words with  
examples.

Date:

Signature: S. Karthikeyan

K S R INSTITUTE FOR ENGINEERING AND TECHNOLOGY  
TIRUCHENGODE - 637 215

TRAINING PROGRAMME FEEDBACK FORM



Name of the Student: P. Divya Prabha

Branch: FCE

Year / Sem: IV / 06

1. Name of the Training: odd man series, Geometry & Mensuration, Antonym

2. Name of the Trainer: Sharmila.

3. Students rating of Trainers :

S. No.	Date	Subject	Rating (✓)			
			Excellent	Very good	Good	Average
1	28.7.17	odd man series, Geometry & mensura- -tion, Antonyms.		✓		

4. Two positive points about the programme:

→ In between doing "ice breakers" for Relaxation.

→ clear Explanation

5. Suggestions for improvement:

→ Example sums always should be solved by the students.

Date:

28.7.17

K. S. R. KALVI NAGAR,  
TIRUCHENGODE - 637 215,  
TAMIL NADU

Signature

P. Divya Prabha



TRAINING PROGRAMME FEEDBACK FORM

Name of the Student: A. Sharanya Branch: ECE

Year / Sem: Final / 07

4. Name of the Training: SMART PLACEMENT TRAINING (Appetitude, verbal, reasoning)

5. Name of the Trainer: SINDHU

6. Students rating of Trainers :

S. No.	Date	Subject	Rating (√)			
			Excellent	Very good	Good	Average
1	28/7/17	Verbal, Reasoning, Appetitude			✓	

4. Two positive points about the programme:

The way of teaching is good.

5. Suggestions for improvement:

Need more problems to solve  
A. Dasari

Date: 28/7/17

Signature



TRAINING PROGRAMME FEEDBACK FORM

Name of the Student: R. Jothi Prakash Branch: ECE

Year / Sem: 2 / VII

4. Name of the Training: Scholarship Competition, error spot

5. Name of the Trainer: Krishna Reddy

6. Students rating of Trainers : 10

S. No.	Date	Subject	Rating (√)			
			Excellent	Very good	Good	Average
1	29/7/17	Spot the error	✓			

4. Two positive points about the programme: Voice is audible, Solved the problems in easy manner.

5. Suggestions for improvement: Try to solve only important questions.

Date: 29/7/17

PRINCIPAL,  
K. S. R. INSTITUTE FOR  
ENGINEERING AND TECHNOLOGY,  
K. S. R. KALU NAGAR,  
TIRUCHENGODE - 637 215,  
TAMIL NADU.

[Signature]  
Signature

TRAINING PROGRAMME FEEDBACK FORM

Name of the Student: VIJAY

Branch: IT

Year / Sem: IV/07

4. Name of the Training: Verbal

5. Name of the Trainer: Krishna

6. Students rating of Trainers :

S. No.	Date	Subject	Rating (✓)			
			Excellent	Very good	Good	Average
1	28-7-17	Antonyms	✓			

4. Two positive points about the programme:

Excellent speaker, more words are meaningful.

5. Suggestions for improvement:

More puzzle say the class.

Date:

S. P. A.  
Signature

2/6

TRAINING PROGRAMME FEEDBACK FORM

Hall: 101

Name of the Student: ARAVINDHAN. B

Branch: EEE

Year / Sem: Final / 07

1. Name of the Training: VERBAL

2. Name of the Trainer: KRISHNA.

3. Students rating of Trainers :

S. No.	Date	Subject	Rating (✓)			
			Excellent	Very good	Good	Average
1	28/7/17	VERBAL				✓

4. Two positive points about the programme:

Teaching is good.

5. Suggestions for improvement:

Need more interaction

PRINCIPAL,  
K S R INSTITUTE FOR  
ENGINEERING AND TECHNOLOGY,  
K. S. R. KALVI NAGAR,  
TIRUCHENGODE - 637 215,  
NAGAR.

B. D. A. S.  
Signature

TRAINING PROGRAMME FEEDBACK FORM

Name of the Student: M. Kavin Kumar

Branch: EEE

Year / Sem:

4. Name of the Training: odd man Out (Online Test), Antonyms.

5. Name of the Trainer: Sharmila

6. Students rating of Trainers :

S. No.	Date	Subject	Rating (√)			
			Excellent	Very good	Good	Average
1	28.7.2017	Synonyms, Antonyms			✓	

4. Two positive points about the programme:

Their Explanation was so good.

The concept was understood by us easily.

5. Suggestions for improvement:

We need more examples related to the topic.

Date:

28.7.2017

Signature

M. Kavin Kumar

PRINCIPAL,  
K. S. R. INSTITUTE FOR  
ENGINEERING AND TECHNOLOGY,  
K. S. R. KALVI NAGAR,  
TIRUCHENGODE - 637 215,  
NAMAKKAL Dt, TAMIL NADU.



K S R INSTITUTE FOR ENGINEERING AND TECHNOLOGY  
TIRUCHENGODE - 637 215

TRAINING PROGRAMME FEEDBACK FORM



Name of the Student: KEERAVANIR

Branch: B.E - EEE

Year / Sem: IV / VII

1. Name of the Training : Quants

2. Name of the Trainer : Gomathi

3. Students rating of Trainers :

S. No.	Date	Subject	Rating (✓)			
			Excellent	Very good	Good	Average
1	28/7/17	Quants			✓	

4. Two positive points about the programme: We have solved some problems.  
We learnt some reasoning question.

5. Suggestions for improvement:

R. Kusavan.

Signature

Date: 28.7.17

K S R INSTITUTE FOR ENGINEERING AND TECHNOLOGY  
TIRUCHENGODE - 637 215

TRAINING PROGRAMME FEEDBACK FORM



Name of the Student: M. Lavanya

Branch: B.E - EEE

Year / Sem: IV / VII

4. Name of the Training : Quantitative Aptitude

5. Name of the Trainer : Gomathi

6. Students rating of Trainers :

S. No.	Date	Subject	Rating (✓)			
			Excellent	Very good	Good	Average
1	28/7/17	Quants			✓	

4. Two positive points about the programme: They cleared some doubts for us  
we practised some APPS Questions

5. Suggestions for improvement:

PRINCIPAL,  
K S R INSTITUTE FOR  
ENGINEERING AND TECHNOLOGY,  
K. S. R. KALVI NAGAR,  
TIRUCHENGODE - 637 215,  
NAMAKKAL Dt, TAMIL NADU.

G. Sankar

Signature

Date: 28.7.17

**K S R INSTITUTE FOR ENGINEERING AND TECHNOLOGY  
TIRUCHENGODE - 637 215**

**TRAINING PROGRAMME FEEDBACK FORM**



Name of the Student: S. KARTHICEYAN

Branch: Mechanical

Year / Sem: VI / 07

1. Name of the Training: Appitudo

2. Name of the Trainer: sharmila

3. Students rating of Trainers :

S. No.	Date	Subject	Rating (✓)			
			Excellent	Very good	Good	Average
1	28-07-17	Geometry measurement		✓		

4. Two positive points about the programme:

\* Easily understood \* give easily shortcuts,

5. Suggestions for improvement:

\* to give more important <sup>problem</sup> concepts

Date:

28-07-17

Signature

S. Karthikeyan

**K S R INSTITUTE FOR ENGINEERING AND TECHNOLOGY  
TIRUCHENGODE - 637 215**

**TRAINING PROGRAMME FEEDBACK FORM**



Name of the Student: M. BARATHARAJ

Branch: Mechanical

Year / Sem: IV / VII

4. Name of the Training: Appitudo

5. Name of the Trainer: sharmila

6. Students rating of Trainers :

S. No.	Date	Subject	Rating (✓)			
			Excellent	Very good	Good	Average
1	28/07/17	Geometry & construction		✓		

4. Two positive points about the programme:

Easily reachable and easy understandable.

5. Suggestions for improvement:

If the training classes held in morning it will be helpful

Date:

28/07/17

Signature

M. Baratharaj

K S R INSTITUTE FOR ENGINEERING AND TECHNOLOGY  
TIRUCHENGODE - 637 215

TRAINING PROGRAMME FEEDBACK FORM



Name of the Student: Draveer kumar . B

Branch: IV-EEE

Year / Sem: IV / 7<sup>th</sup> Sem.

1.Name of the Training : Algebra

2.Name of the Trainer : Sharmila

3.Students rating of Trainers : 4.5 / 5

S. No.	Date	Subject	Rating (✓)			
			Excellent	Very good	Good	Average
1	29/7/17		✓			

4. Two positive points about the programme:

- 1) New formula.
- 2) Easy short-cut to solve

5. Suggestions for improvement:

Date: 29.07.2017

B. D. ...  
Signature

K S R INSTITUTE FOR ENGINEERING AND TECHNOLOGY  
TIRUCHENGODE - 637 215

TRAINING PROGRAMME FEEDBACK FORM



Name of the Student: RADHAKRISHNAN - S

Branch: MECHANICAL

Year / Sem: IV / VII

1.Name of the Training : Selecting word, Algebra, Spotting Error.

2.Name of the Trainer : Sharmila

3.Students rating of Trainers : 10

S. No.	Date	Subject	Rating (✓)			
			Excellent	Very good	Good	Average
1	7/29/17	Algebra	✓			

4. Two positive points about the programme: \* Getting a o Many Short Cuts.  
\* Teaching Method is very Good.

5. Suggestions for improvement: Explain PRINCIPAL a Important Question. By

Date: 29/7/17

K. S. R. INSTITUTE FOR  
ENGINEERING AND TECHNOLOGY,  
K. S. R. KALVI NAGAR,  
TIRUCHENGODE - 637 215,  
NAMAKKAL Dt., TAMIL NADU.

Signature S. Prath...



Name of the Student: M. Ranjith Kumar

Branch: IV - Mech - B'

Year / Sem: IV / 87<sup>th</sup>

4. Name of the Training: Quants & Reasoning.

5. Name of the Trainer: Sharmila

6. Students rating of Trainers: 4.7/5

S. No.	Date	Subject	Rating (✓)			
			Excellent	Very good	Good	Average
1	29/7/17		✓			

4. Two positive points about the programme:

Shortcuts, new formulas.

5. Suggestions for improvement:

Date: 29. 7. 2017.

Signature

PRINCIPAL,  
K. S. R. INSTITUTE FOR  
ENGINEERING AND TECHNOLOGY,  
K. S. R. KALVI NAGAR,  
TIRUCHENGODE - 637 215,  
NAINAKKAL Dt, TAMIL NADU.

**K S R INSTITUTE FOR ENGINEERING AND TECHNOLOGY  
TIRUCHENGODE - 637 215**

**TRAINING PROGRAMME FEEDBACK FORM**



Name of the Student: T. Aniya

Branch: ECE

Year / Sem: IV/07

1.Name of the Training : Krishna

2.Name of the Trainer : Sinduja

3.Students rating of Trainers :

S. No.	Date	Subject	Rating (√)			
			Excellent	Very good	Good	Average
1	29.7.2017	sentence completion		✓		
	29.7.2017	Algebra		✓		

4. Two positive points about the programme:

a) clear in content

5. Suggestions for improvement:

Date: 29/7/17

T. Aniya  
Signature

**K S R INSTITUTE FOR ENGINEERING AND TECHNOLOGY  
TIRUCHENGODE - 637 215**

**TRAINING PROGRAMME FEEDBACK FORM**



Name of the Student: R. Nandhini

Branch: ECE

Year / Sem: IV/07

4.Name of the Training : Krishna

5.Name of the Trainer : Sinduja

6.Students rating of Trainers :

S. No.	Date	Subject	Rating (√)			
			Excellent	Very good	Good	Average
1	29.7.2017	sentence error		✓		
	29.7.2017	Algebra		✓		

4. Two positive points about the programme:

Explanation is clear.

5. Suggestions for improvement:

Date: 29/7/17

  
**PRINCIPAL,**  
**K S R INSTITUTE FOR**  
**ENGINEERING AND TECHNOLOGY,**  
**K. S. R. KALVI NAGAR,**  
**TIRUCHENGODE - 637 215,**  
**NAMAKKAL DI, TAMIL NADU.**

R. Nandhini  
Signature

K S R INSTITUTE FOR ENGINEERING AND TECHNOLOGY  
TIRUCHENGODE - 637 215



TRAINING PROGRAMME FEEDBACK FORM

Name of the Student: Elizabeth NJ

Branch: ECE

Year / Sem: IV / 7

1. Name of the Training: Gomathi

2. Name of the Trainer:

3. Students rating of Trainers:

S. No.	Date	Subject	Rating (√)			
			Excellent	Very good	Good	Average
1	29/7/17	Data Sufficiency			✓	

4. Two positive points about the programme:

Questions for test was from the portions covered

5. Suggestions for improvement:

Many questions of the was repeated and even answers was wrong.

Date: some 29/7/2017

Signature Elizabeth

K S R INSTITUTE FOR ENGINEERING AND TECHNOLOGY  
TIRUCHENGODE - 637 215



TRAINING PROGRAMME FEEDBACK FORM

Name of the Student: S. SUGUMAR

Branch: ECE

Year / Sem:

4. Name of the Training: QUANTZ

5. Name of the Trainer: GOMATHI

6. Students rating of Trainers:

S. No.	Date	Subject	Rating (√)			
			Excellent	Very good	Good	Average
1	29/7/17	Reasoning		✓		

(SEAT ARRANGEMENTS)

4. Two positive points about the programme:

Different kinds of questions.

5. Suggestions for improvement:

nil. ✓

Date:

29/7/17

PRINCIPAL,  
K. S. R. INSTITUTE FOR  
ENGINEERING AND TECHNOLOGY,  
K. S. R. KALVINAGAR,  
TIRUCHENGODE - 637 215,  
NAYAKKAL GI, TAMIL NADU.

Signature

K S R INSTITUTE FOR ENGINEERING AND TECHNOLOGY  
TIRUCHENGODE - 637 215

FN - Batch - 1

TRAINING PROGRAMME FEEDBACK FORM



Name of the Student: S.V. DINESH

Branch: MECHANICAL

Year / Sem: IV yr / 7<sup>th</sup> Sem

1. Name of the Training: Verbal, Quantitative

2. Name of the Trainer: Krishna, Sharmila

3. Students rating of Trainers :

S. No.	Date	Subject	Rating (√)			
			Excellent	Very good	Good	Average
1	29/7/17	Spotting errors, Algebra.		✓		

4. Two positive points about the programme:

They telling some new techniques for solving problem.

5. Suggestions for improvement:

They teaching very slowly.

Date: 29/7/17

S.V. DINESH  
Signature

K S R INSTITUTE FOR ENGINEERING AND TECHNOLOGY  
TIRUCHENGODE - 637 215

FN - Batch - 1

TRAINING PROGRAMME FEEDBACK FORM



Name of the Student: G. Mithun Chakravarthy

Branch: Mechanical

Year / Sem: IV yr / 7<sup>th</sup> Sem

4. Name of the Training: Verbal, Quantitative

5. Name of the Trainer: Krishna Sharmila Sridhar.

6. Students rating of Trainers :

S. No.	Date	Subject	Rating (√)			
			Excellent	Very good	Good	Average
1	29/7/17	Spotting errors, Algebra		✓		

4. Two positive points about the programme:

Teaching us a shortcut steps to solve the difficult problems

5. Suggestions for improvement:

Changing their way of communication.

Date: 29/7/17

K S R INSTITUTE FOR  
ENGINEERING AND TECHNOLOGY  
K. S. R. KALVI NAGAR,  
TIRUCHENGODE - 637 215,  
NAMAKKAL DISTRICT, TAMIL NADU.

[Signature]  
Signature

K S R INSTITUTE FOR ENGINEERING AND TECHNOLOGY  
TIRUCHENGODE - 637 215

TRAINING PROGRAMME FEEDBACK FORM



Name of the Student: A. N. DORNTHAR

Branch: EEE

Year / Sem: IV

1. Name of the Training: Aptitude - Reasoning

2. Name of the Trainer: Gomathi

3. Students rating of Trainers :

S. No.	Date	Subject	Rating (✓)			
			Excellent	Very good	Good	Average
1	29-7-17	Reasoning			✓	

4. Two positive points about the programme:

Helpful to attend many problems.  
Topics. Tests based on the known topics.

5. Suggestions for improvement:

✶

Date: 29-7-17

A. N. Dornthar  
Signature

K S R INSTITUTE FOR ENGINEERING AND TECHNOLOGY  
TIRUCHENGODE - 637 215

TRAINING PROGRAMME FEEDBACK FORM



Name of the Student: Karthik S. M.

Branch: EEE

Year / Sem: IV

4. Name of the Training: Aptitude Reasoning

5. Name of the Trainer: Gomathi

6. Students rating of Trainers :

S. No.	Date	Subject	Rating (✓)			
			Excellent	Very good	Good	Average
1	29.7.17	Reasoning				✓

4. Two positive points about the programme:

Some topics learned shortcuts

5. Suggestions for improvement:

Date: 29.7.17

PRINCIPAL,  
K. S. R. INSTITUTE FOR  
ENGINEERING AND TECHNOLOGY,  
K. S. R. KALVI NAGAR,  
TIRUCHENGODE - 637 215,  
NAMAKKAL Dt, TAMIL NADU.

T. M. Dornthar  
Signature



K S R INSTITUTE FOR ENGINEERING AND TECHNOLOGY  
TIRUCHENGODE - 637 215

TRAINING PROGRAMME FEEDBACK FORM



Name of the Student: Mephy Mony

Branch: B.Tech-IT

Year / Sem: IV / VII

1. Name of the Training: Reasoning

2. Name of the Trainer: Gomathi

3. Students rating of Trainers :

S. No.	Date	Subject	Rating (✓)			
			Excellent	Very good	Good	Average
1	29.7.17	Reasoning		✓		

4. Two positive points about the programme:

Going good with the respective training.

5. Suggestions for improvement:

No suggestions

Date: 29.7.17

Mephy  
Signature

K S R INSTITUTE FOR ENGINEERING AND TECHNOLOGY  
TIRUCHENGODE - 637 215

TRAINING PROGRAMME FEEDBACK FORM



Name of the Student: RM.Chindhamani

Branch: BE-CSE  
~~B.Tech~~

Year / Sem: IV / VII

4. Name of the Training: Quantitube

5. Name of the Trainer: Gomathi

6. Students rating of Trainers :

S. No.	Date	Subject	Rating (✓)			
			Excellent	Very good	Good	Average
1	29.7.17	Quantitube		✓		

4. Two positive points about the programme:

TO attend many problems  
Easy to understand

5. Suggestions for improvement:

NO suggestion

Date:

PRINCIPAL,  
K S R INSTITUTE FOR  
ENGINEERING AND TECHNOLOGY,  
K. S. R. KALVI NAGAR,  
TIRUCHENGODE - 637 215,  
NAMAKKAL DISTRICT, TAMIL NADU.

R.M. Ch  
Signature

**K S R INSTITUTE FOR ENGINEERING AND TECHNOLOGY**

**TIRUCHENGODE-637215**

**TRAINING AND PLACEMENT CELL**

**Training Programme [2017 – 2018] Odd Semester**



**Ref: KSRIET/T&P/CIR/2017-18**

**Date: 15.06.2017**

This is to inform all the HoDs and Faculty members that the 3 days Internal Training on Aptitude & Basic Grammar and Soft Skills for II year students during the academic year 2017 – 2018 (Odd Semester) has been scheduled. In this regard all the Department Placement Coordinators kindly share the details to the students for smooth conduction of Training Programmes. If any student skips the Training Programme without proper permission from the respective HoDs, he / she will not be permitted for any future Training Programme and campus recruitment process. Proper Dress Code is mandatory.

**Encl.**

Training venue and batch wise topics details.

  
**T&P OFFICER**

  
**T&P COORDINATOR**

  
**PRINCIPAL**

**Copy to:**

1. All HoDs
2. Notice Board

**Session Timings:**

**Forenoon Session: 09:00am – 12:30 pm**

**Break: 10.45 am to 11.00 am**

**Afternoon Session: 01:30pm – 04:00 pm**

**Lunch: 12.30 pm to 01.30 pm**

  
**PRINCIPAL,  
K. S. R. INSTITUTE FOR  
ENGINEERING AND TECHNOLOGY,  
K. S. R. KALVI NAGAR,  
TIRUCHENGODE - 637 215,  
TAMIL NADU.**

Training and Placement Cell -CSE  
Aptitude & Basic Grammar and Soft Skills Hall Arrangement

BATCH : 2016 - 2020

Year / Sem: II / III

S. No	Name	Branch	Batch No	Hall No	19.06.17				20.06.17				21.06.17				22.06.17				23.06.17				24.06.17													
					FN	AN	AN	AN	FN	AN	AN	AN	FN	AN	AN	AN	FN	AN	AN	AN	FN	AN	AN	AN	FN	AN	AN	AN										
1	VASU MITHA R S	CSE	I	409	/	/	/	/	/	/	/	/	/	/	/	/	/	/	/	/	/	/	/	/	/	/	/	/	/	/	/	/	/	/	/	/		
2	VELU PRABHA S	CSE	I	409	/	/	/	/	/	/	/	/	/	/	/	/	/	/	/	/	/	/	/	/	/	/	/	/	/	/	/	/	/	/	/			
3	STELIN BERCIA S	CSE	I	409	/	/	/	/	/	/	/	/	/	/	/	/	/	/	/	/	/	/	/	/	/	/	/	/	/	/	/	/	/	/	/			
4	SWETHA B	CSE	I	409	/	/	/	/	/	/	/	/	/	/	/	/	/	/	/	/	/	/	/	/	/	/	/	/	/	/	/	/	/	/	/			
5	DEVI GAYATHRI S	CSE	I	409	/	/	/	/	/	/	/	/	/	/	/	/	/	/	/	/	/	/	/	/	/	/	/	/	/	/	/	/	/	/	/			
6	SWETHA C	CSE	II	403	/	/	/	/	/	/	/	/	/	/	/	/	/	/	/	/	/	/	/	/	/	/	/	/	/	/	/	/	/	/	/			
7	RAJA RAJAN A	CSE	II	403	/	/	/	/	/	/	/	/	/	/	/	/	/	/	/	/	/	/	/	/	/	/	/	/	/	/	/	/	/	/	/			
8	JEEVITHA R	CSE	II	403	/	/	/	/	/	/	/	/	/	/	/	/	/	/	/	/	/	/	/	/	/	/	/	/	/	/	/	/	/	/	/			
9	SHILPA B	CSE	II	403	/	/	/	/	/	/	/	/	/	/	/	/	/	/	/	/	/	/	/	/	/	/	/	/	/	/	/	/	/	/	/			
10	SOUNDHARYA A	CSE	II	403	/	/	/	/	/	/	/	/	/	/	/	/	/	/	/	/	/	/	/	/	/	/	/	/	/	/	/	/	/	/	/			
11	INDIRA PRIYADHARSHINI P	CSE	II	403	/	/	/	/	/	/	/	/	/	/	/	/	/	/	/	/	/	/	/	/	/	/	/	/	/	/	/	/	/	/	/			
12	MANJULA R	CSE	III	413	/	/	/	/	/	/	/	/	/	/	/	/	/	/	/	/	/	/	/	/	/	/	/	/	/	/	/	/	/	/	/			
13	YUVAPRIYANKA V	CSE	III	413	/	/	/	/	/	/	/	/	/	/	/	/	/	/	/	/	/	/	/	/	/	/	/	/	/	/	/	/	/	/	/			
14	MANIKANDAN K	CSE	III	413	/	/	/	/	/	/	/	/	/	/	/	/	/	/	/	/	/	/	/	/	/	/	/	/	/	/	/	/	/	/	/			
15	PUGAZHIVELAN P	CSE	III	413	/	/	/	/	/	/	/	/	/	/	/	/	/	/	/	/	/	/	/	/	/	/	/	/	/	/	/	/	/	/	/			
16	PRAVEEN KUMAR M	CSE	IV	404	/	/	/	/	/	/	/	/	/	/	/	/	/	/	/	/	/	/	/	/	/	/	/	/	/	/	/	/	/	/	/	/		
17	AJITH KUMAR P	CSE	IV	404	/	/	/	/	/	/	/	/	/	/	/	/	/	/	/	/	/	/	/	/	/	/	/	/	/	/	/	/	/	/	/	/		
18	MEGASURIYAN E	CSE	IV	404	/	/	/	/	/	/	/	/	/	/	/	/	/	/	/	/	/	/	/	/	/	/	/	/	/	/	/	/	/	/	/	/		
19	DHRANI K	CSE	V	408	/	/	/	/	/	/	/	/	/	/	/	/	/	/	/	/	/	/	/	/	/	/	/	/	/	/	/	/	/	/	/	/		
20	HARINI R	CSE	V	408	/	/	/	/	/	/	/	/	/	/	/	/	/	/	/	/	/	/	/	/	/	/	/	/	/	/	/	/	/	/	/	/		
21	ILAKIYA S	CSE	V	408	/	/	/	/	/	/	/	/	/	/	/	/	/	/	/	/	/	/	/	/	/	/	/	/	/	/	/	/	/	/	/	/		
22	SELVAMALINI J	CSE	V	408	/	/	/	/	/	/	/	/	/	/	/	/	/	/	/	/	/	/	/	/	/	/	/	/	/	/	/	/	/	/	/	/		
23	SRUTHI S	CSE	VI	405	/	/	/	/	/	/	/	/	/	/	/	/	/	/	/	/	/	/	/	/	/	/	/	/	/	/	/	/	/	/	/	/		
24	DEVADHARSHINI SS	CSE	VI	405	/	/	/	/	/	/	/	/	/	/	/	/	/	/	/	/	/	/	/	/	/	/	/	/	/	/	/	/	/	/	/	/		
25	VENMATHI S	CSE	VI	405	/	/	/	/	/	/	/	/	/	/	/	/	/	/	/	/	/	/	/	/	/	/	/	/	/	/	/	/	/	/	/	/		
26	GOWRI S	CSE	VI	405	/	/	/	/	/	/	/	/	/	/	/	/	/	/	/	/	/	/	/	/	/	/	/	/	/	/	/	/	/	/	/	/		
27	INDHU R	CSE	VI	405	/	/	/	/	/	/	/	/	/	/	/	/	/	/	/	/	/	/	/	/	/	/	/	/	/	/	/	/	/	/	/	/		
28	NATHISH KUMAR A	CSE	VI	405	/	/	/	/	/	/	/	/	/	/	/	/	/	/	/	/	/	/	/	/	/	/	/	/	/	/	/	/	/	/	/	/		
29	ARUN R	CSE	VI	405	/	/	/	/	/	/	/	/	/	/	/	/	/	/	/	/	/	/	/	/	/	/	/	/	/	/	/	/	/	/	/	/		
30	SUBHASREE S	CSE	VI	405	/	/	/	/	/	/	/	/	/	/	/	/	/	/	/	/	/	/	/	/	/	/	/	/	/	/	/	/	/	/	/	/		
31	ANISHA N	CSE	VI	405	/	/	/	/	/	/	/	/	/	/	/	/	/	/	/	/	/	/	/	/	/	/	/	/	/	/	/	/	/	/	/	/		
32	VENKATESH M	CSE	VII	312	/	/	/	/	/	/	/	/	/	/	/	/	/	/	/	/	/	/	/	/	/	/	/	/	/	/	/	/	/	/	/	/		
33	MOHAMMEDSAMIR A	CSE	VII	312	/	/	/	/	/	/	/	/	/	/	/	/	/	/	/	/	/	/	/	/	/	/	/	/	/	/	/	/	/	/	/	/		
34	LAXMANCIBI S	CSE	VII	312	/	/	/	/	/	/	/	/	/	/	/	/	/	/	/	/	/	/	/	/	/	/	/	/	/	/	/	/	/	/	/	/	/	
35	JAYAVARSHINI G	CSE	VII	312	/	/	/	/	/	/	/	/	/	/	/	/	/	/	/	/	/	/	/	/	/	/	/	/	/	/	/	/	/	/	/	/	/	
36	PAVITHIRAN S	CSE	VII	312	/	/	/	/	/	/	/	/	/	/	/	/	/	/	/	/	/	/	/	/	/	/	/	/	/	/	/	/	/	/	/	/	/	
37	VISVESWARAN B	CSE	VII	312	/	/	/	/	/	/	/	/	/	/	/	/	/	/	/	/	/	/	/	/	/	/	/	/	/	/	/	/	/	/	/	/	/	
38	VIGNESH G	CSE	VII	312	/	/	/	/	/	/	/	/	/	/	/	/	/	/	/	/	/	/	/	/	/	/	/	/	/	/	/	/	/	/	/	/	/	
39	PRIYANKA V	CSE	VII	312	/	/	/	/	/	/	/	/	/	/	/	/	/	/	/	/	/	/	/	/	/	/	/	/	/	/	/	/	/	/	/	/	/	
40	BARATH K	CSE	VII	312	/	/	/	/	/	/	/	/	/	/	/	/	/	/	/	/	/	/	/	/	/	/	/	/	/	/	/	/	/	/	/	/	/	
41	KAMALESH M	CSE	VIII	305	/	/	/	/	/	/	/	/	/	/	/	/	/	/	/	/	/	/	/	/	/	/	/	/	/	/	/	/	/	/	/	/	/	
42	NIVETHITHA N	CSE	VIII	305	/	/	/	/	/	/	/	/	/	/	/	/	/	/	/	/	/	/	/	/	/	/	/	/	/	/	/	/	/	/	/	/	/	
43	GOWTHAM KUMARAN P	CSE	VIII	305	/	/	/	/	/	/	/	/	/	/	/	/	/	/	/	/	/	/	/	/	/	/	/	/	/	/	/	/	/	/	/	/	/	
44	AKILAN Y	CSE	VIII	305	/	/	/	/	/	/	/	/	/	/	/	/	/	/	/	/	/	/	/	/	/	/	/	/	/	/	/	/	/	/	/	/	/	
45	PREMNATH R	CSE	VIII	305	/	/	/	/	/	/	/	/	/	/	/	/	/	/	/	/	/	/	/	/	/	/	/	/	/	/	/	/	/	/	/	/	/	
46	DEEPAK SURIYA A	CSE	VIII	305	/	/	/	/	/	/	/	/	/	/	/	/	/	/	/	/	/	/	/	/	/	/	/	/	/	/	/	/	/	/	/	/	/	
47	PUJAA V	CSE	VIII	305	/	/	/	/	/	/	/	/	/	/	/	/	/	/	/	/	/	/	/	/	/	/	/	/	/	/	/	/	/	/	/	/	/	
48																																						
49																																						
		PRESENT																																				
		ABSENT																																				
		PERMISSION																																				

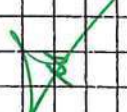
  
**PRINCIPAL,**  
 K. S. R. INSTITUTE FOR  
 ENGINEERING AND TECHNOLOGY,  
 K. S. R. KALVI NAGAR,  
 TIRUCHENGODE - 637 215,  
 NAMANKAL Dt, TAMIL NADU.





**Training and Placement Cell - ECE B**  
**Aptitude & Basic Grammar and Soft Skills Hall Arrangement**

**BATCH : 2016 - 2020**

**Year / Sem: II / III**

S. No	Name	Branch	Batch No	Hall No	19.06.17				20.06.17				21.06.17				22.06.17				23.06.17				24.06.17			
					FN	FN	AN	AN	FN	FN	AN	AN	FN	FN	AN	AN	FN	FN	AN	AN	FN	FN	AN	AN	FN	FN	AN	AN
1	NIVETHA S	ECE B	I	409	/	/	/	/	a	/	/	/	/	/	/	/	/	/	/	/	/	/	/	/				
2	ROSHINI T	ECE B	I	409	/	/	/	/	/	/	/	/	/	/	/	/	/	/	/	/	/	/	/	/				
3	TAMILARASI S	ECE B	I	409	/	/	/	/	/	/	/	/	/	/	/	/	/	/	/	/	/	/	/	/				
4	PRIYANKA S S	ECE B	I	409	/	/	/	/	/	/	/	/	a	a	a	/	/	/	/	/	/	/	/	/				
5	SELLAKRISHNARAJA S	ECE B	I	409	/	/	/	/	/	/	/	/	/	/	/	/	/	/	/	/	/	/	/	/				
6	YOGESH S	ECE B	I	409	/	/	/	/	/	/	/	/	/	/	/	/	/	/	/	/	/	/	/	/				
7	PRIYADHARSHNI P	ECE B	II	403	/	/	/	/	/	/	/	/	/	/	/	/	/	/	a	a	a	/	/	/				
8	NARESHKUMAR S	ECE B	II	403	/	/	/	/	/	/	/	/	/	/	/	/	/	/	/	/	a	a	a	/				
9	NIVETHA T	ECE B	II	403	/	/	/	/	/	/	/	/	/	/	/	/	/	/	/	/	/	/	/	/				
10	SRIMATHI G	ECE B	II	403	/	/	/	/	/	/	/	/	a	a	a	/	/	/	/	/	/	/	/	/				
11	NANDHAKUMAR P	ECE B	III	413	a	a	a	a	/	/	/	/	/	/	/	/	/	/	/	/	/	/	/	/				
12	THAMARAIAKANNAN AS	ECE B	III	413	/	/	/	/	/	/	/	/	/	/	/	/	/	/	/	/	/	/	/	/				
13	POORNIMA N	ECE B	III	413	/	/	/	a	a	a	/	/	/	/	/	/	/	/	/	/	/	/	/	/				
14	RAMYA SRI E	ECE B	IV	404	/	/	/	/	/	/	/	/	/	/	/	/	/	e	a	a	a	/	/	/				
15	SYED SALMAN N	ECE B	IV	404	/	/	/	/	/	/	/	/	/	/	/	/	/	/	/	/	/	/	/	/				
16	SUMATHI R	ECE B	V	408	/	/	/	/	/	/	a	a	a	/	/	/	/	/	/	/	/	/	/	/				
17	PRIYADHARSHINI M	ECE B	V	408	/	/	/	/	/	/	/	/	/	/	/	/	/	/	/	/	/	a	a	a				
18	SATHYAMOORTHY K	ECE B	V	408	/	/	/	/	/	/	/	/	/	/	/	/	/	/	/	/	/	/	/	/				
19	NAVEEN K	ECE B	V	408	/	/	/	/	/	/	/	/	/	/	/	/	/	/	/	/	/	/	/	/				
20	PRAVEENA M	ECE B	V	408	/	/	/	/	/	/	/	/	a	a	a	/	/	/	/	/	/	/	/	/				
21	THARANYA P	ECE B	V	408	/	/	/	/	/	/	/	/	/	/	/	/	/	/	/	/	/	/	/	/				
22	VIMAL KUMAR R	ECE B	V	408	/	/	/	/	/	/	/	/	/	/	/	/	/	a	a	/	/	/	/	/				
23	SANTHIA G	ECE B	V	408	a	a	a	/	/	/	/	/	/	/	/	/	/	/	/	/	/	/	/	/				
24	NANDHAKUMARAN R	ECE B	V	408	/	/	/	/	/	/	/	/	/	/	/	/	/	/	/	/	/	/	/	/				
25	SANTHOSHKUMAR J	ECE B	V	408	/	/	/	a	/	/	/	/	/	/	/	/	/	/	/	/	/	/	/	/				
26	THANGAVEL P	ECE B	VI	405	/	/	/	/	/	/	/	/	/	/	/	/	/	/	/	/	/	/	/	/				
27	PRIYADHARSHINI S	ECE B	VI	405	/	/	/	/	/	/	a	/	/	/	/	/	/	/	/	/	/	/	/	/				
28	SHARVESHRAM K R	ECE B	VI	405	/	/	/	/	/	/	/	/	/	/	/	/	/	/	/	/	/	/	/	/				
29	SHOWMIYA M	ECE B	VI	405	a	a	a	/	/	/	/	/	/	/	/	/	/	/	/	/	/	/	/	/				
30	SAKTHI PRIYA S	ECE B	VI	405	/	/	/	/	/	/	/	/	/	/	/	/	/	/	/	/	/	/	/	/				
31	THANGARAJ J	ECE B	VI	405	/	/	/	/	/	/	/	a	/	/	/	/	/	/	/	/	/	/	/	/				
32	VIGNESH R	ECE B	VII	312	/	/	/	/	/	/	/	/	/	/	/	/	/	/	/	/	/	/	/	/				
33	PRIYANKA C	ECE B	VII	312	/	/	/	a	/	/	/	/	/	/	/	/	/	/	/	/	/	/	/	/				
34	NANDHAKUMAR M	ECE B	VII	312	/	/	/	/	/	/	/	/	/	/	/	/	/	/	/	/	/	/	/	/				
35	SHYAM SUNDAR R	ECE B	VII	312	/	/	/	/	/	/	a	/	/	/	/	/	/	/	/	/	/	/	/	/				
36	SUBASH V	ECE B	VIII	305	a	a	a	/	/	/	/	/	/	/	/	/	/	/	/	/	/	/	/	/				
37	SURIYA E	ECE B	VIII	305	/	/	/	/	/	/	/	/	/	/	/	/	/	/	/	/	/	/	/	/				
38	SUBASHINI R	ECE B	VIII	305	/	/	/	/	/	/	/	/	/	/	/	/	/	/	/	/	/	a	a	a				
39	MUGILAN M	ECE B	VIII	305	/	/	/	/	/	/	/	/	/	/	/	/	/	/	/	/	/	/	/	/				
40	SURYA R	ECE B	VIII	305	/	/	/	/	/	/	/	/	/	/	/	/	/	/	/	/	/	/	/	/				
41	RANJITH V	ECE B	VIII	305	/	/	/	/	/	/	/	/	/	/	/	/	/	/	/	/	/	/	/	/				
42	VIGNESH P	ECE B	VIII	305	/	/	/	/	/	/	/	/	/	/	/	/	/	/	/	/	/	a	a	a				
43																												
44																												
45																												
				<b>PRESENT</b>																								
				<b>ABSENT</b>																								
				<b>PERMISSION</b>																								

PRINCIPAL,  
 K. S. R. INSTITUTE FOR  
 ENGINEERING AND TECHNOLOGY,  
 K. S. R. KALVI NAGAR,  
 TIRUCHENGODE - 637 215,  
 NARAYANAL Dt, TAMIL NADU.

Training and Placement Cell - EEE

Aptitude & Basic Grammar and Soft Skills Hall Arrangement

BATCH : 2016 - 2020

Year / Sem: II / III

S. No	Name	Branch	Batch No	Hall No	19.06.17				20.06.17				21.06.17				22.06.17				23.06.17				24.06.17					
					FN	FN	AN	AN	FN	FN	AN	AN	FN	FN	AN	AN	FN	FN	AN	AN	FN	FN	AN	AN	FN	FN	AN	AN	FN	FN
1	SARANYA.P	EEE	I	409	/	/	/	/	/	/	/	/	/	/	/	/	/	/	/	/	/	/	/	/	/	/	/	/		
2	MYTHILIN	EEE	I	409	/	/	/	/	/	/	/	/	/	/	/	/	/	/	/	/	/	/	/	/	/	/	/	/		
3	MADHUMITHA.J.S	EEE	I	409	/	/	/	/	/	/	/	/	/	/	/	/	/	/	/	/	/	/	/	/	/	/	/	/		
4	NITHIYASRI.R	EEE	I	409	/	/	/	/	/	/	/	/	/	/	/	/	/	/	/	/	/	/	/	/	/	/	/	/		
5	VIVEK.V	EEE	I	409	a	a	a	a	/	/	/	/	/	/	/	/	/	/	/	/	/	/	/	/	/	/	/	/		
6	NANDHINI.M	EEE	II	403	/	/	/	/	/	/	/	/	/	/	/	/	/	/	/	/	/	/	/	/	/	/	/	/		
7	SHANKAR NARAYAN.M	EEE	II	403	/	/	/	/	/	/	/	/	/	/	/	/	/	/	/	/	/	/	/	/	/	/	/	/		
8	KAMALI SOUNDARYA.B	EEE	II	403	/	/	/	/	/	/	/	/	/	/	/	/	/	/	/	/	/	/	/	/	/	/	/	/		
9	PREETHA.E	EEE	II	403	/	/	/	/	/	/	/	/	/	/	/	/	/	/	/	/	/	/	/	/	/	/	/	/		
10	LATHA.S	EEE	II	403	a	a	a	a	/	/	/	/	/	/	/	/	/	/	/	/	/	/	/	/	/	/	/	/		
11	JANANI.T	EEE	II	403	/	/	/	/	/	/	/	/	/	/	/	/	/	/	/	/	/	/	/	/	/	/	/	/		
12	MONISHA.S	EEE	II	403	/	/	/	/	/	/	/	/	/	/	/	/	/	/	/	/	/	/	/	/	/	/	/	/		
13	BHARATHI KANNAN.M.R	EEE	II	403	/	/	/	/	/	/	/	/	/	/	/	/	/	/	/	/	/	/	/	/	/	/	/	/		
14	SUVETHA.T	EEE	II	403	a	a	a	a	/	/	/	/	/	/	/	/	/	/	/	/	/	/	/	/	/	/	/	/		
15	MUGESH.M	EEE	III	413	/	/	/	/	/	/	/	/	/	/	/	/	/	/	/	/	/	/	/	/	/	/	/	/		
16	PREMKUMAR.G	EEE	III	413	/	/	/	/	/	/	/	/	/	/	/	/	/	/	/	/	/	/	/	/	/	/	/	/		
17	PIREETHI.A	EEE	III	413	/	/	/	/	/	/	/	/	/	/	/	/	/	/	/	/	/	/	/	/	/	/	/	/		
18	NANCY ASMITHA.P.A	EEE	III	413	/	/	/	/	/	/	/	/	/	/	/	/	/	/	/	/	/	/	/	/	/	/	/	/		
19	MANOJKUMAR.V	EEE	III	413	/	/	/	/	/	/	/	/	/	/	/	/	/	/	/	/	/	/	/	/	/	/	/	/		
20	AJITHA.P	EEE	III	413	/	/	/	/	/	/	/	/	/	/	/	/	/	/	/	/	/	/	/	/	/	/	/	/		
21	LOGESHWARAN.V	EEE	III	413	/	/	/	/	/	/	/	/	/	/	/	/	/	/	/	/	/	/	/	/	/	/	/	/		
22	KARTHIKA DEVI.S	EEE	IV	404	/	/	/	/	/	/	/	/	/	/	/	/	/	/	/	/	/	/	/	/	/	/	/	/		
23	SARAVANAN.V	EEE	IV	404	a	a	a	a	/	/	/	/	/	/	/	/	/	/	/	/	/	/	/	/	/	/	/	/		
24	BOOPATHI.M	EEE	IV	404	/	/	/	/	/	/	/	/	/	/	/	/	/	/	/	/	/	/	/	/	/	/	/	/		
25	BHARATH.S	EEE	IV	404	/	/	/	/	/	/	/	/	/	/	/	/	/	/	/	/	/	/	/	/	/	/	/	/		
26	DIVYADEV.V	EEE	IV	404	/	/	/	/	/	/	/	/	/	/	/	/	/	/	/	/	/	/	/	/	/	/	/	/		
27	SIBIN.S	EEE	IV	404	/	/	/	/	/	/	/	/	/	/	/	/	/	/	/	/	/	/	/	/	/	/	/	/		
28	SUJITHA.E	EEE	IV	404	a	a	a	a	/	/	/	/	/	/	/	/	/	/	/	/	/	/	/	/	/	/	/	/		
29	ANBALAGAN M	EEE	IV	404	/	/	/	/	/	/	/	/	/	/	/	/	/	/	/	/	/	/	/	/	/	/	/	/		
30	MERLIN INFANTA	EEE	V	408	/	/	/	/	/	/	/	/	/	/	/	/	/	/	/	/	/	/	/	/	/	/	/	/		
31	JEEVA.M	EEE	V	408	/	/	/	/	/	/	/	/	/	/	/	/	/	/	/	/	/	/	/	/	/	/	/	/		
32	PRAKASH.S.P	EEE	V	408	/	/	/	/	/	/	/	/	/	/	/	/	/	/	/	/	/	/	/	/	/	/	/	/		
33	KAVIYA.M	EEE	V	408	a	a	a	a	/	/	/	/	/	/	/	/	/	/	/	/	/	/	/	/	/	/	/	/		
34	INIYADHARINI.R	EEE	V	408	/	/	/	/	/	/	/	/	/	/	/	/	/	/	/	/	/	/	/	/	/	/	/	/		
35	KANIMOZHI.V	EEE	VI	405	/	/	/	/	/	/	/	/	/	/	/	/	/	/	/	/	/	/	/	/	/	/	/	/		
36	PRAVEEN.D	EEE	VI	405	/	/	/	/	/	/	/	/	/	/	/	/	/	/	/	/	/	/	/	/	/	/	/	/		
37	PRAVIN.R	EEE	VI	405	/	/	/	/	/	/	/	/	/	/	/	/	/	/	/	/	/	/	/	/	/	/	/	/		
38	JEEVA.R	EEE	VII	312	a	a	a	a	/	/	/	/	/	/	/	/	/	/	/	/	/	/	/	/	/	/	/	/		
39	ARAVIND.R	EEE	VII	312	/	/	/	/	/	/	/	/	/	/	/	/	/	/	/	/	/	/	/	/	/	/	/	/		
40	DHILIP KUMAR.S.K	EEE	VII	312	/	/	/	/	/	/	/	/	/	/	/	/	/	/	/	/	/	/	/	/	/	/	/	/		
41	MOHANRAJ.S	EEE	VII	312	/	/	/	/	/	/	/	/	/	/	/	/	/	/	/	/	/	/	/	/	/	/	/	/		
42	NAVANEETHAN.S	EEE	VII	312	/	/	/	/	/	/	/	/	/	/	/	/	/	/	/	/	/	/	/	/	/	/	/	/		
43	KAVINKUMAR.K	EEE	VII	312	/	/	/	/	/	/	/	/	/	/	/	/	/	/	/	/	/	/	/	/	/	/	/	/		
44	AKILAN.G	EEE	VIII	305	/	/	/	/	/	/	/	/	/	/	/	/	/	/	/	/	/	/	/	/	/	/	/	/		
45	GANESHBABU.V	EEE	VIII	305	/	/	/	/	/	/	/	/	/	/	/	/	/	/	/	/	/	/	/	/	/	/	/	/		
46	MADHUBALAN.S	EEE	VIII	305	/	/	/	/	/	/	/	/	/	/	/	/	/	/	/	/	/	/	/	/	/	/	/	/		
47	AJITH.K	EEE	VIII	305	/	/	/	/	/	/	/	/	/	/	/	/	/	/	/	/	/	/	/	/	/	/	/	/		
48																														
49																														
PRESENT																														
ABSENT																														
PERMISSION																														

  
**PRINCIPAL**  
**K. S. R. INSTITUTE FOR ENGINEERING AND TECHNOLOGY,**  
**K. S. R. KALVI NAGAR,**  
**TIRUCHENGODE - 637 215,**  
**NAMAKKAL DI, TAMIL NADU.**

BATCH : 2016 - 2020

Year / Sem: II / III

S. No	Name	Branch	Batch No	Hall No	19.06.17				20.06.17				21.06.17				22.06.17				23.06.17				24.06.17			
					FN	FN	AN	AN	FN	FN	AN	AN	FN	FN	AN	AN	FN	FN	AN	AN	FN	FN	AN	AN	FN	FN	AN	AN
1	ANNAMALAI K	MECH A	I	409	/	/	/	/	/	/	/	/	/	/	/	/	/	/	/	/	/	/	/	/	/			
2	INBARASAN C	MECH A	I	409	/	/	/	/	/	/	/	/	/	/	/	/	/	/	/	/	/	/	/	/	/			
3	DEEPAK R	MECH A	I	409	a	a	a	a	/	/	/	/	/	/	/	/	/	/	/	/	/	/	/	/	/			
4	GOKULRAJ P	MECH A	I	409	/	/	/	/	/	/	/	/	/	/	/	/	/	/	/	/	/	/	/	/	/			
5	JESTINRAJ K	MECH A	I	409	/	/	/	/	/	/	/	/	/	/	/	/	/	/	/	/	/	/	/	/	/			
6	GUNASEKARAN R	MECH A	II	403	/	/	/	/	/	/	/	/	/	/	/	/	/	/	/	/	/	/	/	/	/			
7	DINESH KUMAR C	MECH A	II	403	a	a	a	a	/	/	/	/	/	/	/	/	/	/	/	/	/	/	/	/	/			
8	MADHANKUMAR L	MECH A	II	403	/	/	/	/	/	/	/	/	a	a	/	/	/	/	/	/	/	/	/	/	/			
9	LAKSHMI NARAYANAN R	MECH A	II	403	/	/	/	/	/	/	/	/	/	/	/	/	/	/	/	/	/	/	/	/	/			
10	MOHANA KRISHNAN D	MECH A	II	403	/	/	/	/	/	/	/	/	/	/	/	/	/	/	/	/	/	/	/	/	/			
11	JAYAMURUGAN K S	MECH A	II	403	/	/	/	/	/	/	/	/	/	/	/	/	/	/	/	/	/	/	/	/	/			
12	LOGESH S	MECH A	II	403	a	a	a	a	/	/	/	/	/	/	/	/	/	/	/	/	/	/	/	/	/			
13	ASWINKUMAR S	MECH A	II	403	/	/	/	/	/	/	/	/	/	/	/	/	/	/	/	/	/	/	/	/	/			
14	HARI SHANKAR P	MECH A	II	403	/	/	/	/	/	/	/	/	/	/	/	/	/	/	/	/	/	/	/	/	/			
15	DHEVENDRAN E	MECH A	II	403	/	/	/	/	/	/	/	/	/	/	/	/	/	/	/	/	/	/	/	/	/			
16	LOGESH N	MECH A	II	403	/	/	/	/	/	/	/	/	/	/	/	/	/	/	/	/	/	/	/	/	/			
17	JOSHUA Y	MECH A	III	413	/	/	/	/	/	/	/	/	/	/	/	/	/	/	/	/	/	/	/	/	/			
18	KALEESWARAN D	MECH A	III	413	/	/	/	/	/	/	/	/	/	/	/	/	/	/	/	/	/	/	/	/	/			
19	HARIHARAN M	MECH A	III	413	/	/	/	/	a	a	a	a	/	/	/	/	/	/	/	/	/	/	/	/	/			
20	GOPINATH G	MECH A	III	413	/	/	/	/	/	/	/	/	/	/	/	/	/	/	/	/	/	/	/	/	/			
21	KEERTHIVASAN.S	MECH A	III	413	/	/	/	/	/	/	/	/	/	/	/	/	/	/	/	/	/	/	/	/	/			
22	KARTHIKEYAN P	MECH A	III	413	/	/	/	/	/	/	/	/	/	/	/	/	/	/	/	/	/	/	/	/	/			
23	GOVINDASAMY.A	MECH A	III	413	a	a	a	a	/	/	/	/	/	/	/	/	/	/	/	/	/	/	/	/	/			
24	HARIHARAN S	MECH A	III	413	/	/	/	/	/	/	/	/	/	a	a	a	a	/	/	/	/	/	/	/	/			
25	CHANDRASEKAR K	MECH A	III	413	/	/	/	/	/	/	/	/	/	/	/	/	/	/	/	/	/	/	/	/	/			
26	KEVIN SEBASTIN R	MECH A	IV	404	/	/	/	/	/	/	/	/	/	/	/	/	/	/	/	/	/	/	/	/	/			
27	KAROLE INFANTO D	MECH A	IV	404	/	/	/	/	a	a	a	a	/	/	/	/	/	/	/	/	/	/	/	/	/			
28	DHINAKARAN P	MECH A	IV	404	/	/	/	/	/	/	/	/	/	/	/	/	/	/	/	/	/	/	/	/	/			
29	BHARATH V	MECH A	IV	404	/	/	/	/	/	/	/	/	/	/	/	/	/	/	/	/	/	/	/	/	/			
30	JEEVA M	MECH A	IV	404	a	a	a	a	/	/	/	/	/	/	/	/	/	/	/	/	/	/	/	/	/			
31	KIRUBAKARAN M	MECH A	V	408	/	/	/	/	/	/	/	/	/	/	/	/	/	/	/	/	/	/	/	/	/			
32	CHELLATHURAI T	MECH A	V	408	/	/	/	/	/	/	/	/	/	a	a	a	a	/	/	/	/	/	/	/	/			
33	KESAV GOUTHAM N B	MECH A	V	408	/	/	/	/	/	/	/	/	/	/	/	/	/	/	/	/	/	/	/	/	/			
34	MANIKANDAN V	MECH A	V	408	/	/	/	/	/	/	/	/	/	/	/	/	/	/	/	/	/	/	/	/	/			
35	JEEVA K	MECH A	VI	405	/	/	/	/	/	/	/	/	/	/	/	/	/	/	/	/	/	/	/	/	/			
36	KAVIN P	MECH A	VI	405	a	a	a	a	a	a	a	a	/	/	/	/	/	/	/	/	/	/	/	/	/			
37	AAKASH S	MECH A	VI	405	/	/	/	/	/	/	/	/	/	/	/	/	/	/	/	/	/	/	/	/	/			
38	BOOPATHY K M	MECH A	VI	405	/	/	/	/	/	/	/	/	/	/	/	/	/	/	/	/	/	/	/	/	/			
39	KAVINKUMAR R	MECH A	VI	405	/	/	/	/	/	/	/	/	/	/	/	/	/	/	a	/	/	/	/	/	/			
40	MOHANRAJ B	MECH A	VI	405	/	/	/	/	/	/	/	/	/	/	/	/	/	/	/	/	/	/	/	/	/			
41	MAGESWARAN A	MECH A	VI	405	a	a	a	a	/	/	/	/	/	/	/	/	/	/	/	/	/	/	/	/	/			
42	BOOPATHIRAJA E	MECH A	VII	312	/	/	/	/	/	/	/	/	/	/	/	/	/	/	/	/	/	/	/	/	/			
43	GOWTHAM P	MECH A	VII	312	/	/	/	/	a	a	a	a	/	/	/	/	/	/	/	/	/	/	/	/	/			
44	ARSHATH S	MECH A	VII	312	/	/	/	/	/	/	/	/	/	/	/	/	/	/	/	/	/	/	/	/	/			
45	MOHAMMED NIHAL R	MECH A	VII	312	a	a	a	a	/	/	/	/	/	/	/	/	/	/	/	/	/	/	/	/	/			
46	GOKUL R	MECH A	VIII	305	/	/	/	/	/	/	/	/	/	/	/	/	/	/	/	/	/	/	/	/	/			
47	MANOJ KUMAR K	MECH A	VIII	305	/	/	/	/	/	/	/	/	/	/	/	/	/	/	/	/	/	/	/	/	/			
48	DHAYANIDHI M	MECH A	VIII	305	a	a	a	a	/	/	/	/	/	/	/	/	/	/	/	/	/	/	/	/	/			
49	AJITH M	MECH A	VIII	305	/	/	/	/	/	/	/	/	/	/	/	/	/	/	/	/	/	/	/	/	/			
50	MOHAN ARJUN KUMARAVEL	MECH A	VIII	305	/	/	/	/	/	/	/	/	/	/	/	/	/	/	/	/	/	/	/	/	/			
PRESENT																												
ABSENT																												
PERMISSION																												





Fore Noon session

S.NO	BRANCH	STRENGTH	No of Placement Not Registered Students	PRESENT	ABSENT	Leave
1	CSE	47	47	38	8	1
2	ECE - A	42	42	26	16	-
3	ECE - B	42	42	38	4	-
4	EEE	47	47	40	7	-
5	IT	45	45	37	8	-
6	MECH - A	50	50	41	9	-
7	MECH - B	49	49	46	3	-
<b>Total</b>		<b>322</b>	<b>322</b>	<b>266</b>	<b>55</b>	<b>1</b>

After Noon Session

S.NO	BRANCH	STRENGTH	No of Placement Not Registered Students	PRESENT	ABSENT	PERMISSION
1	CSE	47	47	37	9	1
2	ECE - A	42	42	26	16	-
3	ECE - B	42	42	38	4	-
4	EEE	47	47	40	7	-
5	IT	45	45	34	11	-
6	MECH - A	50	50	40	9	1
7	MECH - B	49	49	43	6	-
<b>Total</b>		<b>322</b>	<b>322</b>	<b>258</b>	<b>62</b>	<b>2</b>

*[Signature]*  
T & P OFFICER

*[Signature]*  
T & P COORDINATOR

*[Signature]*  
PRINCIPAL

PRINCIPAL,  
K. S. R. INSTITUTE FOR  
ENGINEERING AND TECHNOLOGY,  
K. S. R. KALVI NAGAR,  
TIRUCHENGODE - 637 215,  
NAMAKKAL DI, TAMIL NADU.

BATCH: 2016 - 2020

ACADEMIC YEAR: 2017 - 2018 (ODD)

DATE: 20.06.2017

## Fore Noon session

S.NO	BRANCH	STRENGTH	No of Placement Not Registered Students	PRESENT	ABSENT	Leave
1	CSE	47	47	38	6	3
2	ECE - A	42	42	34	8	-
3	ECE - B	42	42	38	4	-
4	EEE	47	47	44	3	-
5	IT	45	45	40	4	1
6	MECH - A	50	50	45	4	1
7	MECH - B	49	49	43	5	1
<b>Total</b>		<b>322</b>	<b>322</b>	<b>282</b>	<b>34</b>	<b>6</b>

## After Noon Session

S.NO	BRANCH	STRENGTH	No of Placement Not Registered Students	PRESENT	ABSENT	Leave
1	CSE	47	47	38	6	3
2	ECE - A	42	42	34	8	-
3	ECE - B	42	42	38	4	-
4	EEE	47	47	44	3	-
5	IT	45	45	40	4	1
6	MECH - A	50	50	45	4	1
7	MECH - B	49	49	43	5	1
<b>Total</b>		<b>322</b>	<b>322</b>	<b>282</b>	<b>34</b>	<b>6</b>

*[Signature]*  
T & P OFFICER

*[Signature]*  
T & P COORDINATOR

*[Signature]*  
PRINCIPAL

PRINCIPAL,  
K. S. R. INSTITUTE FOR  
ENGINEERING AND TECHNOLOGY,  
K. S. R. KALVI NAGAR,  
TIRUCHENGODE - 637 215,  
NAMAKKAL Dt, TAMIL NADU.

BATCH: 2016 - 2020

ACADEMIC YEAR: 2017 - 2018 (ODD)

DATE: 21.06.2017

## Fore Noon session

S.NO	BRANCH	STRENGTH	No of Placement Not Registered Students	PRESENT	ABSENT	Leave
1	CSE	47	47	34	8	5
2	ECE - A	42	42	33	7	2
3	ECE - B	42	42	39	3	-
4	EEE	47	47	42	5	-
5	IT	45	45	36	6	3
6	MECH - A	50	50	46	3	1
7	MECH - B	49	49	45	4	-
<b>Total</b>		<b>322</b>	<b>322</b>	<b>275</b>	<b>36</b>	<b>11</b>

## After Noon Session

S.NO	BRANCH	STRENGTH	No of Placement Not Registered Students	PRESENT	ABSENT	PERMISSION
1	CSE	47	47	35	7	5
2	ECE - A	42	42	33	6	3
3	ECE - B	42	42	38	4	-
4	EEE	47	47	44	3	-
5	IT	45	45	37	5	3
6	MECH - A	50	50	45	4	1
7	MECH - B	49	49	42	7	-
<b>Total</b>		<b>322</b>	<b>322</b>	<b>274</b>	<b>36</b>	<b>12</b>

*K. Kaluth*  
T & P OFFICER  
21/6

*[Signature]*  
T & P COORDINATOR

*[Signature]*  
PRINCIPAL

PRINCIPAL,  
K. S. R. INSTITUTE FOR  
ENGINEERING AND TECHNOLOGY,  
K. S. R. KALVI NAGAR,  
TIRUCHENGODE - 637 215,  
NAMAKKAL DI, TAMIL NADU.

BATCH: 2016 - 2020

ACADEMIC YEAR: 2017 - 2018 (ODD)

DATE: 22.06.2017

## Fore Noon session

S.NO	BRANCH	STRENGTH	No of Placement Not Registered Students	PRESENT	ABSENT	Leave
1	CSE	47	47	37	6	4
2	ECE - A	42	42	40	1	1
3	ECE - B	42	42	39	2	1
4	EEE	47	47	39	5	3
5	IT	45	45	42	3	-
6	MECH - A	50	50	44	4	2
7	MECH - B	49	49	45	4	-
<b>Total</b>		<b>322</b>	<b>322</b>	<b>286</b>	<b>25</b>	<b>11</b>

## After Noon Session

S.NO	BRANCH	STRENGTH	No of Placement Not Registered Students	PRESENT	ABSENT	PERMISSION
1	CSE	47	47	38	4	5
2	ECE - A	42	42	40	1	1
3	ECE - B	42	42	39	2	1
4	EEE	47	47	39	5	3
5	IT	45	45	42	3	-
6	MECH - A	50	50	45	3	2
7	MECH - B	49	49	45	4	-
<b>Total</b>		<b>322</b>	<b>322</b>	<b>288</b>	<b>22</b>	<b>12</b>

 T & P OFFICER

 T & P COORDINATOR

 PRINCIPAL

PRINCIPAL,  
 K. S. R. INSTITUTE FOR  
 ENGINEERING AND TECHNOLOGY,  
 K. S. R. KALVI NAGAR,  
 TIRUCHENGODE - 637 215,  
 NAMANGAL DA, TAMIL NADU.

BATCH: 2016 - 2020

ACADEMIC YEAR: 2017 - 2018 (ODD)

DATE: 23.06.2017

## Fore Noon session

S.NO	BRANCH	STRENGTH	No of Placement Not Registered Students	PRESENT	ABSENT	Leave
1	CSE	47	47	38	6	3
2	ECE - A	42	42	38	3	1
3	ECE - B	42	42	37	4	1
4	EEE	47	47	41	3	3
5	IT	45	45	41	3	1
6	MECH - A	50	50	45	4	1
7	MECH - B	49	49	47	2	-
<b>Total</b>		<b>322</b>	<b>322</b>	<b>287</b>	<b>25</b>	<b>10</b>

## After Noon Session

S.NO	BRANCH	STRENGTH	No of Placement Not Registered Students	PRESENT	ABSENT	Leave
1	CSE	47	47	39	5	3
2	ECE - A	42	42	38	3	1
3	ECE - B	42	42	37	3	2
4	EEE	47	47	41	5	1
5	IT	45	45	41	3	1
6	MECH - A	50	50	45	4	1
7	MECH - B	49	49	47	2	-
<b>Total</b>		<b>322</b>	<b>322</b>	<b>288</b>	<b>25</b>	<b>9</b>

*F. Kaluth*  
T & P OFFICER

*[Signature]*  
T & P COORDINATOR

*[Signature]*  
PRINCIPAL

PRINCIPAL,  
K. S. R. INSTITUTE FOR  
ENGINEERING AND TECHNOLOGY,  
K. S. R. KALVI NAGAR,  
TIRUCHENGODE - 637 215,  
NAMAKKAL DI, TAMIL NADU.

BATCH: 2016 - 2020

ACADEMIC YEAR: 2017 - 2018 (ODD)

DATE: 24.06.2017

## Fore Noon session

S.NO	BRANCH	STRENGTH	No of Placement Not Registered Students	PRESENT	ABSENT	Leave
1	CSE	47	47	36	6	5
2	ECE - A	42	42	33	8	1
3	ECE - B	42	42	35	4	3
4	EEE	47	47	29	18	-
5	IT	45	45	39	4	2
6	MECH - A	50	50	35	11	4
7	MECH - B	49	49	43	6	-
<b>Total</b>		<b>322</b>	<b>322</b>	<b>250</b>	<b>57</b>	<b>15</b>

## After Noon Session

S.NO	BRANCH	STRENGTH	No of Placement Not Registered Students	PRESENT	ABSENT	Leave
1	CSE	47	47	34	7	6
2	ECE - A	42	42	33	8	1
3	ECE - B	42	42	35	4	3
4	EEE	47	47	29	18	-
5	IT	45	45	38	5	2
6	MECH - A	50	50	33	13	4
7	MECH - B	49	49	43	6	-
<b>Total</b>		<b>322</b>	<b>322</b>	<b>245</b>	<b>61</b>	<b>16</b>

*[Signature]*  
T & P OFFICER

*[Signature]*  
T & P COORDINATOR

*[Signature]*  
PRINCIPAL

PRINCIPAL,  
K. S. R. INSTITUTE FOR  
ENGINEERING AND TECHNOLOGY,  
K. S. R. KALVINAGAR,  
TIRUCHENGODE - 637 215,  
NAMAKKAL DI, TAMIL NADU.

**K S R INSTITUTE FOR ENGINEERING AND TECHNOLOGY  
TIRUCHENGODE - 637 215**

**TRAINING PROGRAMME FEEDBACK FORM**



Name of the Student: N. Syed Salman

Branch: ECE

Year / Sem: II / III

1. Name of the Training : Placement

2. Name of the Trainer : Sivakumari

3. Students rating of Trainers : Good

S. No.	Date	Subject	Rating (✓)			
			Excellent	Very good	Good	Average
1	20.6.2017	Maths		✓		

4. Two positive points about the programme: 1) easy learning 2) very useful

5. Suggestions for improvement: explain deeply

Date: 20.6.2017

N. Syed Salman

Signature

**K S R INSTITUTE FOR ENGINEERING AND TECHNOLOGY  
TIRUCHENGODE - 637 215**

**TRAINING PROGRAMME FEEDBACK FORM**



Name of the Student: V. Bharathi

Branch: BE / MECHANICAL

Year / Sem: II<sup>nd</sup>, III<sup>rd</sup>

4. Name of the Training : Placement

5. Name of the Trainer : Sivakumari

6. Students rating of Trainers : Excellent

S. No.	Date	Subject	Rating (✓)			
			Excellent	Very good	Good	Average
1	20.6.2017	Maths		✓		

4. Two positive points about the programme: 1) easy learning 2) very useful

5. Suggestions for improvement: Explain in deep

Date: 20.6.17

PRINCIPAL,  
 K. S. R. INSTITUTE FOR  
 ENGINEERING AND TECHNOLOGY,  
 K. S. R. INSTITUTE FOR  
 TIRUCHENGODE - 637 215,  
 NAMAKKAL DISTRICT, TAMIL NADU.  
V. Bharathi  
 Signature



Name of the Student: Jswarya.P Branch: FCE

Year / Sem: II / III

1. Name of the Training: Soft skills / Grammar.

2. Name of the Trainer: P. Mohan.

3. Students rating of Trainers :

S. No.	Date	Subject	Rating (√)			
			Excellent	Very good	Good	Average
1	20/6/17	English				✓

4. Two positive points about the programme: \* Motivating students.  
\* Recalling grammar.

5. Suggestions for improvement: Can be more interesting.

Date: 20/6/17

Jswarya  
Signature

Name of the Student: Madhumitha.J.e Branch: EEE

Year / Sem: II / III

4. Name of the Training: soft skills / Grammar

5. Name of the Trainer: P. Mohan

6. Students rating of Trainers :

S. No.	Date	Subject	Rating (√)			
			Excellent	Very good	Good	Average
1	20/6/17	English				✓

4. Two positive points about the programme: ✓ Inspiring & motivating

5. Suggestions for improvement: can be more interesting

Date: 20/6/17

PRINCIPAL,  
K. S. R. INSTITUTE FOR  
ENGINEERING AND TECHNOLOGY,  
K. S. R. NAGAR,  
TIRUCHENGODE - 637 215,  
NAMAKKAL DI, TAMIL NADU.

[Signature]  
Signature

Name of the Student: R.S. VASU MITHA Branch: CSE

Year / Sem: II / II

1. Name of the Training: Soft skills & Grammar

2. Name of the Trainer: S. Nadhan

3. Students rating of Trainers :

S. No.	Date	Subject	Rating (✓)			
			Excellent	Very good	Good	Average
1	20.6.2017	Grammar		✓		

4. Two positive points about the programme: known more about online training & Grammar based activities

5. Suggestions for improvement:

Fun filled teaching



Date: 20.6.17

Signature

Name of the Student: K. Saraswathy Branch: B.Tech - IT

Year / Sem: II / II

4. Name of the Training: Soft skills & Grammar

5. Name of the Trainer: S. Madhan

6. Students rating of Trainers :

S. No.	Date	Subject	Rating (✓)			
			Excellent	Very good	Good	Average
1	20.6.2017	Grammar		✓		

4. Two positive points about the programme: learn more basics & Not boring

5. Suggestions for improvement:

Can be more

PRINCIPAL,  
K. S. R. INSTITUTE FOR  
ENGINEERING AND TECHNOLOGY,  
TIRUCHENGODE - 637 215,  
NAMAKKAL, TAMIL NADU.  
Signature

Date: 20.6.17

413 (FN)

K S R INSTITUTE FOR ENGINEERING AND TECHNOLOGY  
TIRUCHENGODE - 637 215



TRAINING PROGRAMME FEEDBACK FORM

Name of the Student: V. YUVA PRIYANKA

Branch: B.E/CSE

Year / Sem: II

1. Name of the Training: PARTS OF SPEECH

2. Name of the Trainer: KANAGIA VEL

3. Students rating of Trainers :

S. No.	Date	Subject	Rating (√)			
			Excellent	Very good	Good	Average
1	20/6/17	English	✓			

4. Two positive points about the programme: Super and mind concept Program.

5. Suggestions for improvement: Knowledge developed.

Date: 20/6/17

V. Yuva Priya  
Signature

K S R INSTITUTE FOR ENGINEERING AND TECHNOLOGY  
TIRUCHENGODE - 637 215



TRAINING PROGRAMME FEEDBACK FORM

413 (FN)

Name of the Student: R.A. Nany Dsmitha

Branch: B.E/EEF

Year / Sem: II

4. Name of the Training: Grammar

5. Name of the Trainer: Monjagan

6. Students rating of Trainers :

S. No.	Date	Subject	Rating (√)			
			Excellent	Very good	Good	Average
1	20/6/17	English	✓			

4. Two positive points about the programme: Well developed Skill

5. Suggestions for improvement: improved Knowledge

Date: 20/6/17

PRINCIPAL,  
K. S. R. INSTITUTE FOR  
ENGINEERING AND TECHNOLOGY,  
K. S. R. KALVI NAGAR,  
TIRUCHENGODE - 637 215,  
NAMAKKAL Dt, TAMIL NADU.  
Signature

Nany Dsmitha



413 (AN)

Name of the Student: Y. Joshua Branch: Mechanical

Year / Sem: II / II

1. Name of the Training: Workshop / P SOFT SKILL [GRAMMER]

2. Name of the Trainer: Mohan.P

3. Students rating of Trainers :

S. No.	Date	Subject	Rating (✓)			
			Excellent	Very good	Good	Average
1	20/6/17	English			✓	

4. Two positive points about the programme: developing grammar skill  
developing self confidence

5. Suggestions for improvement:

Date:

PRINCIPAL,  
K. S. R. INSTITUTE FOR  
ENGINEERING AND TECHNOLOGY,  
K. S. R. KALVI NAGAR,  
TIRUCHENGODE - 637 215,  
TAMIL NADU, INDIA

Y. P. S.  
Signature



Name of the Student: \_\_\_\_\_ Branch: \_\_\_\_\_

Year / Sem:

4. Name of the Training :

5. Name of the Trainer :

6. Students rating of Trainers :

S. No.	Date	Subject	Rating (✓)			
			Excellent	Very good	Good	Average
1						

4. Two positive points about the programme:

5. Suggestions for improvement:

Date:

Signature

Name of the Student: S. Ilakija.

Branch: CSE

Year / Sem: II / 03.

1. Name of the Training: Soft skills.

2. Name of the Trainer: Mr. Muhuntharaj.

3. Students rating of Trainers :

S. No.	Date	Subject	Rating (✓)			
			Excellent	Very good	Good	Average
1	20.06.17	Soft skills	✓			

4. Two positive points about the programme:

Improving our soft skills.

Motivating our self confidence.

5. Suggestions for improvement:

Date: 20.06.17

S. Ilakija  
Signature

Name of the Student: S. Ragavendhar

Branch: MECH - B

Year / Sem: II / 03

4. Name of the Training: Soft Skills

5. Name of the Trainer: Mr. Muhuntharaj

6. Students rating of Trainers :

S. No.	Date	Subject	Rating (✓)			
			Excellent	Very good	Good	Average
1	20.06.17	Soft Skills	✓			

4. Two positive points about the programme:

Helps to improve our self confidence

5. Suggestions for improvement:

Date: 20.06.17

PRINCIPAL,  
K. S. R. INSTITUTE FOR  
ENGINEERING AND TECHNOLOGY,  
K. S. R. KALM NAGAR,  
TIRUCHENGODE - 637 215,  
NAMAKKAL Dt, TAMIL NADU.

S. Ravi  
Signature

Name of the Student: R.H. Sakthi Ganesa Sundaram Branch: Mechanical - B

Year / Sem: 02 :- 03 :-

1. Name of the Training: Placement Training.

2. Name of the Trainer: Jayakumar.

3. Students rating of Trainers :

S. No.	Date	Subject	Rating (√)			
			Excellent	Very good	Good	Average
1	20.06.17	MTaths		✓		

4. Two positive points about the programme: i) Clear explanation.  
ii) Easy understanding.

5. Suggestions for improvement:

i) Nothing.

Date:

Signature

Name of the Student: M. BRINDHA Branch: ECE

Year / Sem: 2<sup>nd</sup> / 2<sup>nd</sup>

4. Name of the Training: PLACEMENT TRAINING

5. Name of the Trainer: JAYAKUMAR

6. Students rating of Trainers :

S. No.	Date	Subject	Rating (√)			
			Excellent	Very good	Good	Average
1	20.06.17	MATHS	✓			

4. Two positive points about the programme:

EASILY UNDERSTANDING  
PERFECT CLARIFICATION

5. Suggestions for improvement:

NOTHING

Date: 20/6/17 (FN)

PRINCIPAL,  
K. S. R. INSTITUTE FOR  
ENGINEERING AND TECHNOLOGY,  
K. S. R. KALYANAGAI  
TIRUCHENGODE - 637 215,  
NAMAKKAL DI, TAMIL NADU.  
Signature Brindha. M

30%

K S R INSTITUTE FOR ENGINEERING AND TECHNOLOGY  
TIRUCHENGODE - 637 215

TRAINING PROGRAMME FEEDBACK FORM



FN.

Name of the Student: J. MANESWARAN

Branch: ECE

Year / Sem: II / III

1. Name of the Training: Aptitude

2. Name of the Trainer: Kumaravel

3. Students rating of Trainers :

S. No.	Date	Subject	Rating (✓)			
			Excellent	Very good	Good	Average
1	20.06.2017	MATHS		✓		

4. Two positive points about the programme:

very good explanation.  
easily understood.

5. Suggestions for improvement:

*[Handwritten signature]*

Signature

Date:

K S R INSTITUTE FOR ENGINEERING AND TECHNOLOGY  
TIRUCHENGODE - 637 215

TRAINING PROGRAMME FEEDBACK FORM



Name of the Student: K. Mohan Arjun

Branch: Mech

Year / Sem: II

4. Name of the Training: Aptitude

5. Name of the Trainer: Kumaravel

6. Students rating of Trainers :

S. No.	Date	Subject	Rating (✓)			
			Excellent	Very good	Good	Average
1	20-06-17	maths		✓		

4. Two positive points about the programme:

understood easily,  
mostly helpful.

5. Suggestions for improvement:

Date: 20-06-2017

PRINCIPAL,  
K. S. R. INSTITUTE FOR  
ENGINEERING AND TECHNOLOGY,  
K. S. P. KALYAN NAGAR,  
TIRUCHENGODE - 637 215, Signature  
NAMAKKAL Dt, TAMIL NADU.

305



TRAINING PROGRAMME FEEDBACK FORM

Name of the Student: N. Karthika

Branch: B.Tech (IT)

Year / Sem: II / III

1. Name of the Training: Appitude

2. Name of the Trainer: Jayakumar

3. Students rating of Trainers :

S. No.	Date	Subject	Rating (✓)			
			Excellent	Very good	Good	Average
1	20.06.17	Maths		✓		

4. Two positive points about the programme:

The programme is very useful for student

5. Suggestions for improvement:

No suggestions.

Date: 20.06.17

N. Karthika  
Signature



TRAINING PROGRAMME FEEDBACK FORM

Name of the Student: S. Sarath

Branch: Med-B

Year / Sem: II / III

4. Name of the Training: Appitude

5. Name of the Trainer: Jayakumar

6. Students rating of Trainers :

S. No.	Date	Subject	Rating (✓)			
			Excellent	Very good	Good	Average
1	20/6/17	Maths			✓	

4. Two positive points about the programme:

Like Gaining knowledge  
Like Interesting

5. Suggestions for improvement:

More Teaching  
Jolly Teaching

Date: 20/6/17

PRINCIPAL,  
K. S. R. INSTITUTE FOR  
ENGINEERING AND TECHNOLOGY,  
K. S. R. KALYANAGAR,  
TIRUCHENGODE - 637 215,  
NAMAKKAL DISTRICT, TAMIL NADU.  
[Signature]  
Signature



409  
FN

K S R INSTITUTE FOR ENGINEERING AND TECHNOLOGY  
TIRUCHENGODE - 637 215

TRAINING PROGRAMME FEEDBACK FORM



Name of the Student: V. Sarithash Kumar

Branch: Mechanical

Year / Sem: V / I

1. Name of the Training :

2. Name of the Trainer : T. Viji

3. Students rating of Trainers :

S. No.	Date	Subject	Rating (√)			
			Excellent	Very good	Good	Average
1	21/06/17	ENGLISH	✓			

4. Two positive points about the programme:

Motivation

5. Suggestions for improvement:

Date: 21/06/17

[Signature]  
Signature

K S R INSTITUTE FOR ENGINEERING AND TECHNOLOGY  
TIRUCHENGODE - 637 215

TRAINING PROGRAMME FEEDBACK FORM



Name of the Student: R. BAHAJI

Branch: ECE

Year / Sem: II / III

4. Name of the Training :

5. Name of the Trainer : Viji

6. Students rating of Trainers :

S. No.	Date	Subject	Rating (√)			
			Excellent	Very good	Good	Average
1	21/6/17	conversation sentences		✓		

4. Two positive points about the programme: → Nice, Not bored.

→ Clearly understandable.

5. Suggestions for improvement:

Date: 21/6/17

PRINCIPAL,  
K. S. R. INSTITUTE FOR  
ENGINEERING AND TECHNOLOGY,  
K. S. R. KALVIHAGAR,  
TIRUCHENGODE - 637 215,  
NAMAKKAL DI, TAMIL NADU.

[Signature]  
Signature

**K S R INSTITUTE FOR ENGINEERING AND TECHNOLOGY  
TIRUCHENGODE - 637 215**

**TRAINING PROGRAMME FEEDBACK FORM**



708  
(FN)

Name of the Student: S. SAKTHIPRIYA

Branch: ECF

Year / Sem: II / II

1. Name of the Training: Number system

2. Name of the Trainer: DEVASRI

3. Students rating of Trainers :

S. No.	Date	Subject	Rating (✓)			
			Excellent	Very good	Good	Average
1	20.6.17	MATHS	✓			

4. Two positive points about the programme: we can understand easily

5. Suggestions for improvement:

Date: 20.6.17

*Sakthipriya S*  
Signature

**K S R INSTITUTE FOR ENGINEERING AND TECHNOLOGY  
TIRUCHENGODE - 637 215**

**TRAINING PROGRAMME FEEDBACK FORM**



405  
(FN)

Name of the Student: D. Praveen

Branch: B.E/EEE

Year / Sem: 2<sup>nd</sup> year / III<sup>rd</sup> sem

4. Name of the Training: Number system

5. Name of the Trainer: Deviasi

6. Students rating of Trainers :

S. No.	Date	Subject	Rating (✓)			
			Excellent	Very good	Good	Average
1	20.6.17	Maths	✓			

4. Two positive points about the programme:

5. Suggestions for improvement:

Date: 20.6.17

  
 PRINCIPAL,  
 K. S. R. INSTITUTE FOR  
 ENGINEERING AND TECHNOLOGY,  
 K. S. R. KALVI NAGAR,  
 TIRUCHENGODE - 637 215,  
 NAMANKAL DI, TAMIL NADU

*D. Praveen*  
Signature

**K S R INSTITUTE FOR ENGINEERING AND TECHNOLOGY  
TIRUCHENGODE - 637 215**

**TRAINING PROGRAMME FEEDBACK FORM**



405  
AN

Name of the Student: V. YAKSHITHA

Branch: R.TECH/IT

Year / Sem: II / III

1. Name of the Training : WORK shed time

2. Name of the Trainer : Suresh

3. Students rating of Trainers :

S. No.	Date	Subject	Rating (√)			
			Excellent	Very good	Good	Average
1	20.6.17	MATHS	✓			

4. Two positive points about the programme:

5. Suggestions for improvement:

?

?

Date: 20.6.17

*V. Yakshitha*  
Signature

**K S R INSTITUTE FOR ENGINEERING AND TECHNOLOGY  
TIRUCHENGODE - 637 215**

**TRAINING PROGRAMME FEEDBACK FORM**



405  
AN

Name of the Student: C. Rahul

Branch: Mechanical Engineering

Year / Sem: II / III

4. Name of the Training : Work & Time

5. Name of the Trainer : Suresh

6. Students rating of Trainers :

S. No.	Date	Subject	Rating (√)			
			Excellent	Very good	Good	Average
1	20.6.17	MATHS	✓			

4. Two positive points about the programme:

\* good interested created.

5. Suggestions for improvement:

Date: 20.6.17

PRINCIPAL,  
K. S. R. INSTITUTE FOR  
ENGINEERING AND TECHNOLOGY,  
K. S. R. KALAI NAGAR,  
TIRUCHENGODE - 637 215,  
NARAYANAPURAM, TAMIL NADU.

*C. Rahul*  
Signature



408  
AN

Name of the Student: T. Chellathurai

Branch: Mech-A

Year / Sem: II / II

1. Name of the Training: Soft Skills

2. Name of the Trainer: Kangase/Vam.

3. Students rating of Trainers :

S. No.	Date	Subject	Rating (✓)			
			Excellent	Very good	Good	Average
1	20/6/17	Puzzle word search story completion	✓	✓		

4. Two positive points about the programme:

Not Boring, Very fun

5. Suggestions for improvement:

nothing

Date: 20/6/17

[Signature]  
Signature



408  
AN

Name of the Student: DHIVYA

Branch: ECE

Year / Sem: III 2017

4. Name of the Training: PLACEMENT TRAINING

5. Name of the Trainer: P. GIRINAGRAVEL

6. Students rating of Trainers :

S. No.	Date	Subject	Rating (✓)			
			Excellent	Very good	Good	Average
1	20/6/17	English		✓		

4. Two positive points about the programme:

\* Knowing new Vocabulary  
\* Inter skills  
\* Writing

5. Suggestions for improvement:

\* Interval should need.

Date: 20.6.17

[Signature]  
Signature

K S R INSTITUTE FOR ENGINEERING AND TECHNOLOGY  
TIRUCHENGODE - 637 215

TRAINING PROGRAMME FEEDBACK FORM



FN

Name of the Student: Priyanka.c

Branch: ECE

Year / Sem: II<sup>nd</sup> 2017 / III

1. Name of the Training: conversation

2. Name of the Trainer: Mr. vij

3. Students rating of Trainers: 20/6/17 B

S. No.	Date	Subject	Rating (√)			
			Excellent	Very good	Good	Average
1	20.06.17	English	✓			

4. Two positive points about the programme:

Good communication and stage fear

5. Suggestions for improvement:

Nil

Date: 20.6.17

C. D. Jeyaraj  
Signature

K S R INSTITUTE FOR ENGINEERING AND TECHNOLOGY  
TIRUCHENGODE - 637 215

TRAINING PROGRAMME FEEDBACK FORM



FN

Name of the Student: S. Mounika

Branch: IT

Year / Sem: I yr / 3

4. Name of the Training: conversation

5. Name of the Trainer: Mr. Vij

6. Students rating of Trainers: 5

S. No.	Date	Subject	Rating (√)			
			Excellent	Very good	Good	Average
1	20.6.17	English	✓			

4. Two positive points about the programme:

Good communication  
reduce stage fear.

5. Suggestions for improvement:

Nil

Date: 20.6.17

S. M. Jeyaraj  
Signature

Signature

A.N: (312)

TRAINING PROGRAMME FEEDBACK FORM

Name of the Student: V. Vijay

Branch: B. Tech C17

Year / Sem: 11<sup>th</sup> / III<sup>rd</sup>

4. Name of the Training: Communication Skill

5. Name of the Trainer: T. Viji

6. Students rating of Trainers: 4 1/2 stars

S. No.	Date	Subject	Rating (✓)			
			Excellent	Very good	Good	Average
1	20.06.17	ENGLISH		✓		

4. Two positive points about the programme:

Activity, Communication Skill.

5. Suggestions for improvement:

- Nil -

Date: 20-6-17

Signature



A.N (312)

TRAINING PROGRAMME FEEDBACK FORM

Name of the Student: P. Gowtham

Branch: Mechanical

Year / Sem: II / II

1. Name of the Training: Communication

2. Name of the Trainer: Viji

3. Students rating of Trainers: 4 stars

S. No.	Date	Subject	Rating (✓)			
			Excellent	Very good	Good	Average
1	20.6.17	English	✓			

4. Two positive points about the programme: Personality Development

5. Suggestions for improvement: Nil

Date: 20.6.17

Signature





Name of the Student: A. Raja Rajan

Branch: CSE

Year / Sem: II / III

1. Name of the Training : placement training

2. Name of the Trainer : N. Selvaraj

3. Students rating of Trainers :

S. No.	Date	Subject	Rating (√)			
			Excellent	Very good	Good	Average
1	20.06.17	APPITUDE (B.S&T)		✓		

4. Two positive points about the programme: It is very usefull, and it reduces the burden. It is quite usefull to train ourself for competative exams.

5. Suggestions for improvement:

Batch separation is comfortable for the student.

Date: 20.06.17

A. R. Rajan  
Signature



Name of the Student: NIVETHA.T

Branch: ECE - B

Year / Sem: II Year / 3

1. Name of the Training : PLACEMENT

2. Name of the Trainer : RAJESHANDRAN N. SELVARAJ

3. Students rating of Trainers :

S. No.	Date	Subject	Rating (√)			
			Excellent	Very good	Good	Average
1	20.06.2017	MATHS			✓	

4. Two positive points about the programme: Way of approach.

Displaying PPT and Working Problems

5. Suggestions for improvement: NIL

Date: 20/06/2017

T. Divyaja  
Signature

Batch separation is uncomfortable to the student. A.K. Juv

Signature

Date: 20.06.17

K S R I NSTITUTE FOR ENGINEERING AND TECHNOLOGY  
TIRUCHENGODE - 637 215  
TRAINING PROGRAMME FEEDBACK FORM

AN 403



Name of the Student: NIVETHA T

Branch: ECE - B

Year / Sem: II year / ODD

4. Name of the Training: PLACEMENT

5. Name of the Trainer: KUMARAVELU

6. Students rating of Trainers :

S. No.	Date	Subject	Rating (√)			
			Excellent	Very good	Good	Average
1	20/6/2017	Maths.				✓

4. Two positive points about the programme: Nil.

5. Suggestions for improvement: Ppt is not used properly. Interaction is very less.

Date: 20/6/2017.

Signature

PRINCIPAL,  
K. S. R. INSTITUTE FOR  
ENGINEERING AND TECHNOLOGY,  
K. S. R. KALVI NAGAR,  
TIRUCHENGODE - 637 215,  
NAMAKKAL DISTRICT, TAMIL NADU.





Name of the Student: D. Gowri

Branch: IT

Year / Sem: II / 03

4. Name of the Training: Placement training

5. Name of the Trainer: Mr. Vijayaraj

6. Students rating of Trainers :

S. No.	Date	Subject	Rating (√)			
			Excellent	Very good	Good	Average
1	21.6.17	Time & Work		✓		

4. Two positive points about the programme:  
Topic was taught clearly and able to apply easily

5. Suggestions for improvement:

Date: 21.6.17

[Signature]  
Signature



Name of the Student: KANIMOZHI V

Branch: EEE

Year / Sem: II / III

1. Name of the Training: Probability

2. Name of the Trainer: Jayakumar

3. Students rating of Trainers :

S. No.	Date	Subject	Rating (√)			
			Excellent	Very good	Good	Average
1	21.6.17	Maths		✓		

4. Two positive points about the programme:

5. Suggestions for improvement:

PRINCIPAL,  
K. S. R. INSTITUTE FOR  
ENGINEERING AND TECHNOLOGY,  
K. S. R. KALYANAGAR,  
TIRUCHENGODE - 637 215,  
NAMAKKAL DK, TAMIL NADU.

[Signature]  
Signature

713 AN

Name of the Student: P. Mohanraj

Branch: B.Tech / IT

Year / Sem: II / I

4. Name of the Training :

5. Name of the Trainer : Mr. Madhan.

6. Students rating of Trainers :

S. No.	Date	Subject	Rating (✓)			
			Excellent	Very good	Good	Average
1	21/6/17	English		✓		

4. Two positive points about the programme:

conducting activities & making it comfortable.

5. Suggestions for improvement:

Date: 21/6/17.

  
Signature

PRINCIPAL,  
K. S. R. INSTITUTE FOR  
ENGINEERING AND TECHNOLOGY,  
K. S. R. KALVI NAGAR,  
TIRUCHENGODE - 637 215,  
NAMAKKAL DI, TAMIL NADU.

312 FN

**K S R INSTITUTE FOR ENGINEERING AND TECHNOLOGY**  
TIRUCHENGODE - 637 215

**TRAINING PROGRAMME FEEDBACK FORM**



Name of the Student: Jayavarshini G Branch: CSE

Year / Sem: II / III

1. Name of the Training: Mohan (Activity)

2. Name of the Trainer: Mohan

3. Students rating of Trainers: 4

S. No.	Date	Subject	Rating (√)			
			Excellent	Very good	Good	Average
1	21.07.17	English	✓			

4. Two positive points about the programme:  
The activity is useful  
Enjoyful, not Boring

5. Suggestions for improvement:

Date: 21.07.2017

Jayavarshini G  
Signature

**K S R INSTITUTE FOR ENGINEERING AND TECHNOLOGY**  
TIRUCHENGODE - 637 215

**TRAINING PROGRAMME FEEDBACK FORM**



Name of the Student: Vignesh P Branch: ECE

Year / Sem: II<sup>nd</sup> year / III<sup>rd</sup> sem

4. Name of the Training: Grammar

5. Name of the Trainer: Mohan Sir,

6. Students rating of Trainers:

S. No.	Date	Subject	Rating (√)			
			Excellent	Very good	Good	Average
1	21.07.17	English	✓			

4. Two positive points about the programme:  
Very useful program

5. Suggestions for improvement:

Date: 21.07.17.

PRINCIPAL,  
K. S. R. INSTITUTE FOR  
ENGINEERING AND TECHNOLOGY,  
K. S. R. KALVI NAGAR,  
TIRUCHENGODE - 637 215,  
NAMAKKAL DISTRICT, TAMIL NADU.  
P. Vignesh  
Signature

30.5 FN

**K S R INSTITUTE FOR ENGINEERING AND TECHNOLOGY  
TIRUCHENGODE - 637 215**

**TRAINING PROGRAMME FEEDBACK FORM**



Name of the Student: V. Subash Branch: FCE

Year / Sem: II / III

1. Name of the Training :

2. Name of the Trainer :

3. Students rating of Trainers :

S. No.	Date	Subject	Rating (√)			
			Excellent	Very good	Good	Average
1	21.6.17	Maths			✓	

4. Two positive points about the programme:

*It helped to recall all the basic Maths*

5. Suggestions for improvement:

*No suggestions*

*V. Subash*

Date:

Signature

**K S R INSTITUTE FOR ENGINEERING AND TECHNOLOGY  
TIRUCHENGODE - 637 215**

**TRAINING PROGRAMME FEEDBACK FORM**



Name of the Student: M. AJITH KUMAR Branch: IT

Year / Sem: II / III

4. Name of the Training :

5. Name of the Trainer :

6. Students rating of Trainers :

S. No.	Date	Subject	Rating (√)			
			Excellent	Very good	Good	Average
1	21/6/17	MATHS			✓	

4. Two positive points about the programme:

*It is very helpful to placement class*

5. Suggestions for improvement:

*No suggestions.*

PRINCIPAL,  
K. S. R. INSTITUTE FOR  
ENGINEERING AND TECHNOLOGY,  
K. S. R. KALVA NAGAR,  
TIRUCHENGODE - 637 215,  
NAMAKKAL Dt, TAMIL NADU.

*M. D. Raj*  
Signature

Date:

K S R INSTITUTE FOR ENGINEERING AND TECHNOLOGY  
TIRUCHENGODE - 637 215

TRAINING PROGRAMME FEEDBACK FORM



Name of the Student: M. Priyadharshini Branch: ECF

Year / Sem: 2017 / III

1. Name of the Training: Sentence pattern, voices, parts of speech

2. Name of the Trainer: Mohan

3. Students rating of Trainers :

S. No.	Date	Subject	Rating (✓)			
			Excellent	Very good	Good	Average
1	21.6.2017	English	✓			

4. Two positive points about the programme:

More idea this topics, very usefull this topic

5. Suggestions for improvement: improvement No

Date: 21.6.2017

Signature M. Priyadharshini

K S R INSTITUTE FOR ENGINEERING AND TECHNOLOGY  
TIRUCHENGODE - 637 215

TRAINING PROGRAMME FEEDBACK FORM



Name of the Student: M. Sakthi Ravi Kumar Branch: IT

Year / Sem: II / III

4. Name of the Training: Sentence Pattern, voices, parts of speech.

5. Name of the Trainer: Mohan

6. Students rating of Trainers :

S. No.	Date	Subject	Rating (✓)			
			Excellent	Very good	Good	Average
1	21.06.2017	English	✓			

4. Two positive points about the programme:

To avoid fear in class to give any instructions.

5. Suggestions for improvement: will

Date: 21-6-2017

PRINCIPAL,  
K. S. R. INSTITUTE FOR  
ENGINEERING AND TECHNOLOGY,  
K. S. R. KALVI NAGAR,  
TIRUCHENGODE - 637 215,  
NARAIKAL DA, TAMIL NADU.

Signature M. Ravi Kumar

→ N (312)

K S R INSTITUTE FOR ENGINEERING AND TECHNOLOGY  
TIRUCHENGODE - 637 215



TRAINING PROGRAMME FEEDBACK FORM

Name of the Student: G. Boopalan

Branch: B-Tech(IT)

Year / Sem: II

1. Name of the Training: Communication skill

2. Name of the Trainer: mohan.P

3. Students rating of Trainers: 5

S. No.	Date	Subject	Rating (√)			
			Excellent	Very good	Good	Average
1	21.6.17	English	✓			

4. Two positive points about the programme:

Very useful program

5. Suggestions for improvement:

- nil -

Date: 21.6.17

G. Boopalan.  
Signature

K S R INSTITUTE FOR ENGINEERING AND TECHNOLOGY  
TIRUCHENGODE - 637 215



TRAINING PROGRAMME FEEDBACK FORM

Name of the Student: P. Vignesh

Branch: ELF

Year / Sem: IIIrd year / IIIrd sem

4. Name of the Training: Communication Activity.

5. Name of the Trainer: Mr. Mohan.P

6. Students rating of Trainers: 5

S. No.	Date	Subject	Rating (√)			
			Excellent	Very good	Good	Average
1	21.06.17	English	✓			

4. Two positive points about the programme:

Very useful, and got more talents on English.  
Thank You.

5. Suggestions for improvement:

Nil

Date: 21.6.17,

PRINCIPAL,  
K. S. R. INSTITUTE FOR  
ENGINEERING AND TECHNOLOGY,  
K. S. R. KALVI NAGAR,  
TIRUCHENGODE - 637 215,  
NARANKAL DI, TAMIL NADU.

P. Vignesh.  
Signature

**K S R INSTITUTE FOR ENGINEERING AND TECHNOLOGY  
TIRUCHENGODE - 637 215**

**TRAINING PROGRAMME FEEDBACK FORM**



FN

Name of the Student: R. Jeevitha

Branch: CSE

Year / Sem: II / III

1. Name of the Training : Appitude

2. Name of the Trainer : Devisri

3. Students rating of Trainers :

S. No.	Date	Subject	Rating (√)			
			Excellent	Very good	Good	Average
1	21.6.17	Maths			✓	

4. Two positive points about the programme:

1. It was very useful to us for developing my knowledge.
2. It makes our brain very useful.

5. Suggestions for improvement:

Work outing more problems to improve our knowledge

Date: 21.6.17

R. Jeevitha  
Signature

**K S R INSTITUTE FOR ENGINEERING AND TECHNOLOGY  
TIRUCHENGODE - 637 215**

**TRAINING PROGRAMME FEEDBACK FORM**



403  
Am

Name of the Student: P. Jeevitha

Branch: CSE

Year / Sem: II / III

4. Name of the Training : Appitude

5. Name of the Trainer : Devisri

6. Students rating of Trainers :

S. No.	Date	Subject	Rating (√)			
			Excellent	Very good	Good	Average
1	21.6.17	Maths			✓	

4. Two positive points about the programme:

1. It was very good for students.

5. Suggestions for improvement:

Give more problems to give solving

Date: 21.6.17

PRINCIPAL,  
K. S. R. INSTITUTE FOR  
ENGINEERING AND TECHNOLOGY,  
K. S. R. KALVI NAGAR,  
TIRUCHENGODE - 637 215,  
NAMAKKAL DL, TAMIL NADU.

R. Jeevitha  
Signature

K S R INSTITUTE FOR ENGINEERING AND TECHNOLOGY  
TIRUCHENGODE - 637 215

TRAINING PROGRAMME FEEDBACK FORM



Name of the Student: ~~Abhishek~~ Ahamed Fajil Branch: IT

Year / Sem: II / II

1. Name of the Training: Test

2. Name of the Trainer :

3. Students rating of Trainers :

S. No.	Date	Subject	Rating (√)			
			Excellent	Very good	Good	Average
1	21.6.17	Maths	✓			

4. Two positive points about the programme:

It is useful for placement training.

5. Suggestions for improvement:

Date: 21/6/17

Signature

K S R INSTITUTE FOR ENGINEERING AND TECHNOLOGY  
TIRUCHENGODE - 637 215

TRAINING PROGRAMME FEEDBACK FORM



Name of the Student: MATHURAJAN.S Branch: EE / BEB

Year / Sem: II / II

4. Name of the Training: Test

5. Name of the Trainer :

6. Students rating of Trainers :

S. No.	Date	Subject	Rating (√)			
			Excellent	Very good	Good	Average
1	21.6.17	Maths	✓			

4. Two positive points about the programme:

Very useful

5. Suggestions for improvement:

Date: 21/6/17

Signature

PRINCIPAL,  
K. S. R. INSTITUTE FOR  
ENGINEERING AND TECHNOLOGY,  
K. S. R. KALUTHAGAR,  
TIRUCHENGODE - 637 215,  
NAMAKKAL DI, TAMIL NADU.



413 AN

K S R INSTITUTE FOR ENGINEERING AND TECHNOLOGY  
TIRUCHENGODE - 637 215

TRAINING PROGRAMME FEEDBACK FORM



Name of the Student: G. Dhanatharshini

Branch: ECE - A

Year / Sem: II / I

1. Name of the Training: Basic Grammar

2. Name of the Trainer: Mr. Madhan

3. Students rating of Trainers :

S. No.	Date	Subject	Rating (✓)			
			Excellent	Very good	Good	Average
1	21.6.17	Basic Grammar		✓		

4. Two positive points about the programme: 1) Not boring.  
2) Very usefull.

5. Suggestions for improvement: Activity Questions can be quite harder.

Date: 21.6.17

PRINCIPAL,  
K. S. R. INSTITUTE FOR  
ENGINEERING AND TECHNOLOGY,  
K. S. R. KALVINAGAR,  
TIRUCHENGODE - 637 215,  
TAMIL NADU.

G. Dhanatharshini  
Signature

K S R INSTITUTE FOR ENGINEERING AND TECHNOLOGY  
TIRUCHENGODE - 637 215

TRAINING PROGRAMME FEEDBACK FORM



Name of the Student: \_\_\_\_\_

Branch: \_\_\_\_\_

Year / Sem: \_\_\_\_\_

4. Name of the Training :

5. Name of the Trainer :

6. Students rating of Trainers :

S. No.	Date	Subject	Rating (✓)			
			Excellent	Very good	Good	Average
1						

4. Two positive points about the programme:

5. Suggestions for improvement:

Date:

Signature

K S R INSTITUTE FOR ENGINEERING AND TECHNOLOGY  
TIRUCHENGODE - 637 215



TRAINING PROGRAMME FEEDBACK FORM

Name of the Student: S. Dakshya

Branch: ECE

Year / Sem: III - 1<sup>st</sup> year

1. Name of the Training: Assesment

2. Name of the Trainer: Madhan

3. Students rating of Trainers :

S. No.	Date	Subject	Rating (✓)			
			Excellent	Very good	Good	Average
1	21/06/17	Group Discussion	✓			

4. Two positive points about the programme:

Marvellous  
Taught Grammar without boring

5. Suggestions for improvement:

Date:

S. Dakshya  
Signature

K S R INSTITUTE FOR ENGINEERING AND TECHNOLOGY  
TIRUCHENGODE - 637 215



TRAINING PROGRAMME FEEDBACK FORM

Name of the Student: S. Ve. Pu. Prabha

Branch: CSE

Year / Sem: II / 1<sup>st</sup> Sem

4. Name of the Training: Assesment

5. Name of the Trainer: Madhan

6. Students rating of Trainers :

S. No.	Date	Subject	Rating (✓)			
			Excellent	Very good	Good	Average
1	21.06.2017	Group discussion	✓			

4. Two positive points about the programme: Freedom talks

Excellence to

5. Suggestions for improvement:

Date:

PRINCIPAL,  
K. S. R. INSTITUTE FOR  
ENGINEERING AND TECHNOLOGY,  
K. S. R. KALU NAGAR,  
TIRUCHENGODE - 637 215,  
NAMAKKAL DISTRICT, TAMIL NADU.

S. Ve. Pu. Prabha  
Signature

K S R INSTITUTE FOR ENGINEERING AND TECHNOLOGY  
TIRUCHENGODE - 637 215

TRAINING PROGRAMME FEEDBACK FORM



Name of the Student: Gowri . S

Branch: CSE

Year / Sem: II / III

1. Name of the Training: Revision and test

2. Name of the Trainer: Selvaraj

3. Students rating of Trainers :

S. No.	Date	Subject	Rating (√)			
			Excellent	Very good	Good	Average
1	21.06.2017	Maths	✓			

4. Two positive points about the programme:

5. Suggestions for improvement:

Date: 21.06.2017

S. Gowri  
Signature

K S R INSTITUTE FOR ENGINEERING AND TECHNOLOGY  
TIRUCHENGODE - 637 215

TRAINING PROGRAMME FEEDBACK FORM



Name of the Student: G. Tamilanathan

Branch: IT

Year / Sem: II 3rd sem

4. Name of the Training: Revision / Test

5. Name of the Trainer: Selvaraj

6. Students rating of Trainers :

S. No.	Date	Subject	Rating (√)			
			Excellent	Very good	Good	Average
1	21.6.17	Maths	✓			

4. Two positive points about the programme:

5. Suggestions for improvement:

Date: 21.6.17

S. Selvaraj  
Signature

PRINCIPAL,  
K. S. R. INSTITUTE FOR  
ENGINEERING AND TECHNOLOGY,  
K. S. R. KALVI NAGAR,  
TIRUCHENGODE - 637 215,  
NAMAKKAL Dt, TAMIL NADU.



Name of the Student: V. Priyanka Branch: CSE

Year / Sem: II / III

1. Name of the Training : SIVAKUMAR NUMBER SYSTEM

2. Name of the Trainer : SIVAKUMAR

3. Students rating of Trainers : 10

S. No.	Date	Subject	Rating (√)			
			Excellent	Very good	Good	Average
1	22.06.17	MATHS	✓			

4. Two positive points about the programme:

WELL COACHING

5. Suggestions for improvement:

NIL

Date: 22.06.17

V. Priyanka  
Signature



Name of the Student: S. Mohanraj Branch: EEE

Year / Sem: II / III

4. Name of the Training : NUMBER SYSTEM

5. Name of the Trainer : SIVA KUMAR

6. Students rating of Trainers : 10

S. No.	Date	Subject	Rating (√)			
			Excellent	Very good	Good	Average
1	22.6.17	MATHS	✓			

4. Two positive points about the programme:

WELL COACHING, NICE PRESENTATION

5. Suggestions for improvement:

NIL

Date: 22.06.17

PRINCIPAL,  
K. S. R. INSTITUTE FOR  
ENGINEERING AND TECHNOLOGY,  
K. S. R. KALAI NAGAR,  
TIRUCHENGODE - 637 215,  
NAMAKKAL DISTRICT, TAMIL NADU.

S. Mohanraj  
Signature

4070710

**K S R INSTITUTE FOR ENGINEERING AND TECHNOLOGY  
TIRUCHENGODE - 637 215**



**TRAINING PROGRAMME FEEDBACK FORM**

Name of the Student: Priyanka S

Branch: FCE

Year / Sem: II / III

1. Name of the Training: Aptitude

2. Name of the Trainer: Vijaya Raj

3. Students rating of Trainers :

S. No.	Date	Subject	Rating (√)			
			Excellent	Very good	Good	Average
1	22.6.17	Time and work			✓	

4. Two positive points about the programme:

Good Performance.

5. Suggestions for improvement:

Good.

Date: 22.6.17

Priyanka  
Signature

**K S R INSTITUTE FOR ENGINEERING AND TECHNOLOGY  
TIRUCHENGODE - 637 215**



**TRAINING PROGRAMME FEEDBACK FORM**

Name of the Student: B. Sweetha

Branch: CSE

Year / Sem: II / III

4. Name of the Training: Aptitude

5. Name of the Trainer: M.V. Jaya Raj

6. Students rating of Trainers :

S. No.	Date	Subject	Rating (√)			
			Excellent	Very good	Good	Average
1	22.6.17	Time & work		✓		

4. Two positive points about the programme:

Interesting,  
done useful.

5. Suggestions for improvement:

NP!

Date: 22.6.17

PRINCIPAL,  
K. S. R. INSTITUTE FOR  
ENGINEERING AND TECHNOLOGY,  
K. S. R. KALVINIACAR,  
TIRUCHENGODE - 637 215,  
NAMAKKAL DISTRICT, TAMIL NADU

B. Sweetha  
Signature

FN (312)

K S R INSTITUTE FOR ENGINEERING AND TECHNOLOGY  
TIRUCHENGODE - 637 215



TRAINING PROGRAMME FEEDBACK FORM

Name of the Student: S. Mounika Branch: B.Tech IT

Year / Sem: II / III

1. Name of the Training: Percentage (Appitude)

2. Name of the Trainer: Jaya Kumaravel

3. Students rating of Trainers: 4

S. No.	Date	Subject	Rating (√)			
			Excellent	Very good	Good	Average
1	22.6.17	APPS	✓			

4. Two positive points about the programme:  
Coaching is well.

5. Suggestions for improvement:  
Nil

Date: 22.6.17

J. M. P.  
Signature

K S R INSTITUTE FOR ENGINEERING AND TECHNOLOGY  
TIRUCHENGODE - 637 215



TRAINING PROGRAMME FEEDBACK FORM

Name of the Student: C. Priyanka Branch: E.C.E.

Year / Sem: II / III

4. Name of the Training: Appitude

5. Name of the Trainer: Jaya Kumaravel

6. Students rating of Trainers: 5

S. No.	Date	Subject	Rating (√)			
			Excellent	Very good	Good	Average
1	22.06.17	APPS	✓			

4. Two positive points about the programme:  
excellent coaching

5. Suggestions for improvement:  
Nil

Date: 22.6.17

PRINCIPAL,  
K. S. R. INSTITUTE FOR  
ENGINEERING AND TECHNOLOGY,  
K. S. R. KALVI NAGAR,  
TIRUCHENGODE - 637 215,  
NAMAKKAL DISTRICT, TAMIL NADU.

C. Priyanka  
Signature

TRAINING PROGRAMME FEEDBACK FORM



Name of the Student: A. Raja Rajan Branch: CSE

Year / Sem: II / III

1. Name of the Training : Placement training

2. Name of the Trainer : Nuguntharajan

3. Students rating of Trainers :

S. No.	Date	Subject	Rating (✓)			
			Excellent	Very good	Good	Average
1	22.06.17	SOFT SKILLS	✓			

4. Two positive points about the programme: \* Motivating ourself (motivated)  
\* develop in self confidence.

5. Suggestions for improvement: NIL

Date: 22.06.17

A. R. Pr...  
Signature

TRAINING PROGRAMME FEEDBACK FORM



Name of the Student: A. Raja Rajan Branch: CSE

Year / Sem: II / III

4. Name of the Training : placement training

5. Name of the Trainer : Kanakaraj

6. Students rating of Trainers :

S. No.	Date	Subject	Rating (✓)			
			Excellent	Very good	Good	Average
1	22.06.17	MODULE - II SOFT SKILLS			✓	

4. Two positive points about the programme: \* Interesting play, No boring  
\* Good refreshment

5. Suggestions for improvement:

Date: 22.06.17

PRINCIPAL,  
K. S. R. INSTITUTE FOR  
ENGINEERING AND TECHNOLOGY,  
K. S. R. KALVI NAGAR,  
TIRUCHENGODE - 637 215,  
NAMAKKAL Dt, TAMIL NADU.

A. R. Pr...  
Signature

AN

**K S R INSTITUTE FOR ENGINEERING AND TECHNOLOGY  
TIRUCHENGODE - 637 215**

**TRAINING PROGRAMME FEEDBACK FORM**



AN

Name of the Student: Preetha . E Branch: EEE

Year / Sem: II / III

1. Name of the Training : Basic Grammar and soft skills development

2. Name of the Trainer : Muhuntharajan . Mr.

3. Students rating of Trainers :

S. No.	Date	Subject	Rating (✓)			
			Excellent	Very good	Good	Average
1	22.06.2017	English			✓	

4. Two positive points about the programme:

✓ nice information  
✓ not getting bored

5. Suggestions for improvement:

nil

*[Signature]*  
Signature

Date:

**K S R INSTITUTE FOR ENGINEERING AND TECHNOLOGY  
TIRUCHENGODE - 637 215**

**TRAINING PROGRAMME FEEDBACK FORM**



AN

Name of the Student: PREETHA . E Branch: EEE

Year / Sem: II / III

4. Name of the Training : BASIC GRAMMAR and soft skills development

5. Name of the Trainer : Mr. Ganugaselvam

6. Students rating of Trainers :

S. No.	Date	Subject	Rating (✓)			
			Excellent	Very good	Good	Average
1	22.06.2017	English			✓	

4. Two positive points about the programme:

✓ not getting bored  
✓ done interesting puzzles

5. Suggestions for improvement:

nil

*[Signature]*  
Signature

Date: 22.06.2017

PRINCIPAL,  
K. S. R. INSTITUTE FOR  
ENGINEERING AND TECHNOLOGY,  
K. S. R. KALVI NAGAR,  
TIRUCHENGODE - 637 215,  
NAMAKKAL DI, TAMIL NADU.



Date: 22.06.17

Brindha M  
Signature

305 AN

KSR INSTITUTE FOR ENGINEERING AND TECHNOLOGY  
TIRUCHENGODE - 637 215  
TRAINING PROGRAMME FEEDBACK FORM



Name of the Student: N. Kasthika Branch: B.Tech CA (IT)

Year / Sem: VII / I<sup>st</sup>

4. Name of the Training: English

5. Name of the Trainer: Madhan

6. Students rating of Trainers :

S. No.	Date	Subject	Rating (✓)			
			Excellent	Very good	Good	Average
1	22.06.17 AN	English (Articles)		✓		

4. Two positive points about the programme:

- \* Easy to Understand
- \* Very useful.

5. Suggestions for improvement:

*(Handwritten mark)*

Date: 22.06.2017.

*(Handwritten signature)*

Signature

KSR INSTITUTE FOR  
 ENGINEERING AND TECHNOLOGY,  
 K. S. R. ALAY NAGAR,  
 TIRUCHENGODE - 637 215,  
 NARAYANGUDI, TAMIL NADU.

Date: 22.06.17

Brindha M  
Signature

K S R INSTITUTE FOR ENGINEERING AND TECHNOLOGY  
TIRUCHENGODE - 637 215  
TRAINING PROGRAMME FEEDBACK FORM



Name of the Student: M. Karthika Branch: B.Tech (IT)  
Year / Sem: II / II  
4. Name of the Training: English  
5. Name of the Trainer: Madhan  
6. Students rating of Trainers :

S. No.	Date	Subject	Rating (√)			
			Excellent	Very good	Good	Average
1	22.06.17 AN	English (Articles)		✓		

4. Two positive points about the programme:

- \* Easy to Understand
- \* Very useful.

5. Suggestions for improvement:

Date: 22.06.2017.

PRINCIPAL,  
K S R INSTITUTE FOR  
ENGINEERING AND TECHNOLOGY,  
K. S. R. KALVI NAGAR,  
TIRUCHENGODE - 637 215,  
NAMAKKAL DI, TAMIL NADU.

M. Karthika  
Signature

405 FN

K S R INSTITUTE FOR ENGINEERING AND TECHNOLOGY  
TIRUCHENGODE - 637 215

TRAINING PROGRAMME FEEDBACK FORM



Name of the Student: ANUSHA N Branch: CSE

Year / Sem: II / II

1. Name of the Training : ARTICLES, TENSE, HOMONYMS

2. Name of the Trainer : MADHAN S

3. Students rating of Trainers :

S. No.	Date	Subject	Rating (✓)			
			Excellent	Very good	Good	Average
1	22.6.2017	ENGLISH	✓			

4. Two positive points about the programme:

5. Suggestions for improvement:

Date: 22.6.2017

N. Anusha  
Signature

404 (AN)

K S R INSTITUTE FOR ENGINEERING AND TECHNOLOGY  
TIRUCHENGODE - 637 215

TRAINING PROGRAMME FEEDBACK FORM



Name of the Student: V. DIVYA DEVI - E. SUNITHA Branch: EEE

Year / Sem: 2017 / III

1. Name of the Training : Muthurajan English.

2. Name of the Trainer : Muthurajan.

3. Students rating of Trainers :

S. No.	Date	Subject	Rating (✓)			
			Excellent	Very good	Good	Average
1	22.6.17.	English	✓			

4. Two positive points about the programme:

1. Very improve my soft skills  
2. perfect

5. Suggestions for improvement:

NO

Date: 22.6.17.

PRINCIPAL,  
K. S. R. INSTITUTE FOR  
ENGINEERING AND TECHNOLOGY,  
K. S. R. KALU NAGAR,  
TIRUCHENGODE - 637 215  
NAMAKKAL DISTRICT

Signature

K S R INSTITUTE FOR ENGINEERING AND TECHNOLOGY  
TIRUCHENGODE - 637 215



TRAINING PROGRAMME FEEDBACK FORM

Name of the Student: S. Sugitha

Branch: B.Tech - IT

Year / Sem: II - 3

1. Name of the Training: Communication skills.

2. Name of the Trainer: Kanagaselvam

3. Students rating of Trainers :

S. No.	Date	Subject	Rating (✓)			
			Excellent	Very good	Good	Average
1	21.6.17	English Communication	✓			

4. Two positive points about the programme: Excellent trainer, Very useful to develop the communication skill

5. Suggestions for improvement: —

Date: 21.6.17

PRINCIPAL,  
K. S. R. INSTITUTE FOR  
ENGINEERING AND TECHNOLOGY,  
K. S. R. KALVI NAGAR,  
TIRUCHENGODE - 637 215,  
NAMAKKAL DI, TAMIL NADU.

S. Sugitha  
Signature

408 - 114

**K S R INSTITUTE FOR ENGINEERING AND TECHNOLOGY  
TIRUCHENGODE - 637 215**

**TRAINING PROGRAMME FEEDBACK FORM**



Name of the Student: M. KAVIYA

Branch: EEE

Year / Sem: II - III

1. Name of the Training : Placement

2. Name of the Trainer : Selvaraj

3. Students rating of Trainers :

S. No.	Date	Subject	Rating (√)			
			Excellent	Very good	Good	Average
1	22/6/17	Maths-Train Boats, Stream			✓	

4. Two positive points about the programme:

Summs are simple

5. Suggestions for improvement: Nothing

Date: 22/6/17

Maya  
Signature

**K S R INSTITUTE FOR ENGINEERING AND TECHNOLOGY  
TIRUCHENGODE - 637 215**

**TRAINING PROGRAMME FEEDBACK FORM**



Name of the Student: PRAKASH SP

Branch: EEE

Year / Sem: II, III

4. Name of the Training : PLACEMENT

5. Name of the Trainer : SELVARAJ

6. Students rating of Trainers :

S. No.	Date	Subject	Rating (√)			
			Excellent	Very good	Good	Average
1	22/6/17	MATHS, TRAIN BOATS, STREAM			✓	

4. Two positive points about the programme:

SIMPLE, SUM EASY

5. Suggestions for improvement:

NOTHING

Date: 22/6/17

PRINCIPAL,  
 K. S. R. INSTITUTE FOR  
 ENGINEERING AND TECHNOLOGY,  
 K. S. R. KALVI NAGAR,  
 TIRUCHENGODE - 637 215,  
 NAMAKKAL Dt, TAMIL NADU.

PRAKASH SP  
Signature

743

K S R INSTITUTE FOR ENGINEERING AND TECHNOLOGY  
TIRUCHENGODE - 637 215

TRAINING PROGRAMME FEEDBACK FORM



Name of the Student: KANIMOZHIS V

Branch: EEE

Year / Sem: II / III

1. Name of the Training: Types of sentences

2. Name of the Trainer: Viji

3. Students rating of Trainers :

S. No.	Date	Subject	Rating (√)			
			Excellent	Very good	Good	Average
1	22.6.17	English	✓			

4. Two positive points about the programme:

5. Suggestions for improvement:

Date: 22.6.17

  
Signature

K S R INSTITUTE FOR ENGINEERING AND TECHNOLOGY  
TIRUCHENGODE - 637 215

TRAINING PROGRAMME FEEDBACK FORM



Name of the Student: PRAVIN R

Branch: EEE

Year / Sem: II / III

4. Name of the Training: Types of sentences

5. Name of the Trainer: Viji

6. Students rating of Trainers :

S. No.	Date	Subject	Rating (√)			
			Excellent	Very good	Good	Average
1	22.6.17	English	✓			

4. Two positive points about the programme:

5. Suggestions for improvement:

Date: 22.6.17

  
K. S. R. INSTITUTE FOR  
ENGINEERING AND TECHNOLOGY,  
K. S. R. KALWALAKAR,  
TIRUCHENGODE - 637 215,  
NAMAKKAL Dt, TAMIL NADU.

  
Signature

K S R INSTITUTE FOR ENGINEERING AND TECHNOLOGY  
TIRUCHENGODE - 637 215

TRAINING PROGRAMME FEEDBACK FORM



413  
AN

Name of the Student: A.S. MALATHI

Branch: B.E-ECE-A

Year / Sem: II / II

1. Name of the Training : APTITUDE

2. Name of the Trainer : A. JEYAKUMAR

3. Students rating of Trainers :

S. No.	Date	Subject	Rating (✓)			
			Excellent	Very good	Good	Average
1	22.6.17	PROBABILITY	✓			

4. Two positive points about the programme: 1) NOT BORED  
2) INTERESTING.

5. Suggestions for improvement: -

A.S. Malathi  
Signature

Date: 22.6.17

K S R INSTITUTE FOR ENGINEERING AND TECHNOLOGY  
TIRUCHENGODE - 637 215

TRAINING PROGRAMME FEEDBACK FORM



413  
AN

Name of the Student: R. MONIKA

Branch: B.E-ECE-A

Year / Sem: II / II

4. Name of the Training : APTITUDE

5. Name of the Trainer : N. SURESH

6. Students rating of Trainers :

S. No.	Date	Subject	Rating (✓)			
			Excellent	Very good	Good	Average
1	22.6.17	TIME 2 WORK			✓	

4. Two positive points about the programme: NOT BORED

5. Suggestions for improvement:

PRINCIPAL,  
K. S. R. INSTITUTE FOR  
ENGINEERING AND TECHNOLOGY,  
K. S. R. MAIN NAGAR,  
TIRUCHENGODE - 637 215,  
NAMAKKAL DISTRICT, TAMIL NADU.  
R. Suresh  
Signature

Date: 22.6.17

K S R INSTITUTE FOR ENGINEERING AND TECHNOLOGY  
TIRUCHENGODE - 637 215

408-AN



TRAINING PROGRAMME FEEDBACK FORM

Name of the Student: G. Mani Bhavathi

Branch: B.Tech-IT

Year / Sem: II / II

1. Name of the Training: Probability

2. Name of the Trainer: Jaya kumar

3. Students rating of Trainers :

S. No.	Date	Subject	Rating (✓)			
			Excellent	Very good	Good	Average
1	22-6-17	Probability	✓			

4. Two positive points about the programme: learn many things

5. Suggestions for improvement: -

Date: 22-6-17

[Signature]  
Signature

K S R INSTITUTE FOR ENGINEERING AND TECHNOLOGY  
TIRUCHENGODE - 637 215



TRAINING PROGRAMME FEEDBACK FORM

Name of the Student: K. Nandan

Branch: ECE

Year / Sem: II years / 03

4. Name of the Training: probability

5. Name of the Trainer: Jayakumar

6. Students rating of Trainers :

S. No.	Date	Subject	Rating (✓)			
			Excellent	Very good	Good	Average
1	22.6.17	Probability			✓	

4. Two positive points about the programme: learn about probability

5. Suggestions for improvement: -

Date: 22.6.17

PRINCIPAL,  
K. S. R. INSTITUTE FOR  
ENGINEERING AND TECHNOLOGY,  
K. S. R. KALAI NAGAR,  
TIRUCHENGODE - 637 215,  
NAMAKKAL DL, TAMIL NADU.

[Signature]  
Signature



23/1/17 404 - AN

K S R INSTITUTE FOR ENGINEERING AND TECHNOLOGY  
TIRUCHENGODE - 637 215

TRAINING PROGRAMME FEEDBACK FORM



Name of the Student: Karthika Devi

Branch: EEE

Year / Sem: II / III

1. Name of the Training: Soft skills

2. Name of the Trainer: Mr. Mohan

3. Students rating of Trainers:

S. No.	Date	Subject	Rating (√)			
			Excellent	Very good	Good	Average
1	23.06.17	Grammar	✓			

4. Two positive points about the programme: Interactive session, cleared all doubts

5. Suggestions for improvement:

Date: 23.06.2017

Karthika  
Signature

K S R INSTITUTE FOR ENGINEERING AND TECHNOLOGY  
TIRUCHENGODE - 637 215

TRAINING PROGRAMME FEEDBACK FORM



Name of the Student: M. Karthika

Branch: B.Tech (IT)

Year / Sem: II / II

4. Name of the Training: English Accent

5. Name of the Trainer: Viji

6. Students rating of Trainers:

S. No.	Date	Subject	Rating (√)			
			Excellent	Very good	Good	Average
1	23.06.17	English (interaction)		✓		

4. Two positive points about the programme:

very use full  
Easy to understand

5. Suggestions for improvement:

Date: 23.06.17

M. Karthika  
Signature

1.08-FN

K S R INSTITUTE FOR ENGINEERING AND TECHNOLOGY  
TIRUCHENGODE - 637 215

TRAINING PROGRAMME FEEDBACK FORM



Name of the Student: G. Mani Bharathi

Branch: B.Tech-IT

Year / Sem: II / III

1. Name of the Training: Number system

2. Name of the Trainer: Sivakumar

3. Students rating of Trainers :

S. No.	Date	Subject	Rating (✓)			
			Excellent	Very good	Good	Average
1	23-6-17	Aptitude	✓			

4. Two positive points about the programme: lear more things and tricks.

5. Suggestions for improvement:

Date: 23-6-17

[Signature]  
Signature

K S R INSTITUTE FOR ENGINEERING AND TECHNOLOGY  
TIRUCHENGODE - 637 215

TRAINING PROGRAMME FEEDBACK FORM



Name of the Student: V. Aravindh

Branch: B.Tech/IT

Year / Sem: II / III

1. Name of the Training :

2. Name of the Trainer : Manakasevaran

3. Students rating of Trainers :

S. No.	Date	Subject	Rating (✓)			
			Excellent	Very good	Good	Average
1	23/6/17	English	✓			

4. Two positive points about the programme:

5. Suggestions for improvement:

Date: 23.6.17

[Signature]  
Signature

PRINCIPAL,  
K S R INSTITUTE FOR  
ENGINEERING AND TECHNOLOGY,  
K. S. R. KALMI NAGAR,  
TIRUCHENGODE - 637 215,  
NAMAKKAL Dt, TAMIL NADU.

K S R INSTITUTE FOR ENGINEERING AND TECHNOLOGY  
TIRUCHENGODE - 637 215

TRAINING PROGRAMME FEEDBACK FORM



413 FN

Name of the Student: A.S. MALATHI

Branch: B.E-ECE-A

Year / Sem: II/II

1.Name of the Training : APTITUDE

2.Name of the Trainer : N.SELVARAJ

3.Students rating of Trainers :

S. No.	Date	Subject	Rating (√)			
			Excellent	Very good	Good	Average
1	23.6.2017	STREAM AND BOATS			✓	

4. Two positive points about the programme: NOT BORED.

5. Suggestions for improvement:

Date: 23.6.2017

K S R INSTITUTE FOR ENGINEERING AND TECHNOLOGY,  
K. S. R. NADU, TIRUCHENGODE - 637 215,  
NAMANKAL Dt, TAMIL NADU.

A.S. Malathi  
Signature

K S R INSTITUTE FOR ENGINEERING AND TECHNOLOGY  
TIRUCHENGODE - 637 215

TRAINING PROGRAMME FEEDBACK FORM



Name of the Student: \_\_\_\_\_

Branch: \_\_\_\_\_

Year / Sem: \_\_\_\_\_

4.Name of the Training :

5.Name of the Trainer :

6.Students rating of Trainers :

S. No.	Date	Subject	Rating (√)			
			Excellent	Very good	Good	Average
1						

4. Two positive points about the programme:

5. Suggestions for improvement:

Date:

Signature

K S R INSTITUTE FOR ENGINEERING AND TECHNOLOGY  
TIRUCHENGODE - 637 215



TRAINING PROGRAMME FEEDBACK FORM

413 AN

Name of the Student: LOGESHVARAN

Branch: E.E.E.

Year / Sem: II / III

1. Name of the Training: PERCENTAGE

2. Name of the Trainer: KUMARAVEL

3. Students rating of Trainers: 3/5

S. No.	Date	Subject	Rating (√)			
			Excellent	Very good	Good	Average
1	23/6/17	MATHS			✓	

4. Two positive points about the programme: Nothing

5. Suggestions for improvement: Nothing

Date: 23/6/2017

*K. S. R. INSTITUTE FOR ENGINEERING AND TECHNOLOGY,  
K. S. R. KALIVAGAN,  
TIRUCHENGODE - 637 215,  
NAMAKKAL DI, TAMIL NADU.*  
Signature: [Signature]

K S R INSTITUTE FOR ENGINEERING AND TECHNOLOGY  
TIRUCHENGODE - 637 215



TRAINING PROGRAMME FEEDBACK FORM

Name of the Student: \_\_\_\_\_

Branch: \_\_\_\_\_

Year / Sem: \_\_\_\_\_

4. Name of the Training: \_\_\_\_\_

5. Name of the Trainer: \_\_\_\_\_

6. Students rating of Trainers: \_\_\_\_\_

S. No.	Date	Subject	Rating (√)			
			Excellent	Very good	Good	Average
1						

4. Two positive points about the programme: \_\_\_\_\_

5. Suggestions for improvement: \_\_\_\_\_

Date: \_\_\_\_\_

Signature \_\_\_\_\_



TRAINING PROGRAMME FEEDBACK FORM

FN 312

Name of the Student: P. Vignesh

Branch: ECE

Year / Sem: II<sup>nd</sup> Year / II<sup>nd</sup> Sem

1. Name of the Training: Time and block

2. Name of the Trainer: Mr. Suresh

3. Students rating of Trainers: 5/5

S. No.	Date	Subject	Rating (✓)			
			Excellent	Very good	Good	Average
1	23.06.17	Maths	✓			

4. Two positive points about the programme:

Useful class and calm Sir he didn't slept on his class.

5. Suggestions for improvement:

Nil.

P. Vignesh  
Signature

Date: 23.06.17.



TRAINING PROGRAMME FEEDBACK FORM

Name of the Student: V. Viji

Branch: IT

Year / Sem: II year / III sem

4. Name of the Training: Time and work

5. Name of the Trainer: Mr. Suresh

6. Students rating of Trainers: 5/5

S. No.	Date	Subject	Rating (✓)			
			Excellent	Very good	Good	Average
1	23.6.17	Maths	✓			

4. Two positive points about the programme:

nice teaching

5. Suggestions for improvement:

Nil.

Date: 23.6.2017

V. Viji  
Signature  
K. S. R. INSTITUTE FOR ENGINEERING AND TECHNOLOGY, TIRUCHENGODE - 637 215, NAMAKKAL

**K S R INSTITUTE FOR ENGINEERING AND TECHNOLOGY  
TIRUCHENGODE - 637 215**

**TRAINING PROGRAMME FEEDBACK FORM**



(Leor) AN

Name of the Student: R. SAM MCKENZIE

Branch: IT

Year / Sem: II / III

1. Name of the Training: Communication

2. Name of the Trainer: Mohan

3. Students rating of Trainers: 7/10

S. No.	Date	Subject	Rating (✓)			
			Excellent	Very good	Good	Average
1	23.6.17	Grammar		✓		

4. Two positive points about the programme: ~~NA~~

More facts  
Team work

5. Suggestions for improvement:

-

Date: 23.6.17

K S R INSTITUTE FOR  
ENGINEERING AND TECHNOLOGY,  
K. S. R. KALYANAGAR,  
TIRUCHENGODE - 637 215,  
NAMAKKAL DISTRICT, TAMIL NADU.

*[Signature]*  
Signature

**K S R INSTITUTE FOR ENGINEERING AND TECHNOLOGY  
TIRUCHENGODE - 637 215**

**TRAINING PROGRAMME FEEDBACK FORM**



(AOS) AN

Name of the Student: R. SAM MCKENZIE

Branch: IT

Year / Sem: II / III

4. Name of the Training: Communication

5. Name of the Trainer: Madhan

6. Students rating of Trainers: 8/10

S. No.	Date	Subject	Rating (✓)			
			Excellent	Very good	Good	Average
1	23.6.17	Grammar		✓		

4. Two positive points about the programme:

More facts  
Brief overview

5. Suggestions for improvement:

Could conduct few activities

Date: 23.6.17

*[Signature]*  
Signature

**K S R INSTITUTE FOR ENGINEERING AND TECHNOLOGY  
TIRUCHENGODE - 637 215**

**TRAINING PROGRAMME FEEDBACK FORM**



(A08)  
AN

Name of the Student: C. SWETHA

Branch: CSE

Year / Sem: II / II

1. Name of the Training : COMMUNICATION

2. Name of the Trainer : P. MOHAN

3. Students rating of Trainers :

S. No.	Date	Subject	Rating (√)			
			Excellent	Very good	Good	Average
1	23.06.17	ENGLISH		✓		

4. Two positive points about the programme:

- \* It was very useful to improve our communication skills.
- \* Improve our language.

5. Suggestions for improvement:

More activities should be needed for us.

Date: 23.06.17

C. Swetha  
Signature

**K S R INSTITUTE FOR ENGINEERING AND TECHNOLOGY  
TIRUCHENGODE - 637 215**

**TRAINING PROGRAMME FEEDBACK FORM**



(A08)  
AN

Name of the Student: C. SWETHA

Branch: CSE

Year / Sem: II / II

4. Name of the Training : COMMUNICATION

5. Name of the Trainer : S. MADHAN

6. Students rating of Trainers :

S. No.	Date	Subject	Rating (√)			
			Excellent	Very good	Good	Average
1	23.06.17	ENGLISH		✓	✓	

4. Two positive points about the programme:

- \* Improve our vocabulary skills.
- \* Searching for new words.

5. Suggestions for improvement:

Activities should be needed.

Date: 23.06.17

C. Swetha  
Signature

K S R INSTITUTE FOR  
ENGINEERING AND TECHNOLOGY,  
K. S. R. KALVI NAGAR,  
TIRUCHENGODE - 637 215,  
NAMAKKAL DISTRICT, TAMIL NADU.

**K S R INSTITUTE FOR ENGINEERING AND TECHNOLOGY  
TIRUCHENGODE - 637 215**

**TRAINING PROGRAMME FEEDBACK FORM**



Name of the Student: S. VENMATHI

Branch: CSE

Year / Sem: II / III

1. Name of the Training: Soft Skills

2. Name of the Trainer: MUKUNDH RAJ

3. Students rating of Trainers :

S. No.	Date	Subject	Rating (√)			
			Excellent	Very good	Good	Average
1	23.06.17	English	✓			

4. Two positive points about the programme:

5. Suggestions for improvement:

Date: 23.06.17

*S. Venmathi*  
Signature

**K S R INSTITUTE FOR ENGINEERING AND TECHNOLOGY  
TIRUCHENGODE - 637 215**

**TRAINING PROGRAMME FEEDBACK FORM**



Name of the Student: S. Swetha

Branch: IT

Year / Sem: II / III

4. Name of the Training: cross word and soft skills

5. Name of the Trainer: Mukundh Rajan

6. Students rating of Trainers :

S. No.	Date	Subject	Rating (√)			
			Excellent	Very good	Good	Average
1	23/6/17	English	✓			

4. Two positive points about the programme:

5. Suggestions for improvement:

Date: 23.06.17

**PRINCIPAL,**  
**K. S. R. INSTITUTE FOR**  
**ENGINEERING AND TECHNOLOGY,**  
**K. S. R. KALU NAGAR,**  
**TIRUCHENGODE - 637 215,**  
**NAMAKKAL DISTRICT, TAMIL NADU**

Signature



K S R INSTITUTE FOR ENGINEERING AND TECHNOLOGY  
TIRUCHENGODE - 637 215



TRAINING PROGRAMME FEEDBACK FORM

Name of the Student: S. MERLIN

Branch: EEE

Year / Sem: II / III

1. Name of the Training: Placement Training

2. Name of the Trainer: Vijayaraj.

3. Students rating of Trainers :

S. No.	Date	Subject	Rating (✓)			
			Excellent	Very good	Good	Average
1	23.6.17	Work & time	✓			✗

4. Two positive points about the programme:

\* Easily understand.

5. Suggestions for improvement:

\* /

Date: 23.6.17

Signature

K S R INSTITUTE FOR ENGINEERING AND TECHNOLOGY  
TIRUCHENGODE - 637 215



TRAINING PROGRAMME FEEDBACK FORM

Name of the Student: J. Stephen Raj

Branch: IT

Year / Sem: II / III

4. Name of the Training: Placement Training

5. Name of the Trainer: Vijayaraj sir

6. Students rating of Trainers :

S. No.	Date	Subject	Rating (✓)			
			Excellent	Very good	Good	Average
1	23.6.17	Work & Time	✓			✓

4. Two positive points about the programme:

\* Easy to understand all topics

5. Suggestions for improvement:

Date: 23/6/2017

PRINCIPAL,  
K. S. R. INSTITUTE FOR  
ENGINEERING AND TECHNOLOGY,  
K. S. R. KALVI NAGAR,  
TIRUCHENGODE - 637 215,  
NAMAKKAL DISTRICT, TAMIL NADU.

Signature

K S R INSTITUTE FOR ENGINEERING AND TECHNOLOGY  
TIRUCHENGODE - 637 215

TRAINING PROGRAMME FEEDBACK FORM



Name of the Student: D. Gnanapriya

Branch: IT

Year / Sem:

1. Name of the Training : English

2. Name of the Trainer : Mukundan

3. Students rating of Trainers :

S. No.	Date	Subject	Rating (√)			
			Excellent	Very good	Good	Average
1	23/6/17	English	✓			

4. Two positive points about the programme:

Nothing

5. Suggestions for improvement:

Date:

  
Signature

K S R INSTITUTE FOR ENGINEERING AND TECHNOLOGY  
TIRUCHENGODE - 637 215

TRAINING PROGRAMME FEEDBACK FORM



Name of the Student: M. Kamesh  
D. Gnanapriya

Branch: CSE

Year / Sem: II

4. Name of the Training : English

5. Name of the Trainer : Mukundan

6. Students rating of Trainers :

S. No.	Date	Subject	Rating (√)			
			Excellent	Very good	Good	Average
1	23/6/17	English		✓		

4. Two positive points about the programme:

5. Suggestions for improvement:

Date:

  
PRINCIPAL,  
K. S. R. INSTITUTE FOR  
ENGINEERING AND TECHNOLOGY,  
K. S. R. KALVI NAGAR,  
TIRUCHENGODE - 637 215,  
NAMAKKAL DISTRICT, TAMIL NADU.

  
Signature

**K S R INSTITUTE FOR ENGINEERING AND TECHNOLOGY  
TIRUCHENGODE – 637 215**



**TRAINING PROGRAMME FEEDBACK FORM**

Name of the Student: S. Yogesh Branch: FCP

Year / Sem: 2<sup>nd</sup> / 3<sup>rd</sup> Sem

1. Name of the Training: Boats and Stream

2. Name of the Trainer: Selvaraj

3. Students rating of Trainers: 5.★

S. No.	Date	Subject	Rating (✓)			
			Excellent	Very good	Good	Average
1	24.6.17		✓			

4. Two positive points about the programme: good understanding

5. Suggestions for improvement: \_\_\_\_\_

PRINCIPAL,  
K. S. R. INSTITUTE FOR  
ENGINEERING AND TECHNOLOGY,  
K. S. R. KALM NAGAR,  
TIRUCHENGODE - 637 215,  
NAMAKKAL DT, TAMIL NADU.

S. Yogesh  
Signature

Date: \_\_\_\_\_

**K S R INSTITUTE FOR ENGINEERING AND TECHNOLOGY  
TIRUCHENGODE – 637 215**



**TRAINING PROGRAMME FEEDBACK FORM**

Name of the Student: \_\_\_\_\_ Branch: \_\_\_\_\_

Year / Sem: \_\_\_\_\_

4. Name of the Training: \_\_\_\_\_

5. Name of the Trainer: \_\_\_\_\_

6. Students rating of Trainers: \_\_\_\_\_

S. No.	Date	Subject	Rating (✓)			
			Excellent	Very good	Good	Average
1						

4. Two positive points about the programme: \_\_\_\_\_

5. Suggestions for improvement: \_\_\_\_\_

Date: \_\_\_\_\_

Signature \_\_\_\_\_

FN(312)

K S R INSTITUTE FOR ENGINEERING AND TECHNOLOGY  
TIRUCHENGODE - 637 215



TRAINING PROGRAMME FEEDBACK FORM

Name of the Student: S. Mounika

Branch: B.Tech-IT

Year / Sem: 2<sup>nd</sup> / 3

1.Name of the Training : Jayakumar - Probability

2.Name of the Trainer : Jayakumar

3.Students rating of Trainers :

S. No.	Date	Subject	Rating (√)			
			Excellent	Very good	Good	Average
1	24/06/17	probability	✓			

4. Two positive points about the programme:

Good Teaching

5. Suggestions for improvement:

Nil

Date: 24/06/17

  
 PRINCIPAL,  
 K. S. R. INSTITUTE FOR  
 ENGINEERING AND TECHNOLOGY,  
 K. S. R. KALVI NAGAR,  
 TIRUCHENGODE - 637 215,  
 NAMAKKAL DISTRICT, TAMIL NADU.

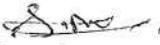
  
 Signature

K S R INSTITUTE FOR ENGINEERING AND TECHNOLOGY  
TIRUCHENGODE - 637 215

405 FN

TRAINING PROGRAMME FEEDBACK FORM



Name of the Student: Gowri.S

Branch: CSE

Year / Sem: II / III

1.Name of the Training : Mohan

2.Name of the Trainer :

3.Students rating of Trainers :

S. No.	Date	Subject	Rating (√)			
			Excellent	Very good	Good	Average
1	24.06.17	English	✓			

4. Two positive points about the programme:

Good teaching

5. Suggestions for improvement:

Date: 24.06.2017

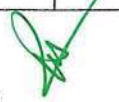
  
 PRINCIPAL,  
 K. S. R. INSTITUTE FOR  
 ENGINEERING AND TECHNOLOGY,  
 K. S. R. KALVI NAGAR,  
 TIRUCHENGODE - 637 215,  
 NAMAKKAL DISTRICT, TAMIL NADU.

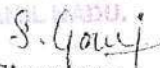
  
 Signature

K S R INSTITUTE FOR ENGINEERING AND TECHNOLOGY  
TIRUCHENGODE - 637 215

TRAINING PROGRAMME FEEDBACK FORM



403 FN

Name of the Student: R. YUVAPRIYA

Branch: IT

Year / Sem: II / III

1. Name of the Training : COMMUNICATION

2. Name of the Trainer : T.VJI

3. Students rating of Trainers :

S. No.	Date	Subject	Rating (✓)			
			Excellent	Very good	Good	Average
1	24/06/17	ENGLISH		✓		

4. Two positive points about the programme:

1. We improve our discipline knowledge.
2. We learn how to response and greeting others.

5. Suggestions for improvement:

Activities needed.

Date: 24/06/17

R. Yuvapriya  
Signature

K S R INSTITUTE FOR ENGINEERING AND TECHNOLOGY  
TIRUCHENGODE - 637 215

TRAINING PROGRAMME FEEDBACK FORM



Name of the Student: R. YUVAPRIYA

Branch: IT

Year / Sem: II / III

4. Name of the Training : COMMUNICATION

5. Name of the Trainer : T.VJI

6. Students rating of Trainers :

S. No.	Date	Subject	Rating (✓)			
			Excellent	Very good	Good	Average
1	24/06/17	ENGLISH		✓		

4. Two positive points about the programme:

Same improvement.

5. Suggestions for improvement:

Activities needed.

Date: 24/06/17

PRINCIPAL  
K S R INSTITUTE FOR  
ENGINEERING AND TECHNOLOGY,  
K. S. R. KALIA NAGAR,  
TIRUCHENGODE - 637 215,  
NARAKKAL DE TAMIL NADU.

R. Yuvapriya  
Signature

(403) FN

**K S R INSTITUTE FOR ENGINEERING AND TECHNOLOGY  
TIRUCHENGODE - 637 215**



**TRAINING PROGRAMME FEEDBACK FORM**

Name of the Student: R. RAM NERFALYR

Branch: IT

Year / Sem: II / II

1. Name of the Training: Viji Communication

2. Name of the Trainer: Viji

3. Students rating of Trainers: 8/10

S. No.	Date	Subject	Rating (✓)			
			Excellent	Very good	Good	Average
1	24.6.19	Communication		✓		

4. Two positive points about the programme:

More facts  
Wide knowledge

5. Suggestions for improvement:

Date: 24.6.19

Signature

**K S R INSTITUTE FOR ENGINEERING AND TECHNOLOGY  
TIRUCHENGODE - 637 215**



**TRAINING PROGRAMME FEEDBACK FORM**

Name of the Student: R. RAM NERFALYR

Branch: IT

Year / Sem: II / II

4. Name of the Training: Viji Communication

5. Name of the Trainer: Viji

6. Students rating of Trainers: 8/10

S. No.	Date	Subject	Rating (✓)			
			Excellent	Very good	Good	Average
1	24.6.19	Communication		✓		

4. Two positive points about the programme:

More facts  
Wide knowledge

5. Suggestions for improvement:

Date: 24.6.19

**PRINCIPAL,**  
**K. S. R. INSTITUTE FOR**  
**ENGINEERING AND TECHNOLOGY,**  
**K. S. F. KANTHAGAR,**  
**TIRUCHENGODE - 637 215,**  
**NAMANGAL DISTRICT, TAMIL NADU.**

Signature

K S R INSTITUTE FOR ENGINEERING AND TECHNOLOGY  
TIRUCHENGODE - 637 215

TRAINING PROGRAMME FEEDBACK FORM



408 - FN

Name of the Student: S. Sugitha

Branch: Information Technology

Year / Sem: II

1. Name of the Training : Percentage.

2. Name of the Trainer : N. Kumaravel

3. Students rating of Trainers :

S. No.	Date	Subject	Rating (✓)			
			Excellent	Very good	Good	Average
1	24.6.17	Percentage	✓			

4. Two positive points about the programme: Learn many things about percentage.

5. Suggestions for improvement: -

Date: 24.6.17.

S. Sugitha  
Signature

K S R INSTITUTE FOR ENGINEERING AND TECHNOLOGY  
TIRUCHENGODE - 637 215

TRAINING PROGRAMME FEEDBACK FORM



Name of the Student: Prakash SP

Branch: EEE

Year / Sem: II, III

4. Name of the Training : PERCENTAGE

5. Name of the Trainer : N. KUMARAVEL

6. Students rating of Trainers :

S. No.	Date	Subject	Rating (✓)			
			Excellent	Very good	Good	Average
1	24.6.17	PERCENTAGE			✓	

4. Two positive points about the programme:

EASY TO UNDERSTAND

5. Suggestions for improvement: -

Date: 24.06.17

Prakash SP  
Signature

K. S. R. INSTITUTE FOR  
ENGINEERING AND TECHNOLOGY,  
K. S. R. ROAD, JAY,  
TIRUCHENGODE - 637 215  
NAMAKKA PRAKASH SP

K S R INSTITUTE FOR ENGINEERING AND TECHNOLOGY  
TIRUCHENGODE - 637 215

TRAINING PROGRAMME FEEDBACK FORM



Name of the Student: S. Sibir

Branch: EEE

Year / Sem: I / III

1. Name of the Training: S. MADHAN Articles, Tenses, Homonyms

2. Name of the Trainer: S. MADHAN

3. Students rating of Trainers :

S. No.	Date	Subject	Rating (✓)			
			Excellent	Very good	Good	Average
1	24.6.17	ENGLISH		✓		

4. Two positive points about the programme:

1. It is easy to learn tenses.

2. Knows the meaning of homonyms.

5. Suggestions for improvement:

- Nil -

S. Sibir  
Signature

Date: 24.6.17

K S R INSTITUTE FOR ENGINEERING AND TECHNOLOGY  
TIRUCHENGODE - 637 215

TRAINING PROGRAMME FEEDBACK FORM



Name of the Student: N. Syad Selman

Branch: ECE

Year / Sem: I / III

4. Name of the Training: Tenses, Homonyms

5. Name of the Trainer: S. Madhan

6. Students rating of Trainers :

S. No.	Date	Subject	Rating (✓)			
			Excellent	Very good	Good	Average
1	24.6.17	English		✓		

4. Two positive points about the programme:

1. easy to learn

2. Knows the uses of articles

5. Suggestions for improvement:

- Nil -

Date: 24.6.17

S. Madhan  
Signature

Signature



K S R INSTITUTE FOR ENGINEERING AND TECHNOLOGY  
TIRUCHENGODE - 637 215

TRAINING PROGRAMME FEEDBACK FORM



Name of the Student: S. BHAVYASHREE

Branch: ECE

Year / Sem: II<sup>nd</sup> - III

1. Name of the Training: JAYAKUMAR.

2. Name of the Trainer: Probability

3. Students rating of Trainers: Good.

S. No.	Date	Subject	Rating (✓)			
			Excellent	Very good	Good	Average
1					✓	

4. Two positive points about the programme: (i) Easy to understand.  
(ii) Very clear.

5. Suggestions for improvement: —

Date:

Signature

409 (FN)

K S R INSTITUTE FOR ENGINEERING AND TECHNOLOGY  
TIRUCHENGODE - 637 215

TRAINING PROGRAMME FEEDBACK FORM



Name of the Student: S. Yogesh

Branch: ECE

Year / Sem: II 2<sup>nd</sup> sem

4. Name of the Training: JAYAKUMAR

5. Name of the Trainer: probability

6. Students rating of Trainers: good.

S. No.	Date	Subject	Rating (✓)			
			Excellent	Very good	Good	Average
1			✓			

4. Two positive points about the programme: Extraordinary

5. Suggestions for improvement: —

Date:

Signature

PRINCIPAL,  
K. S. R. INSTITUTE FOR  
ENGINEERING AND TECHNOLOGY,  
K. S. R. KALVI NAGAR,  
TIRUCHENGODE - 637 215,  
NAMAKKAL Dt, TAMIL NADU.

K S R INSTITUTE FOR ENGINEERING AND TECHNOLOGY  
TIRUCHENGODE - 637 215

TRAINING PROGRAMME FEEDBACK FORM



413 AN

Name of the Student: MEKALAI . K

Branch: ECE - A

Year / Sem: II / 3<sup>rd</sup>

1. Name of the Training : APTITUDE

2. Name of the Trainer : PD

3. Students rating of Trainers :

S. No.	Date	Subject	Rating (√)			
			Excellent	Very good	Good	Average
1	24.6.17	APTITUDE Numer System			✓	

4. Two positive points about the programme: i) It's easy to remember basics,  
ii) Shortcuts and logics are taught -

5. Suggestions for improvement:

nothing

Date: 24.6.17

  
Signature

K S R INSTITUTE FOR ENGINEERING AND TECHNOLOGY  
TIRUCHENGODE - 637 215

TRAINING PROGRAMME FEEDBACK FORM



413 AN

Name of the Student: G. Dharmarajini

Branch: ECE - A

Year / Sem: II / 3<sup>rd</sup>

4. Name of the Training : APTITUDE

5. Name of the Trainer : PD

6. Students rating of Trainers :

S. No.	Date	Subject	Rating (√)			
			Excellent	Very good	Good	Average
1	24.6.17	Apptitude revision			✓	

4. Two positive points about the programme: i) Revision is good

ii) Not bored.

5. Suggestions for improvement: -

Date: 24.6.17

  
PRINCIPAL  
K. S. R. INSTITUTE FOR  
ENGINEERING AND TECHNOLOGY,  
K. S. R. KALVI NAGAR,  
TIRUCHENGODE - 637 215,  
NARAYANAPURAM, TAMIL NADU.

Signature

# ***2. LANGUAGE AND COMMUNICATION SKILLS***

**K S R INSTITUTE FOR ENGINEERING AND TECHNOLOGY**

**LANGUAGE AND COMMUNICATION SKILLS CONSOLIDATED LIST**

**Academic Year:2017-2018**

<b>S.NO.</b>	<b>Name of the capability enhancement program</b>	<b>Date of implementation (DD-MM-YYYY)</b>	<b>Number of students enrolled</b>	<b>Name of the agencies/consultants involved with contact details (if any)</b>
1	Essay Writing	09.09.2017	51	KSRIET-Linga Club, hod_english@ksriet.ac.in
2	Slogan Writing	13.10.2017	42	KSRIET-Linga Club, hod_english@ksriet.ac.in
3	Poem Composing	13.10.2017	23	KSRIET-Linga Club, hod_english@ksriet.ac.in
4	JAM-Just a Minute	03.02.2018	29	KSRIET-Linga Club, hod_english@ksriet.ac.in
5	Spell Bee	03.02.2018	22	KSRIET-Linga Club, hod_english@ksriet.ac.in
6	Tongue Twister	03.02.2018	30	KSRIET-Linga Club, hod_english@ksriet.ac.in

**PRINCIPAL**

**PRINCIPAL,  
K. S. R. INSTITUTE FOR  
ENGINEERING AND TECHNOLOGY,  
K. S. R. KALVI NAGAR,  
TIRUCHENGODE - 637 216,  
NAMAKKAL Dt, TAMIL NADU.**

**K S R INSTITUTE FOR ENGINEERING AND TECHNOLOGY  
TIRUCHENGODE - 637 215**

REF: KSRIET/ENG/E-CIR/2017-2018/001

DATE: 06.09.2017

**CIRCULAR**

This is to inform all the students that **Lingua Club (A Lantern to Quest...)** has planned to conduct Essay Writing competition on 09<sup>th</sup> September 2017. Interested students can enroll their names with Mr. P. Mohan , Assistant Professor of English on or before 08.09.2017. The details of the competition are as follows.

Topic: Need of NEET?

Duration: 30 Minutes

Venue: Language Lab

Date: 09.09.2017

Time: 9:15 a.m.

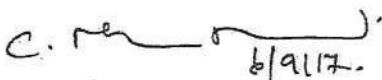
  
6/9/17.  
**Dr. C. Muguntharajan**  
Convenor - Lingua Club

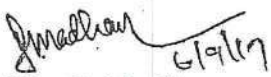
  
6/9/17  
**Mr. S. Madhan**  
Organiser - Lingua Club

  
**PRINCIPAL**

**Circulated to:**

1. HODs - All Departments
2. College Notice Board
3. All I, II, III and IV Year Classes

  
**PRINCIPAL,**  
**K. S. R. INSTITUTE FOR**  
**ENGINEERING AND TECHNOLOGY,**  
**K. S. R. KALVI NAGAR,**  
**TIRUCHENGODE - 637 215,**  
**NAMAKKAL Dt, TAMIL NADU.**

# K S R INSTITUTE FOR ENGINEERING AND TECHNOLOGY

## DEPARTMENT OF ENGLISH

### LINGUA CLUB

#### ESSAY WRITING

#### REGISTRATION FORM

Date: 09.09.2017



S. No.	Name	Class	Signature
1	HARIHARAN.P	I-Mech	Harisharan P
2	Gondhale . R	I-Mech	Cm
3	CHANDRU . M	I-Mech	Chandra.M
4	PRASANTH . R	I-Mech	Prasant R
5	Prahalad . J	I-Mech	Prahalad
6	Abinaya . S	I-CSE	Abinaya S
7	BOBU . R	I-CSE	Bobu R
8	BOOPALAN . V	I-CSE	Boopalana . V
9	Guna . M	I-CSE	Guna . M
10	Kishore P	I-CSE	Kishore . P
11	Monoranjith . M	I-CSE	Monoranjith . M
12	Kesavan . S	I-CSE	Kesavan S
13	SRIRAMA . S	I-IT	Srirama . S
14	Vimalraj . G	I-IT	Vimalraj . G
15	SHIVANI . N	I-IT	Shivani . N
16	ASHA	I-EEE	Asha . .
17	Balaji . S	I-EEE	Balaji . S
18	Hari SR	I-EEE	Hari . SR
19	Kanya A	I-EEE	Kanya . A
20	Supriya K	I-EEE	K . Supriya
21	Manjula R	I-ECE	Manjula . R
22	Janarth . S	I-ECE	Janarth . S
23	Sharmathi . S	I-ECE	Sharmathi . S
24	Shanthosh . K	I-ECE	Shanthosh . K
25	Govind . D	I-IT	Govind . D
26	Sandhya . G	I-IT	Sandhya . G
27	Dhanish . V	I-ECE	Dhanish . V
28	Hemalatha . S	I-ECE	Hemalatha . S
29	Muthulakshmi . S	I-ECE	Muthulakshmi . S
30	Booma . V	I-ECE	Booma . V
31	Thiyagu . M	I-ECE	Thiyagu . M
32	Rajivama Chandran	I-ECE	Rajivama . Chandran
33	Prasitha . S	I-IT	Prasitha . S
34	Sarav . V	I-IT	Sarav . V
35	Vimalraj . Y	I-IT	Vimalraj . Y
36	ashok kumar	I-IT	ashok . kumar

PRINCIPAL,  
K. S. R. INSTITUTE FOR  
ENGINEERING AND TECHNOLOGY,  
K. S. R. KALVI NAGAR,



**K S R INSTITUTE FOR ENGINEERING AND TECHNOLOGY**

**TIRUCHENGODE - 637 215**

**KSRIET/ENG/CIR/2017-2018/007**

**DATE: 11.10.2017**

**CIRCULAR**

This is to inform all the students that **Lingua Club (A Lantern to Quest...)** has planned to conduct Slogan Writing and Poem Composing competitions on 13<sup>th</sup> October 2017. Interested students can enroll their names with Mr. S. Madhan, Assistant Professor of English on or before 12.10.2017. The details of the competitions are as follows.

Topic: On the Spot

Duration: 30 Minutes for each competition

Venue: Language Lab

Date: 13.10.2017

Time: 01:15 p.m.

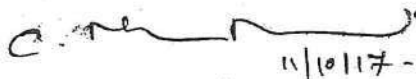
  
11/10/17

**Dr. C. Muguntharajan**  
Convenor - Lingua Club

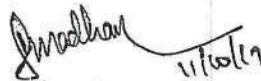
  
11/10/17

**Mr. S. Madhan**  
Organiser - Lingua Club

  
11/10/17

**PRINCIPAL**

**Circulated to:**

1. HoDs - All Departments
2. College Notice Board
3. All I, II, III and IV Year Classes

  
**PRINCIPAL,**  
**K. S. R. INSTITUTE FOR**  
**ENGINEERING AND TECHNOLOGY,**  
**K. S. R. KALVI NAGAR,**  
**TIRUCHENGODE - 637 215,**  
**NAMAKKAL DISTRICT, TAMIL NADU.**



# K S R INSTITUTE FOR ENGINEERING AND TECHNOLOGY

## DEPARTMENT OF ENGLISH

### LINGUA CLUB

## *Slogan Writing*

### REGISTRATION FORM

Date: 13.10.2017



AI

S. No	Name	Class	Signature
1	Logesh . R	I-Mech	Logesh . R
2	Mandj . N	S-Mech	Mandj . N
3	PRAADHAR . R	S-Mech	Pradhar . R
4	Kaun . M	S-Mech	Kaun . M
5	Karthik . A . S	E-Mech	Karthik . A . S
6	Dharshini . P	I-CSE	Dharshini . P
7	Dhargh Kumar	I-CSE	Dhargh Kumar
8	Zango . M	I-CSE	Zango . M
9	Kishor . P	I-CSE	Kishor . P
10	Marimuthu . R	I-CSE	Marimuthu . R
11	Bhagyashree . H	I-CSE	Bhagyashree . H
12	Jessica Collins . J . P	C-IT	Jessica Collins . J . P
13	RAGHU . C	S-IT	Raghu . C
14	SARAN . V	S-IT	Saran . V
15	SURYA P	I-EEE	Surya P
16	Silambarasan	I-EEE	Silambarasan
17	Selvam B	I-EEE	Selvam . B
18	Sujith . S	I-EEE	Sujith . S
19	Vaibhava . S	I-EEE	Vaibhava . S
20	Mangikumar S	I-EEE	Mangikumar S
21	Suryapriya . K	I-ECE/B	Suryapriya . K
22	Jessica Collins . J . P	I-IT	Jessica
23	Ramya . S	I-EEE	Ramya . S
24	Gobalraj B	I-Mech	Gobalraj . B
25	Hari ram B	I-Mech	Hari Ram . B
26	Boopathi . S	I-Mech	Boopathi . S
27	BALAJI . S	I-Mech	Balaji . S
28	ARAVINDH . S . R	I-Mech	S . R . Aravindh
29	Kathivel . M	I-Mech	M . Kathivel
30	C Mohanraj	I-Mech	C . Mohanraj
31	Prabu . J	I-Mech	J . Prabu
32	Narayan kumar G	I-EEE	Narayan
33	Vimalraj . G	I-EEE	Vimalraj . G
34	Manohari . S	I-IT	Manohari . S
35	Jessica Danil . R	I-IT	Jessica . R
36	Saran V	I-IT	Saran

S. No	Name	Class	Signature
37	Thiyagu. M	I - ECE	M. Thiyagu
38	Sinduja. k	I - ECE	Sinduja
39	Ganivasan. A	I - ECE	Ganivasan
40	Anilazhagan.	I - ECE	Anilazhagan
41	Santhosh. k	I - ECE	Santhosh
42	Pavithiran. S	I - CSE	Pavithiran
		P. Mohan	(P. MOHAN)
			7316154
			AP / English



**K S R INSTITUTE FOR ENGINEERING AND TECHNOLOGY  
TIRUCHENGODE - 637 215**

**KSRIET/ENG/CIR/2017-2018/010**

**DATE: 30.01.2018**

**CIRCULAR**

This is to inform all the students that **Lingua Club (A Lantern to Quest...)** has planned to conduct JAM, Spell Bee and Tongue Twister competitions on 03<sup>rd</sup> February 2018. Interested students can enroll their names with Mr. S. Madhan, Assistant Professor of English on or before 01.02.2018. The details of the competitions are as follows.

**Topic: On the Spot**

**Duration: 30 Minutes for each competition**

**Venue: Language Lab**

**Date: 03.02.2018**

**Time: 09:00 a.m.**

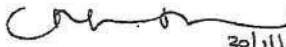
  
30/1/18  
**Dr. C. Muguntharajan**  
Convenor - Lingua Club

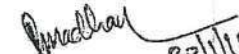
  
30/1/18  
**Mr. S. Madhan**  
Organiser - Lingua Club

  
30/1/18  
**PRINCIPAL**

**Circulated to:**

- 1. HoDs - All Departments**
- 2. College Notice Board**
- 3. All I, II, III and IV Year Classes**

  
**PRINCIPAL,**  
**K. S. R. INSTITUTE FOR**  
**ENGINEERING AND TECHNOLOGY,**  
**K. S. R. KALVI NAGAR,**  
**TIRUCHENGODE - 637 215,**  
**NAMAKKAL Dt, TAMIL NADU.**



# K S R INSTITUTE FOR ENGINEERING AND TECHNOLOGY

DEPARTMENT OF ENGLISH

LINGUA CLUB

SPELL BEE

REGISTRATION FORM

Date: 03.02.2018



22

S. No	Name	Class	Signature
1	Ajith . R	1-Mech	Ajith
2	Hairam . B	1-Mech-A	Hairam
3	Ashwin . M	1-Mech	Ashwin M
4	KISHOR . U	1-ECE	Kishor
5	HANJULA T	1-ECE	Hanjula
6	Mounish . G	2-IT	Mounish G
7	Kannan . P	1-IT	Kannan P
8	ALBA . P	1-ECE	Alba P
9	RANYA . P	1-EEE	Ranya
10	SARAN . V	1-IT	Saran V
11	Deepak Kumar	1-CSE	Deepak Kumar
12	ELANJO M	1-CSE	Elango M
13	harikaran . S	1-CSE	harikaran S
14	SINDUJA . S	1-ECE	Sinduja
15	HARISHOM B	1-NEEM	Harishom
16	DINNEESH P	1-ECE	Dinneesh P
17	Aarsha . R	1-EEE	Aarsha R
18	Romya . A	1-EEE	Romya A
19	Arul . M	1-EEE	Arul M
20	Jeevitha . P	1-EEE	Jeevitha P
21	Romya . P	1-EEE	Romya P
22	SELVAM . B	1-EEE	Selva B
			P. Mollan 3/2/18
			(P. Mollan)
			A. B. R.

PRINCIPAL,  
K. S. R. INSTITUTE FOR  
ENGINEERING AND TECHNOLOGY,  
K. S. R. (CALVI) ROAD,  
TIRUCHENGAI - 621 115,  
NANDYAL DI, TAMIL NADU.

# K S R INSTITUTE FOR ENGINEERING AND TECHNOLOGY

DEPARTMENT OF ENGLISH

LINGUA CLUB

TONGUE TWISTER

REGISTRATION FORM

Date: 03.02.2018



31

S. No	Name	Class	Signature
1	PRAVEEN KUMAR	S-Mech	Praveen Kumar
2	D Prasad . S	S-MECH	D Prasad . S
3	Deepak . K	SMECH	Deepak . K
4	ARUNESH . J	S-Mech	Arunesh . J
5	KISHORE . D	I-EEF	Kishore . D
6	Jayanth S	I-EEF	Jayanth S
7	dinesh . U.G	I-EEF	Dinesh . U.G
8	JAWAHAR RAJA P	I-EEF	Jawahar Raja . P
9	BUTITH . S	I-EEF	Butith . S
10	Gobika . M	S-IT	Gobika . M
11	VINOTHINI . R	S-IT	Vinodhini . R
12	Ashok Kumar . S	S-IT	Ashok Kumar . S
13	Dinmesh P	I-EEF	Dinmesh P
14	Mangy Ranjith . M	I-CSE	Mangy Ranjith . M
15	MARI MUTHU . R	I-CSE	Mari Muthu . R
16	Kolavan S	I-CSE	Kolavan S
17	Suryapriya . K	I-EEF	Suryapriya . K
18	STINDITA . K	I-EEF	Stindita . K
19	Ganesh . M	I-IT	Ganesh . M
20	ANVA . P	I-CSE	Anva . P
21	SURYA . P	I-EEF	Surya . P
22	PRASATH . S	I-EEF	Prasath . S
23	ALKA . P	I-EEF	Alka . P
24	Kishor . M	I-EEF	Kishor . M
25	Prasath . S	I-EEF	Prasath . S
26	Suresh . P	I-EEF	Suresh . P
27	MANJULA . T	I-EEF	Manjula . T
28	Sakthivel . P	I-EEF	Sakthivel . P
29	Booma . V	I-EEF	Booma . V
30	Shamini . S	I-EEF	Shamini . S
(31)			
32			
33	PRINCIPAL,		
34	K. S. R. INSTITUTE FOR		
35	ENGINEERING AND TECHNOLOGY,		

K. S. R. MALVI NAGAR,  
TIRUCHENGODE - 617 215,  
NAMAKAL DI, TAMIL NADU.

# ***3. LIFE SKILLS***

***(Yoga, physical  
fitness, health and  
hygiene)***



**K S R INSTITUTE FOR ENGINEERING AND TECHNOLOGY**  
**LIFE SKILLS (YOGA, PHYSICAL FITNESS, HEALTH AND HYGIENE)**  
**CONSOLIDATED LIST**

**Academic Year:2017-2018**

<b>S.NO.</b>	<b>Name of the capability enhancement program</b>	<b>Date of implementation (DD-MM-YYYY)</b>	<b>Number of students enrolled</b>	<b>Name of the agencies/consultants involved with contact details (if any)</b>
1	Yoga for Faculties	30.06.2017	62	KSRIET-NSS,nssksriet@gmail.com
2	Blood Donation Drive	12.07.2017	62	KSRIET-NSS,nssksriet@gmail.com
3	An Essay Competition on AIDS Awareness	01.12.2017	26	KSRIET-NSS,nssksriet@gmail.com
4	Awareness Program on YOGA	21.06.2017	117	KSRIET-YOGA CLUB,

  
**PRINCIPAL**

PRINCIPAL,  
K. S. R. INSTITUTE FOR  
ENGINEERING AND TECHNOLOGY,  
K. S. R. KALVI NAGAR,  
TIRUCHENGODE - 637 215,  
NAMAKKAL Dt, TAMIL NADU.



**KSR INSTITUTE FOR ENGINEERING AND TECHNOLOGY**

**TIRUCHENGODE-637 215**



**National Service Scheme (NSS)**

**REF: KSRIET/NSS/CIR/2017-2018/03**

**CIRCULAR**

**DATE: 26/06/2017**

Our KSRIET NSS is organizing "YOGA FOR FACULTIES" on June 30<sup>th</sup>, 2017 (Friday) at our EEE Seminar hall from 10.30 AM. We are inviting all our Teaching and Non Teaching faculties are asked to participate.

*All are invited*

  
NSS Programme Officer

  
Principal

Copy to

- The Principal Office,
- All Department HODs,
- Common Notice Board.

  
PRINCIPAL,  
K. S. R. INSTITUTE FOR  
ENGINEERING AND TECHNOLOGY,  
K. S. R. KALVI NAGAR,  
TIRUCHENGODE-637 215,  
NAMAKKAL DL, TAMIL NADU.

# KSR INSTITUTE FOR ENGINEERING AND TECHNOLOGY

## National Service Scheme

"Yoga for Faculties" On 30/06/2017

### Name List of Volunteers

Academic Year: 2017-2018

The following students are permitted to attend the Yoga:

S.NO	NAME OF THE STUDENT	YEAR/DEPT
1.	PRAKASH V	I-CSE
2.	ARUN KUMAR N	I-CSE
3.	KARTHIK T	I-IT
4.	HARIPRASATH K	I-IT
5.	GIRINATH S	I-IT
6.	ARULMOZHI M	I-IT
7.	KALIDASS R	I-IT
8.	MUKESH KANNA R	I-IT
9.	AJAYSIRIRAM K	I-IT
10.	CHANDRU M	I-IT
11.	SATHISHKUMAR V	I-IT
12.	KAVIN M	I-MECH
13.	DHANUSH ADIT R	I-IT
14.	KIRUBAKARAN K	I-MECH
15.	NAVEEN V	I-MECH
16.	HARIPRASATH K	I-IT
17.	DINESHKUMAR P	I-IT
18.	SAKTHIVEL P	I-MECH
19.	SANTHOSHKUMAR A	I-CSE
20.	KOTEESHWARAN PN	I-CSE
21.	MANORANJITH M	I-CSE
22.	RAJARAVEENDHAR G R	I-IT
23.	SAANTHOSHBALAJI S N	I-IT
24.	SANGEETHA M	I-CSE
25.	SHAILAA P M	I-IT

  
PRINCIPAL  
K. S. R. INSTITUTE FOR  
ENGINEERING AND TECHNOLOGY  
K. S. R. KALVINAGAR,  
TIRUCHENGOORE-637 215,  
NAMAKKAL DI, TAMIL NADU.

26.	SHIVANI N	I-IT
27.	SIVASANKARI R	I-IT
28.	VALENTEENA COLLINS J P	I-CSE
29.	NAVEEN M	I-MECH
30.	SURESHMOORTHY P	I-MECH
31.	VEERALAKSHMI S	I-CSE
32.	KARTHIK A S	I-MECH
33.	NIKHIL S	I-MECH
34.	NITHISH M	I-MECH
35.	VINOTHINI R	I-IT
36.	SRIRAM S	I-IT
37.	PRIYADHARSHINI P	I-IT
38.	PRADHAP R	I-MECH
39.	KATHIRVEL M	I-MECH
40.	ARUN R	II-CSE
41.	BARATH K	II-CSE
42.	NAVANANDHINI E	II-ECE
43.	NANDHAKUMAR P	II-ECE
44.	NANDHAKUMARAN R	II-ECE
45.	NARESH KUMAR S	II-ECE
46.	SANTHOSHKUMAR J	II-ECE
47.	SATHYAMOORTHI K	II-ECE
48.	SELLAKRISHNARAJA S	II-ECE
49.	BOOPATHY K M	II-MECH
50.	PREMNATH R	II-CSE
51.	PRIYANKA V	II-CSE
52.	VENMATHI S	II-CSE
53.	ARULIEESWARAN R	II-ECE
54.	ASWIN S	II-ECE
55.	KARTHIKEYAN S	II-ECE
56.	KAVINKUMAR R	II-MECH

  
 PRINCIPAL,  
 K. S. R. INSTITUTE FOR  
 ENGINEERING AND TECHNOLOGY  
 K. S. R. KALVI NAGAR  
 TIRUCHENGODE-612 022,  
 NAMAKKAL DL, TAMIL NADU.

57.	KEERTHIVASAN S	II-MECH
58.	SHILPA B	II-CSE
59.	SRUTHI S	II-CSE
60.	SUBHASREE S	II-CSE
61.	SWETHA B	II-CSE
62.	JEEVITHA R	II-CSE
63.	MANJULA R	II-CSE
64.	VINOTHMANI M	II-MECH
65.	VISHNU A	II-MECH
66.	ILAKIYA S	II-CSE
67.	JAYASHRI M	II-ECE
68.	KAJAPATHY V	II-ECE
69.	NANDHAGOBAL S	II-MECH
70.	NAVINKUMAR M	II-MECH
71.	PRAVEEN R	II-MECH
72.	PRAVEENKUMAR S	II-MECH
73.	SHAKTHI R.M	II-MECH
74.	RAGAVENDHAR S	II-MECH
75.	RAJKUMAR S	II-MECH
76.	NAMBIRAJ J	II-MECH
77.	MANOJ KUMAR V	II-EEE
78.	PREMKUMAR G	II-EEE

NSS PROGRAMME OFFICER

PRINCIPAL  
K. S. R. INSTITUTE FOR  
ENGINEERING AND TECHNOLOGY,  
K. S. R. KALIPPAKAR,  
TIRUVALETTUR-637 215,  
NARAYANIPET, TAMIL NADU.

PRINCIPAL

# K S R INSTITUTE FOR ENGINEERING AND TECHNOLOGY

TIRUCHENGODE – 637 215

## NATIONAL SERVICE SCHEME (NSS)

### Yoga for Faculties – Report

Academic Year: 2017-18

<b>Name of the Programme</b>	Yoga for Faculties		
<b>Date &amp; Time</b>	30/06/2017 & 10.30 AM	<b>Venue</b>	EEE Seminar hall
<b>Chief Guest/Resource Person</b>	A.Murugesan AP/EEE, KSRIET	<b>No of NSS Volunteers involved in the activity</b>	20
		<b>No of Beneficiaries</b>	62
<b>About Programme /Activity</b>	On 30st June, 2017 International Yoga day was celebrated by NSS volunteers. A practice session and demonstration to our faculty members were organized by Prof .A.Murugesan AP/EEE in our EEE Seminar hall. Sixty two of our faculty were participated and get benefitted.		



Yoga for Faculties

*[Signature]*  
NSS Coordinator

*[Signature]*  
PRINCIPAL,  
K. S. R. INSTITUTE FOR  
ENGINEERING AND TECHNOLOGY,  
K. S. R. KALVI NAGAR,  
TIRUCHENGODE-637 215,  
NAMAKKAL DL, TAMIL NADU.

*[Signature]*  
Principal



**KSR INSTITUTE FOR ENGINEERING AND TECHNOLOGY**

**TIRUCHENGODE**

**National Service Scheme (NSS)**





**REF: KSRIET/NSS/CIR/2017-2018/05**

**CIRCULAR**

**DATE: 06/7/2017**

We are organizing "Blood Donation Drive" in EEE Seminar Hall on 12 July, 2017. In this regard, the students who are willing to donate their blood, Enroll your name Mr.A.Mohanraj AP/Mech on or before 08/07/2017.

  
NSS Programme Officer

  
Principal

Copy to

- The Principal Office,
- All Department HODs,
- Common Notice Board.

  
PRINCIPAL,  
K. S. R. INSTITUTE FOR  
ENGINEERING AND TECHNOLOGY,  
K. S. R. KALVINAGAR,  
TIRUCHENGODE-637 215,  
NAMAKKAL Dt, TAMIL NADU.

**KSR INSTITUTE FOR ENGINEERING AND TECHNOLOGY**

**National Service Scheme**

**"Blood Donation Drive" on 12/07/2017**

**Name List of Volunteers**

**Academic Year: 2017-2018**

The following students are permitted to attend the Blood Donation:

S.NO	NAME OF THE STUDENT	YEAR/DEPT
1.	KALIDASS R	I-IT
2.	MUKESH KANNA R	I-IT
3.	AJAYSIRIRAM K	I-IT
4.	CHANDRU M	I-IT
5.	SATHISHKUMAR V	I-IT
6.	KAVIN M	I-MECH
7.	DHANUSH ADIT R	I-IT
8.	KIRUBAKARAN K	I-MECH
9.	NAVEEN V	I-MECH
10.	HARIPRASATH K	I-IT
11.	DINESHKUMAR P	I-IT
12.	SAKTHIVEL P	I-MECH
13.	SANTHOSHKUMAR A	I-CSE
14.	KOTEESHWARAN PN	I-CSE
15.	MANORANJITH M	I-CSE
16.	RAJARAVEENDHAR G R	I-IT
17.	SAANTHOSHBALAJI S N	I-IT
18.	SANGEETHA M	I-CSE
19.	SHAILAA P M	I-IT
20.	SHIVANI N	I-IT
21.	SIVASANKARI R	I-IT
22.	VALENTEENA COLLINS J P	I-CSE
23.	NAVEEN M	I-MECH
24.	SURESHMOORTHY P	I-MECH
25.	VEERALAKSHMI S	I-CSE

  
PRINCIPAL,  
K. S. R. INSTITUTE FOR  
ENGINEERING AND TECHNOLOGY,  
K. S. R. KALVI NAGAR,  
TIRUCHENGODE-637 215,  
NAMAKKAL Dt, TAMIL NADU.



26.	KARTHIK A S	I-MECH
27.	NIKHIL S	I-MECH
28.	NITHISH M	I-MECH
29.	VINOTHINI R	I-IT
30.	SRIRAM S	I-IT
31.	PRIYADHARSHINI P	I-IT
32.	PRADHAP R	I-MECH
33.	KATHIRVEL M	I-MECH
34.	ARUN R	II-CSE
35.	BARATH K	II-CSE
36.	NAVANANDHINI E	II-ECE
37.	NANDHAKUMAR P	II-ECE
38.	NANDHAKUMARAN R	II-ECE
39.	NARESH KUMAR S	II-ECE
40.	SANTHOSHKUMAR J	II-ECE
41.	SATHYAMOORTHI K	II-ECE
42.	SELLAKRISHNARAJA S	II-ECE
43.	ASWIN S	II-ECE
44.	KARTHIKEYAN S	II-ECE
45.	KAVINKUMAR R	II-MECH
46.	KEERTHIVASAN S	II-MECH
47.	SHILPA B	II-CSE
48.	SRUTHI S	II-CSE
49.	SUBHASREE S	II-CSE
50.	SWETHA B	II-CSE
51.	JEEVITHA R	II-CSE
52.	MANJULA R	II-CSE
53.	VINOTHMANI M	II-MECH
54.	VISHNU A	II-MECH
55.	ILAKIYA S	II-CSE
56.	JAYASHRI M	II-ECE
57.	KAJAPATHY V	II-ECE

  
**PRINCIPAL,**  
**K. S. R. INSTITUTE FOR**  
**ENGINEERING AND TECHNOLOGY,**  
**K. S. R. KALVI NAGAR,**  
**TIRUCHENGODE - 637 215,**  
**NAMAKKAL Dt, TAMIL NADU.**

58.	NANDHAGOBAL S	II-MECH
59.	NAVINKUMAR M	II-MECH
60.	PRAVEEN R	II-MECH
61.	PRAVEENKUMAR S	II-MECH
62.	RAGAVENDHAR S	II-MECH

NSS PROGRAMME OFFICER

PRINCIPAL  
K. S. N. INSTITUTIONS FOR  
ENGINEERING AND TECHNOLOGY,  
K. S. N. KALVI NAGAR,  
TIRUCHENGOODE-637 215,  
NAMAKKAL DI, TAMIL NADU.

PRINCIPAL

# K S R INSTITUTE FOR ENGINEERING AND TECHNOLOGY

TIRUCHENGODE – 637 215

## NATIONAL SERVICE SCHEME (NSS)

### Blood Donation Drive – Report

Academic Year: 2017-18

<b>Name of the Programme</b>	Blood Donation Drive		
<b>Date &amp; Time</b>	12/07/2017 & 11:00 AM	<b>Venue</b>	EEE Seminar hall
<b>Chief Guest/Resource Person</b>	Dr.M.Venkatesan Principal	<b>No of NSS Volunteers involved in the activity</b>	32
		<b>No of Beneficiaries</b>	62
<b>About Programme /Activity</b>	Our KSRIET NSS jointly organized with JCI, Erode we, the blood donation camp was organized on 12 July 2017 in our EEE Seminar hall. Our Principal Dr.M.Venkatesan, Inaugurated and provide certificates to the donors. In this programme 32 NSS Volunteers are utilized to arrange the programme and 62 students get benefited		

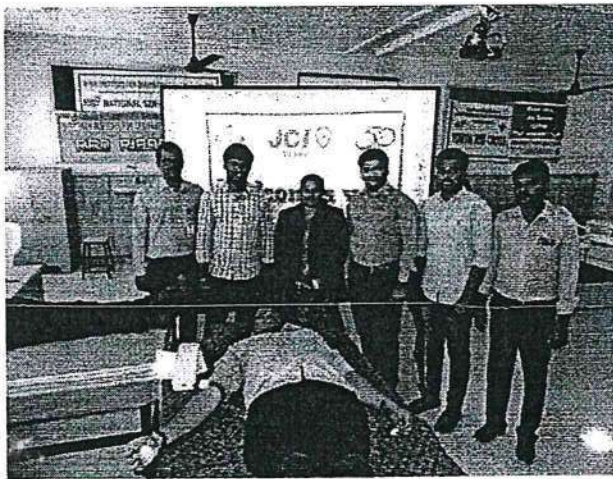

Blood – Donation Drive

*D. Srinivasan*  
NSS Coordinator

*[Signature]*  
PRINCIPAL,  
K. S. R. INSTITUTE FOR  
ENGINEERING AND TECHNOLOGY,  
K. S. R. KALVI NAGAR,  
TIRUCHENGODE-637 215,  
NAMAKKAL Dt, TAMIL NADU.

*[Signature]*  
Principal



**KSR INSTITUTE FOR ENGINEERING AND TECHNOLOGY**

**TIRUCHENGODE**

**National Service Scheme (NSS)**



**REF: KSRIET/NSS/CIR/2017-2018/08**

**CIRCULAR**

**DATE: 29/11/2017**

"An Essay Competition on AIDS awareness" will be organized on 01 December, 2017. In this regard, the interested students are asked to participate in Mechanical Seminar hall on 1<sup>st</sup> December, 2017 at 10.00 AM. For further any clarification contact Mr.A.MOHANRAJ AP/MECH.

  
NSS Programme Officer

  
Principal

Copy to

- The Principal Office,
- All Department HODs,
- Common Notice Board.

  
PRINCIPAL,  
K. S. R. INSTITUTE FOR  
ENGINEERING AND TECHNOLOGY,  
K. S. R. KALVI NAGAR,  
TIRUCHENGODE-637 215,  
NAMAKKAL Dt, TAMIL NADU.

**KSR INSTITUTE FOR ENGINEERING AND TECHNOLOGY**

**National Service Scheme**

**"Essay Competition on Aids Awareness" On 01/12/2017**

**Name List of Volunteers**

**Academic Year: 2017-2018**

The following students are permitted to attend the event:

S.NO	NAME OF THE STUDENT	YEAR/DEPT
1.	DINESHKUMAR K	I-CSE
2.	VIGNESH S	I-CSE
3.	MARIMUTHU R	I-CSE
4.	DERIL CHARLESS K	I-CSE
5.	BABU R	I-CSE
6.	KAILASH K	I-CSE
7.	HARISH P	I-CSE
8.	KESAVAN S	I-CSE
9.	PRASANTH T	I-CSE
10.	PURUSOTHAMAN R	I-CSE
11.	GUNA M	I-CSE
12.	PRAKASH V	I-CSE
13.	ARUN KUMAR N	I-CSE
14.	PREMNATH R	II-CSE
15.	PRIYANKA V	II-CSE
16.	VENMATHI S	II-CSE
17.	ARULIEESWARAN R	II-ECE
18.	ASWIN S	II-ECE
19.	KARTHIKEYAN S	II-ECE
20.	KAVINKUMAR R	II-MECH
21.	KEERTHIVASAN S	II-MECH
22.	SHILPA B	II-CSE
23.	SRUTHI S	II-CSE
24.	SUBHASREE S	II-CSE
25.	DINESHKUMAR K	I-CSE
26.	VIGNESH S	I-CSE

NSS PROGRAMME OFFICER

PRINCIPAL,  
K. S. R. INSTITUTE FOR  
ENGINEERING AND TECHNOLOGY,  
K. S. R. KALVI NAGAR,  
TIRUCHENGODE-637 215,  
NAMAKKAL DL, TAMIL NADU.

PRINCIPAL

# K S R INSTITUTE FOR ENGINEERING AND TECHNOLOGY

TIRUCHENGODE - 637 215

## NATIONAL SERVICE SCHEME (NSS)

### Essay Competition on AIDS Awareness - Report

Academic Year: 2017-18

<b>Name of the Programme</b>	Essay Competition on AIDS Awareness		
<b>Date &amp; Time</b>	01/12/2017 & 11:00 AM	<b>Venue</b>	EEE Seminar Hall
<b>Chief Guest/Resource Person</b>	<b>No of NSS Volunteers involved in the activity</b>		26
	<b>No of Beneficiaries</b>		26
<b>About Programme /Activity</b>	Our KSRIET NSS Conducted "Essay Competition on AIDS awareness" on 01 December, 2017. Twenty-Six Essays had been submitted by our college students. Based on the content the price announced and distributed		

AIDS - Acquired immunodeficiency Syndrome, is the complex illness with a wide range of complications and symptoms. AIDS is the final stage of HIV. When individuals reach this stage, they are at high risk for opportunistic infections due to their badly damaged immune system.

Signs and symptoms commonly seen in the early stages of HIV include: Fever, chills, Rash, Night sweats, Muscle aches, Sore throat, Fatigue, Swollen lymph nodes, ulcers in the mouth.

Reducing Your Sexual Risk is one way to prevent the transmission of HIV.

Practicing abstinence: If you have no sexual contact with another individual, you are 100 percent protected from contracting HIV through anal, oral (or) vaginal sex which are the main ways that HIV is transmitted.



PRINCIPAL,  
K. S. R. INSTITUTE FOR  
ENGINEERING AND TECHNOLOGY,  
K. S. R. KALVINGAR,  
TIRUCHENGODE-637 215,  
NAMAKKAL DISTRICT, TAMIL NADU.

Essay Competition on AIDS Awareness

  
NSS Coordinator

  
Principal

**PERMISSION LETTER**

From

The Co-ordinator,  
Yoga Club,  
KSRIET,  
Tiruchengode.

To

The Principal,  
KSRIET,  
Tiruchengode.

Respected Sir,

**Sub. :- Requesting permission to conduct Awareness Program on YOGA – Reg.**

In view of International Yoga day, Yoga club of our college has planned to conduct “**an awareness program on YOGA**” for our students and faculty members on 21.06.2017. Hence you are requested to give permission and do the needful.

Thanking you.

Yours faithfully,

*S. Chellu*  
16/06/2017

[S. CHELLURAI]

Date: 16-06-2017

Place: KSRIET, Tiruchengode.

*[Handwritten signature]*  
16/06/17

*[Handwritten signature]*

PRINCIPAL,  
K. S. R. INSTITUTE FOR  
ENGINEERING AND TECHNOLOGY,  
K. S. R. KALVI NAGAR,  
TIRUCHENGODE-637 215,  
NAMAKKAL DI. TAMIL NADU.

# K S R INSTITUTE FOR ENGINEERING AND TECHNOLOGY

TIRUCHENGODE - 637 215

Ref.: KSRIET/YOGA/CIR/2017-18/001

DATE: 20.06.2017

## YOGA CLUB

### CIRCULAR

This is to inform all the HoDs, Faculty members & students that our Yoga Club is organizing "Awareness Program on YOGA" for the students & faculty members on 21.06.2017 in view of International Yoga Day. In this regard, Class advisors are asked to assemble the willing students in the respective venue as per the schedule given below.

Time	Venue
9.00 am to 11.00 am	EEE Seminar Hall (For Girls)
	ECE Seminar Hall (For Boys)
	MECH Seminar Hall (For Boys)

  
COORDINATOR  
(YOGA CLUB)

  
PRINCIPAL

  
PRINCIPAL,  
K. S. R. INSTITUTE FOR  
ENGINEERING AND TECHNOLOGY,  
K. S. R. KALVI NAGAR,  
TIRUCHENGODE-637 215,  
NAMAKKAL Dt, TAMIL NADU.



**"Awareness programme on YOGA"**

**list of participants :**

S.No.	BRANCH	YEAR	NAME OF THE STUDENT
1	CSE	I YEAR	ARUN R
2			BARATH K
3			DEEPAK SURIYA A
4			JEEVITHA R
5			KAMALESH M
6			LAXMANCIBI S
7			VISVESWARAN B
8		II YEAR	BOOPATHIRAJA M
9			DINESH J
10			ELAKKIYA T E
11			MUNUSAMY R
12			NAVEENA D
13			RAJAGANAPATHY T
14			SABANA YASMINE A
15		ThERASHA JENIFAR B	
16		III YEAR	DIVYA R
17			GEETHANJALI M
18			JiyATHKHAN A
19			KEERTHANA D
20			PRIYANKA R
21			RAKUL M
22			KOKILA R
23		IV YEAR	MANIMEGALAI I
24			THILAKA S
25			VIDHYA D
26			YUVARAJ A
27	EEE	I YEAR	DIVYADEVI V
28			GANESHBABU V
29			LOGESHWARAN V
30			MADHUMITHA J S
31		II YEAR	ELANCHEZHIAN P
32			GAYATHRI K
33			GOBIKRISHNAN R
34			PAVITHRA M
35		III YEAR	DIYANA S
36			GANAPATHY M
37			THIYAGARAJAN S
38			UTHIRAKUMAR E
39		IV YEAR	BHUVANAKUMAR N
40			DHIVAHAR R
41			VAISNAVI L
42			ECE
43	KAJAPATHY V		
44	MEENA A		
45	ROSHINI T		
46	SAKTHIPRIYA S		
47	THAMARA KANNAN A S		
48			DHARANI R
49			DHAYALI G

  
**PRINCIPAL,**  
**K. S. R. INSTITUTE FOR**  
**ENGINEERING AND TECHNOLOGY,**  
**K. S. R. KALVI NAGAR,**  
**TIRUCHENGODE-637 215,**  
**NAMAKKAL Dt, TAMIL NADU.**

S.No.	BRANCH	YEAR	NAME OF THE STUDENT
50	ECE	II YEAR	PRATHEEP S
51			RAMKUMAR L
52			MUTHU KUMAR P
53			NARESH N
54		III YEAR	DURKA DEVI S
55			ELIZABETH N J
56			NIVETHA A
57			OVIYA T
58			RAVI VARMA B
59			SANGEETHA N
60		UMA P	
61		IV YEAR	JEFFIN JOSE
62			KARTHICK B
63			NANDHINI A
64			MOHANKUMAR G
65			SHANKARGURU M
66	MANIKANDAN A		
67	MECH	I YEAR	BOOPATHY K M
68			CHANDRASEKAR K
69			LOGESH S
70			MADHANKUMAR L
71			RUTHRANNAN B
72			SABARISH R
73		II YEAR	BHARATHI K N
74			DUDIARASU S
75			ELANGO V
76			GABY SACHIN S
77			PUVIYARASAN N
78			RAGU S
79		III YEAR	DINESHKUMAR M
80			ELAMKABILAN P
81			KUMARAN E
82			LAVANYA S
83	MUTHURAJ S		
84	NAINAR MOHAMED S		
85	MECH	III YEAR	RANJITH KUMAR S
86			SABAREESAN M
87			VIJAY S
88		IV YEAR	DINESHKUMAR T
89			ENIYAVELAN K
90			GOBALAKRISHNAN A
91	NITHIN T		
92	PADMANABHAN S		
93	SIVA S		
94	MECH	I YEAR	NESHAK KUMAR S
95			OVIYA A
96			PRIYADHARSHINI G
97			SAKTHIRAVIKUMAR M
98			VINOTH M
99			YAKSHEETA V
100		II YEAR	BALAJI S
101			CHIRAAG L
102			DEEPA K

  
 PRINCIPAL,  
 K. S. R. INSTITUTE FOR  
 ENGINEERING AND TECHNOLOGY,  
 K. S. R. KALVI NAGAR,  
 TIRUCHENGODE-637 215,  
 NAMAKKAL Dt. TAMIL NADU.

S.No.	BRANCH	YEAR	NAME OF THE STUDENT
103	IT	II YEAR	RINESH R
104			SARAVANAPRIYA R
105			VINEETH PRAVEEN V
106		III YEAR	ILAKKIYA S
107			KARTHIK P
108			MEPHY MONY
109			NANTHAKUMAR S
110			PAVITHRA S
111			VINITHA K
112		IV YEAR	REVATHY V P
113			SAMPATHKUMAR S
114			VINODH S
115			BALAJI V
116			ELAVARASAN S
117			SHIBANI I

  
21/06/2017

CO-ORDINATOR  
(YOGIA CLUB)

  
PRINCIPAL,  
K. S. R. INSTITUTE FOR  
ENGINEERING AND TECHNOLOGY,  
K. S. R. KALVI NAGAR,  
TIRUCHENGODE-637 215,  
NAMAKKAL Dt, TAMIL NADU.

**K S R INSTITUTE FOR ENGINEERING AND TECHNOLOGY**

**INTERNATIONAL YOGA DAY**

**AWARENESS PROGRAMME- 21.06.17**

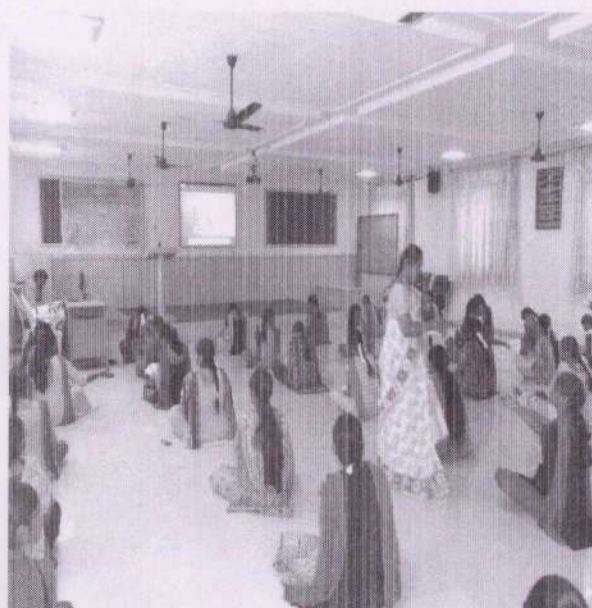
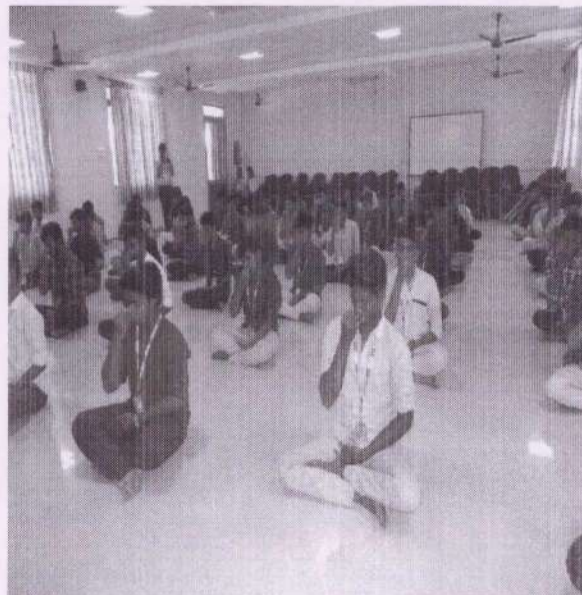
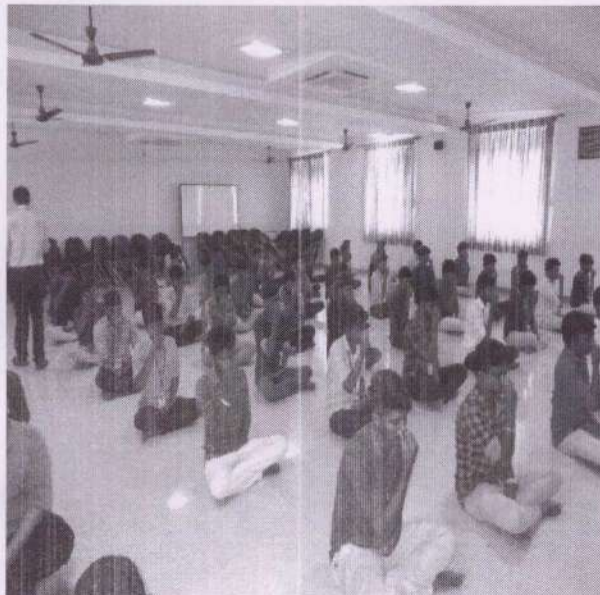

  
**PRINCIPAL,  
K. S. R. INSTITUTE FOR  
ENGINEERING AND TECHNOLOGY,  
K. S. R. KALVI NAGAR,  
TIRUCHENGOODE - 637 015,  
NAMAKKAL. DT, TAMIL NADU.**



**KSR INSTITUTE FOR ENGINEERING AND TECHNOLOGY,  
TIRUCHENGODE- 637215  
YOGA CLUB**

**Report Summary**

<b>Name of the Club:</b>	Yoga Club		
<b>Academic Year:</b>	2017- 2018	<b>Date &amp; Time:</b>	21.06.2017 & 9 am
<b>Name of the Programme:</b>	“ Awareness programme on YOGA”		
<b>Venue:</b>	EEE Seminar hall, ECE Seminar hall & MECH Seminar hall	<b>No. of Participants Attended :</b>	117

**Brief about the Program:**

In order to create awareness about YOGA among our college students & Faculty members, Yoga Club has been conducting awareness programme every year.

In this academic year (2017-18) also, we have conducted an awareness programme on YOGA on 21.06.2017 from 9 am to 11 am in various seminar halls (EEE Seminar hall, ECE Seminar hall & Mechanical Seminar hall). Around 117 students from various departments have participated & benefitted in this awareness programme.

Three Trainers from Isha Yoga Centre, Coimbatore have explained the importance of YOGA to keep our body and mind healthy & taught some simple Yoga Exercises by playing the videos.

This programme was very useful to our students to keep both mental & physical health.

Coordinator

(Yoga Club)

Principal

**PRINCIPAL,  
K. S. R. INSTITUTE FOR  
ENGINEERING AND TECHNOLOGY,  
K. S. R. KALVI NAGAR,  
TIRUCHENGODE-637 215,  
NAMAKKAL Dt, TAMIL NADU.**

# ***4. ICT/COMPUTING SKILLS***

**K S R INSTITUTE FOR ENGINEERING AND TECHNOLOGY**

**ICT/COMPUTING SKILLS CONSOLIDATED LIST**

**Academic Year:2017-2018**

<b>S.NO.</b>	<b>Name of the capability enhancement program</b>	<b>Date of implementation (DD-MM-YYYY)</b>	<b>Number of students enrolled</b>	<b>Name of the agencies/consultants involved with contact details (if any)</b>
1	Java & Data Structure Training Programme	12.06.2017	131	E-Box (Amphisoft Technologies)
2	Practice Session during SSD on Input output Statements and Operators, Conditional statements, Looping statements, Functions & pointers	30.06.2017	272	Internal Department Faculty
3	Programming in C - Input Output Statements and Operators, Conditional Statements, Looping Constructs I, Looping Constructs II, Functions and Pointers, 2-D Arrays, Strings, Recursion & Structures	03.07.2017	261	Internal E Box - Programming Skill Enhancement

  
PRINCIPAL,  
K. S. R. INSTITUTE FOR  
ENGINEERING AND TECHNOLOGY,  
K. S. R. KALVI NAGAR,  
TIRUCHENGODE-637 215,  
NAMAKKAL Dt, TAMIL NADU.

4	Programming in Data Structures - Linked list, Queue and Lists Applications, Trees, Heaps & Graphs	07.08.2017	173	Internal E Box - Programming Skill Enhancement
5	Programming in C & Practice using Skillrack tool	04.12.2017	173	Internal Department Faculty
6	AUTOCAD	07.08.2017	99	ksriet,hod_mech@ksriet.ac.in
7	CREO- INDUSTRIAL DESIGN	29.05.2017	92	ksriet,hod_mech@ksriet.ac.in
8	SOLIDWORKS	11.12.2017	76	ksriet,hod_mech@ksriet.ac.in
9	CREO- AUTOMATION AND PRODUCTION	05.06.2017	93	ksriet,hod_mech@ksriet.ac.in
10	CCP- PIPING	04.12.2017	80	ksriet,hod_mech@ksriet.ac.in

  
PRINCIPAL

PRINCIPAL,  
K. S. R. INSTITUTE FOR  
ENGINEERING AND TECHNOLOGY,  
K. S. R. KALVI NAGAR,  
TIRUCHENGODE - 637 215,  
NAMAKKAL Dt, TAMIL NADU.



This is to inform all the HoDs and department Training and Placement coordinators that the Training Programmes on Java & Data Structures for IV year students for the academic year 2017 - 2018 have been scheduled. All the registered students should attend the Training Programme. If any student skips this Training Programme without proper permission from the respective HoDs, he / she will not be permitted for any further Training Programme and campus recruitment process. Proper Dress Code is mandatory.

### Final year Training Schedule (Batch 2014 - 2018)

S.No	Department	Slot Number	Topics	Dates Planned for Training	No of Days
1	CSE IT	I	JAVA & Data Structures	12.06.2017 to 16.06.2017	5
2	ECE EEE	II		19.06.2017 to 23.06.2017	5
3	MECH	III		27.03.2017 to 30.06.2017	4
Total No of Days Training					14

#### Session Timings:

Forenoon Session: 09:15am - 12:30 pm

Afternoon Session: 01:30pm - 04:15 pm

Break: 10.45 am to 11.00 am

Lunch: 12.30 pm to 01.30 pm

*[Signature]*  
T&P OFFICER

*[Signature]*  
T&P COORDINATOR

*[Signature]*  
PRINCIPAL

#### Copy to:

1. All HoDs
2. Notice Board

*[Signature]*  
PRINCIPAL,  
K. S. R. INSTITUTE FOR  
ENGINEERING AND TECHNOLOGY,  
K. S. R. KALVI NAGAR,  
TIRUCHENGODE - 637 215,  
NAMAKKAL Dt, TAMIL NADU.

**Training and Placement Cell.  
E BOX - TRAINING PROGRAMME ATTENDANCE.**

**BATCH : 2014 - 2018  
Year / Sem: IV / VII**

**Academic Year: 2017 - 201**

**Staff Incharge: M. Soundararaj Saravanan**

S.No	Reg No	Name	Branch	12.6.17			13.6.17			14.6.17			15.6.17			16.6.17			19.6.17		
				FN	FN	AN	FN	FN	AN	FN	FN	AN	FN	FN	AN	FN	FN	AN	FN	FN	AN
1	731614104007	DEEPAKFERLANDEZ M	CSE	/	/	/	/	/	/	/	/	/	/	/	/	/	/	/	/	/	/
2	731614104009	GEETHANJALI M	CSE	N	N	N	N	N	N	N	N	N	N	N	N	N	N	N	N	N	N
3	731614104012	JASRE A	CSE	/	/	/	/	/	/	/	/	/	/	/	/	/	/	/	/	/	/
4	731614104701	SOWMIYA S	CSE	N	N	N	N	N	N	N	N	N	N	N	N	N	N	N	N	N	N
5	731614106001	ABINAYA R	ECE	/	/	/	/	/	/	/	/	/	/	/	/	/	/	/	/	/	/
6	731614106007	DEEPAK RAJU C	ECE	/	/	/	/	/	/	/	/	/	/	/	/	/	/	/	/	/	/
7	731614106008	DEEPAN KUMAR S	ECE	/	/	/	/	/	/	/	/	/	/	/	/	/	/	/	/	/	/
8	731614106016	GOPIKA N	ECE	/	/	/	/	/	/	/	/	/	/	/	/	/	/	/	/	/	/
9	731614106025	KALAI PRIYA N	ECE	/	/	/	/	/	/	/	/	/	/	/	/	/	/	/	/	/	/
10	731614106027	KANMANI R	ECE	/	/	/	/	/	/	/	/	/	/	/	/	/	/	/	/	/	/
11	731614106045	NAAGA NAVEEN KUMAR.V	ECE	/	/	/	/	/	/	/	/	/	/	/	/	/	/	/	/	/	/
12	731614106046	NANDHINI M	ECE	/	/	/	/	/	/	/	/	/	/	/	/	/	/	/	/	/	/
13	731614106050	PADMAPRIYA.E	ECE	/	/	/	/	/	/	/	/	/	/	/	/	/	/	/	/	/	/
14	731614106051	PARTHASARATHI.M.M	ECE	/	/	/	/	/	/	/	/	/	/	/	/	/	/	/	/	/	/
15	731614106058	PRIYA P	ECE	/	/	/	/	/	/	/	/	/	/	/	/	/	/	/	/	/	/
16	731614106070	SHARANYA A	ECE	/	/	/	/	/	/	/	/	/	/	/	/	/	/	/	/	/	/
17	731614106077	SUBATHRA S	ECE	/	/	/	/	/	/	/	/	/	/	/	/	/	/	/	/	/	/
18	731614106078	SUBRAMANIYAM K	ECE	/	/	/	/	/	/	/	/	/	/	/	/	/	/	/	/	/	/
19	731614106082	THAMARAIKANNAN.S	ECE	/	/	/	/	/	/	/	/	/	/	/	/	/	/	/	/	/	/
20	731614106085	VINCTHINI P	ECE	/	/	/	/	/	/	/	/	/	/	/	/	/	/	/	/	/	/
21	731614105003	ARAVINDHAN B	EEE	/	/	/	/	/	/	/	/	/	/	/	/	/	/	/	/	/	/
22	731614105004	BALACHANDAR K R	EEE	/	/	/	/	/	/	/	/	/	/	/	/	/	/	/	/	/	/
23	731614105009	DHIVAGAR A	EEE	/	/	/	/	/	/	/	/	/	/	/	/	/	/	/	/	/	/
24	731614105033	MATHANA GOPAL G	EEE	/	/	/	/	/	/	/	/	/	/	/	/	/	/	/	/	/	/
25	731614105312	THIRUMOORTHIG	EEE	/	/	/	/	/	/	/	/	/	/	/	/	/	/	/	/	/	/
26	731614105034	MOTHINATH S	EEE	/	/	/	/	/	/	/	/	/	/	/	/	/	/	/	/	/	/
27	731614105035	MOULIDHARAN S	EEE	/	/	/	/	/	/	/	/	/	/	/	/	/	/	/	/	/	/
28	731614105042	PRAVEENKUMAR B	EEE	/	/	/	/	/	/	/	/	/	/	/	/	/	/	/	/	/	/
29	731614105043	PRAVIEEN M K	EEE	/	/	/	/	/	/	/	/	/	/	/	/	/	/	/	/	/	/
30	731614105051	RANJITHKUMAR S	EEE	/	/	/	/	/	/	/	/	/	/	/	/	/	/	/	/	/	/
31	731614105052	RAVINDRAN S	EEE	/	/	/	/	/	/	/	/	/	/	/	/	/	/	/	/	/	/
32	731614105053	ROKESH KUMAR R	EEE	/	/	/	/	/	/	/	/	/	/	/	/	/	/	/	/	/	/
33	731614105056	SARAVANAN V	EEE	/	/	/	/	/	/	/	/	/	/	/	/	/	/	/	/	/	/
34	731614105066	TAMIL SELVAN P	EEE	/	/	/	/	/	/	/	/	/	/	/	/	/	/	/	/	/	/
35	731614105068	UTHIRAKUMAR E	EEE	/	/	/	/	/	/	/	/	/	/	/	/	/	/	/	/	/	/
36	731614105074	VINOTH KUMAR R	EEE	/	/	/	/	/	/	/	/	/	/	/	/	/	/	/	/	/	/
37	731614105077	YUVARAJ V	EEE	/	/	/	/	/	/	/	/	/	/	/	/	/	/	/	/	/	/
38	731614205001	GNANASEKAR N	IT	/	/	/	/	/	/	/	/	/	/	/	/	/	/	/	/	/	/
39	731614205013	VIJAY S	IT	/	/	/	/	/	/	/	/	/	/	/	/	/	/	/	/	/	/
40	731614205303	GOKUL K	IT	/	/	/	/	/	/	/	/	/	/	/	/	/	/	/	/	/	/

731614106012 - S. Divya Devi ECE  
731614105039 - T. nandhini EEE

K. S. R. COLLEGE FOR  
ENGINEERING AND TECHNOLOGY,  
K. S. R. KAMPAKAR,  
TRICHENGOODE - 637 215,  
NAMAKKAL DISTRICT, TAMIL NADU.



**Training and Placement Cell**  
**E BOX - TRAINING PROGRAMME ATTENDANCE**

BATCH : 2014 - 2018

Academic Year: 2017 - 2018

Year / Sem: IV / VII

Staff Incharge:

S. No	Reg No	Name	Branch	20.6.17		21.6.17		22.6.17		23.6.17		27.6.17		28.6.17		30/9	
				FN	FN	AN	A3	FN	FN	AN	A3	FN	FN	AN	A3	FN	FN
1	731614104007	DEEPAK FERNANDEZ M	CSE	/	/	/	/	/	/	/	/	/	/	/	/	/	/
2	731614104012	JAISRE A	CSE	PP	/	/	/	/	/	/	/	/	/	/	/	/	/
3	731614106001	ABINAYA R	ECE	/	/	/	/	/	/	/	/	/	/	/	/	/	/
4	731614106007	DEEPAK RAJU C	ECE	/	/	/	/	/	/	/	/	/	/	/	/	/	/
5	731614106008	DEEPAN KUMAR S	ECE	/	/	/	/	/	/	/	/	/	/	/	/	/	/
6	731614106012	DURKA DEVI S	ECE	N	N												
7	731614106023	JOTHIPRAKASH R	ECE	N	N												
8	731614106016	GOPIKA N	ECE	/	/	/	/	/	/	/	/	/	/	/	/	/	/
9	731614106025	KALAI PRIYA N	ECE	/	/	/	/	/	/	/	/	/	/	/	/	/	/
10	731614106027	KANMANI R	ECE	/	/	/	/	/	/	/	/	/	/	/	/	/	/
11	731614106045	NAAGA NAVEEN KUMAR V	ECE	/	/	/	/	/	/	/	/	/	/	/	/	/	/
12	731614106046	NANDHINI M	ECE	/	/	/	/	/	/	/	/	/	/	/	/	/	/
13	731614106050	PADMAPRIYA E	ECE	/	/	/	/	/	/	/	/	/	/	/	/	/	/
14	731614106051	PARTHASARATHI M M	ECE	/	/	/	/	/	/	/	/	/	/	/	/	/	/
15	731614106070	SHARANYA A	ECE	/	/	/	/	/	/	/	/	/	/	/	/	/	/
16	731614106077	SUBATHRA S	ECE	/	/	/	/	/	/	/	/	/	/	/	/	/	/
17	731614106078	SUBRAMANIYAM K	ECE	/	/	/	/	/	/	/	/	/	/	/	/	/	/
18	731614106082	THAMARA KANNAN S	ECE	/	/	/	/	/	/	/	/	/	/	/	/	/	/
19	731614106085	VINOTHINI P	ECE	/	/	/	/	/	/	/	/	/	/	/	/	/	/
20	731614105003	ARAVINDHAN B	EEE	/	/	/	/	/	/	/	/	/	/	/	/	/	/
21	731614105004	BALACHANDAR K R	EEE	/	/	/	/	/	/	/	/	/	/	/	/	/	/
22	731614105009	DHIVAGAR A	EEE	/	/	/	/	/	/	/	/	/	/	/	/	/	/
23	731614105033	MATHANA GOPAL G	EEE	/	/	/	/	/	/	/	/	/	/	/	/	/	/
24	731614105312	THIRUMOORTHY G	EEE	/	/	/	/	/	/	/	/	/	/	/	/	/	/
25	731614105034	MOTHINATH S	EEE	/	/	/	/	/	/	/	/	/	/	/	/	/	/
26	731614105035	MOULIDHARAN S	EEE	/	/	/	/	/	/	/	/	/	/	/	/	/	/
27	731614105039	NANDHINI T	EEE	/	/	/	/	/	/	/	/	/	/	/	/	/	/
28	731614105042	PRAVEEN KUMAR B	EEE	a	a	a	/	/	/	/	/	/	/	/	/	/	/
29	731614105043	PRAVEEN M K	EEE	/	/	/	/	/	/	/	/	/	/	/	/	/	/
30	731614105051	RANJITH KUMAR S	EEE	/	/	/	/	/	/	/	/	/	/	/	/	/	/
31	731614105052	RAVINDRAN S	EEE	/	/	/	/	/	/	/	/	/	/	/	/	/	/
32	731614105053	ROKESH KUMAR R	EEE	/	/	/	/	/	/	/	/	/	/	/	/	/	/
33	731614105056	SARAVANAN V	EEE	/	/	/	/	/	/	/	/	/	/	/	/	/	/
34	731614105066	TAMIL SELVAN P	EEE	/	/	/	/	/	/	/	/	/	/	/	/	/	/
35	731614105068	UTHIRAKUMAR E	EEE	/	/	/	/	/	/	/	/	/	/	/	/	/	/
36	731614105074	VINOTH KUMAR R	EEE	/	/	/	/	/	/	/	/	/	/	/	/	/	/
37	731614105077	YUVARAJ V	EEE	/	/	/	/	/	/	/	/	/	/	/	/	/	/
38	731614205001	GNANASEKAR N	IT	/	/	/	/	/	/	/	/	/	/	/	/	/	/
39	731614205013	VIJAY S	IT	/	/	/	/	/	/	/	/	/	/	/	/	/	/
40	731614205303	GOKUL K	IT	/	/	/	/	/	/	/	/	/	/	/	/	/	/

No	Reg No	Name	Branch	Attendance																																																	
				F	N	A	N	A	N	A	N	A	N	A	N	A	N	A	N	A	N	A	N	A	N	A	N	A	N	A	N	A	N	A	N	A	N	A	N	A	N												
41	731614114029	DEVARAJ N	MECH	/	/	/	/	/	/	/	/	/	/	/	/	/	/	/	/	/	/	/	/	/	/	/	/	/	/	/	/	/	/	/	/	/	/	/	/	/	/												
42	731614114030	DHANASEKARAN A	MECH	/	/	/	/	/	/	/	/	/	/	/	/	/	/	/	/	/	/	/	/	/	/	/	/	/	/	/	/	/	/	/	/	/	/	/	/	/	/	/	/										
43	731614114031	DHANUSH KUMAR K	MECH	a	a	a	a	a	a	a	a	a	a	a	a	a	a	a	a	a	a	a	a	a	a	a	a	a	a	a	a	a	a	a	a	a	a	a	a	a	a	a	a	a									
44	731614114074	MAHENDRAN A	MECH	/	/	/	/	/	/	/	/	/	/	/	/	/	/	/	/	/	/	/	/	/	/	/	/	/	/	/	/	/	/	/	/	/	/	/	/	/	/	/	/	/	/								
45	731614114075	MANOJ ARAVINTH E R	MECH	/	/	/	/	/	/	/	/	/	/	/	/	/	/	/	/	/	/	/	/	/	/	/	/	/	/	/	/	/	/	/	/	/	/	/	/	/	/	/	/	/	/	/							
46	731614114086	MOHAN P	MECH	/	/	/	/	/	/	/	/	/	/	/	/	/	/	/	/	/	/	/	/	/	/	/	/	/	/	/	/	/	/	/	/	/	/	/	/	/	/	/	/	/	/	/							
47	731614114087	MOHAN S	MECH	/	/	/	/	/	/	/	/	/	/	/	/	/	/	/	/	/	/	/	/	/	/	/	/	/	/	/	/	/	/	/	/	/	/	/	/	/	/	/	/	/	/	/	/						
48	731614114102	NIVASAN K	MECH	/	/	/	/	/	/	/	/	/	/	/	/	/	/	/	/	/	/	/	/	/	/	/	/	/	/	/	/	/	/	/	/	/	/	/	/	/	/	/	/	/	/	/	/						
49	731614114122	RANJITH KUMAR M	MECH	/	/	/	/	/	/	/	/	/	/	/	/	/	/	/	/	/	/	/	/	/	/	/	/	/	/	/	/	/	/	/	/	/	/	/	/	/	/	/	/	/	/	/	/						
50	731614114123	RANJITH KUMAR S	MECH	/	/	/	/	/	/	/	/	/	/	/	/	/	/	/	/	/	/	/	/	/	/	/	/	/	/	/	/	/	/	/	/	/	/	/	/	/	/	/	/	/	/	/	/	/					
51	731614114124	SABAREESAN M	MECH	/	/	/	/	/	/	/	/	/	/	/	/	/	/	/	/	/	/	/	/	/	/	/	/	/	/	/	/	/	/	/	/	/	/	/	/	/	/	/	/	/	/	/	/	/	/				
52	731614114141	SRINATH V	MECH	/	/	/	/	/	/	/	/	/	/	/	/	/	/	/	/	/	/	/	/	/	/	/	/	/	/	/	/	/	/	/	/	/	/	/	/	/	/	/	/	/	/	/	/	/	/				
53	731614114146	SURYA M	MECH	a	a	a	a	a	a	a	a	a	a	a	a	a	a	a	a	a	a	a	a	a	a	a	a	a	a	a	a	a	a	a	a	a	a	a	a	a	a	a	a	a	a	a	a	a	a				
54	731614114154	VASANTH S	MECH	/	/	/	/	/	/	/	/	/	/	/	/	/	/	/	/	/	/	/	/	/	/	/	/	/	/	/	/	/	/	/	/	/	/	/	/	/	/	/	/	/	/	/	/	/	/	/			
55	731614114163	VIJAY S	MECH	/	/	/	/	/	/	/	/	/	/	/	/	/	/	/	/	/	/	/	/	/	/	/	/	/	/	/	/	/	/	/	/	/	/	/	/	/	/	/	/	/	/	/	/	/	/	/			
56		SHANKAR RAM .R	MECH	/	/	/	/	/	/	/	/	/	/	/	/	/	/	/	/	/	/	/	/	/	/	/	/	/	/	/	/	/	/	/	/	/	/	/	/	/	/	/	/	/	/	/	/	/	/	/			
57																																																					
58																																																					
59																																																					
60																																																					
PRESENT																																																					
ABSENT																																																					
LEAVE																																																					

  
 PRINCIPAL,  
 K. S. R. INSTITUTE FOR  
 ENGINEERING AND TECHNOLOGY,  
 K. S. R. KALVI NAGAR,  
 TIRUCHENGODE - 637 215,  
 NAMAKKAL DISTRICT, TAMIL NADU.

This is to inform all the HoDs and department Training and Placement coordinators that the Training Programmes Problem Solving and Programming in C for II year students for the academic year 2017 - 2018 have been scheduled. All the registered students should attend the Training Programme. If any student skips this Training Programme without proper permission from the respective HoDs, he / she will not be permitted for any further Training Programme and campus recruitment process. Proper Dress Code is mandatory.

**Second year Training Schedule (Batch 2016 - 2020)**

S.No	Department	Topics	Dates Planned for Training	No of Days
1	CSE & MECH	Problem Solving and Programming in C	Every Monday from July 2017 to September 2017	9
2	IT, ECE & EEE		Every Friday from July 2017 to September 2017	10

Session Timing: 11am to 12.40 am

  
T&P OFFICER  
28/6/17

  
T&P COORDINATOR  
28/6/17

  
PRINCIPAL  
28/6/17

Copy to:

1. All HoDs
2. Notice Board

  
PRINCIPAL,  
K. S. R. INSTITUTE FOR  
ENGINEERING AND TECHNOLOGY,  
K. S. R. KALVI NAGAR,  
TIRUCHENGODE - 637 215,  
NAMAKKAL DL, TAMIL NADU.

Over all Coordinators:		Mr. M Jaganathan, Assistant Professor / CSE & Mr. R.Naresh, Assistant Professor / IT			
Virtual Lab Sessions--VLS					
S.No	Date/Day	Session No.	Topics	Time	
1	30.06.2017/Friday	3EB-VLS-PS-1	Input Output Statements and Operators	09:55 a.m to 12:40 p.m	
2	07.07.2017/Friday	3EB-VLS-PS-1	Input Output Statements and Operators	11:00 a.m to 12:40 p.m	
3	14.07.2017/Friday	3EB-VLS-PS-2	Conditional Statements	11:00 a.m to 12:40 p.m	
4	21.07.2017/Friday	3EB-VLS-PS-2	Conditional Statements	11:00 a.m to 12:40 p.m	
5	28.07.2017/Friday	3EB-VLS-PS-3	Looping Constructs I	11:00 a.m to 12:40 p.m	
6	04.08.2017/Friday	3EB-VLS-PS-3	Looping Constructs I	11:00 a.m to 12:40 p.m	
7	11.08.2017/Friday	3EB-VLS-PS-4	Looping Constructs II	11:00 a.m to 12:40 p.m	
8	18.07.2017/Friday	3EB-VLS-PS-4	Looping Constructs II	11:00 a.m to 12:40 p.m	
9	01.09.2017/Friday	3EB-VLS-PS-5	Functions and Pointers	11:00 a.m to 12:40 p.m	
10	08.09.2017/Friday	3EB-VLS-PS-5	Functions and Pointers	11:00 a.m to 12:40 p.m	

Venue: ECE - DSP/VLSI LAB(77), EEE - LANGUAGE LAB(46), IT - IT LAB(33)

Principals  
 29.06.17  
 T & P Officer

PRINCIPAL  
 K. S. R. INSTITUTE FOR  
 ENGINEERING AND TECHNOLOGY,  
 K. S. P. PALVINAGAR,  
 TIRUCHENGODE - 637 215,  
 NAMAKKAL DISTRICT, TAMIL NADU.

T&P Coordinator  
 27/6/17

Principal

S. No	Reg No	Name	Branch
1	731616106001	ABDULKADHAR S	ECE-A
2	731616106003	ADHITHYA KUMAR M	ECE-A
3	731616106005	AKSHAYA N M	ECE-A
4	731616106007	ANANTHA KRISHNAN P	ECE-A
5	731616106008	ARULIEESWARAN R	ECE-A
6	731616106009	ASHWIN S	ECE-A
7	731616106010	BALAJI R	ECE-A
8	731616106011	BHAVYA D	ECE-A
9	731616106012	BHAYASHREE S	ECE-A
10	731616106013	BHUVANESHWARI P	ECE-A
11	731616106014	BRAHADEESHWARAN M	ECE-A
12	731616106015	BRINDHA M	ECE-A
13	731616106016	DANATHARSHINI G	ECE-A
14	731616106017	DHARANI V	ECE-A
15	731616106018	DHIVYA T	ECE-A
16	731616106019	DINESH KRISHNA S	ECE-A
17	731616106020	DIVYA T	ECE-A
18	731616106021	DURAIRAJ S	ECE-A
19	731616106022	ELANGO VAN V	ECE-A
20	731616106023	GOKULA KRISHNAN A	ECE-A
21	731616106024	GOWTHAM M	ECE-A
22	731616106026	ILAKIYA S	ECE-A
23	731616106027	INDIRAKUMAR M	ECE-A
24	731616106028	ISWARYA P	ECE-A
25	731616106029	JAYASHRI M	ECE-A
26	731616106030	KAJAPATHY V	ECE-A
27	731616106031	KANIMOZHI R	ECE-A
28	731616106032	KARTHIKEYAN S	ECE-A
29	731616106033	KARTHIKEYAN V	ECE-A
30	731616106034	KOKILA K	ECE-A
31	731616106036	LOGESH KUMAR K	ECE-A
32	731616106037	MAHESWARAN J	ECE-A
33	731616106038	MALATHI A.S	ECE-A
34	731616106039	MARIMUTHU M	ECE-A
35	731616106040	MEENA A	ECE-A
36	731616106041	MEKALAI K	ECE-A
37	731616106042	MONIKA R	ECE-A
38	731616106044	NANDHAKUMAR M	ECE-B
39	731616106045	NANDHAKUMAR P	ECE-B
40	731616106046	NANDHAKUMARAN R	ECE-B
41	731616106047	NARESHKUMAR S	ECE-B
42	731616106048	NAVEEN K	ECE-B
43	731616106049	NIVETHA S	ECE-B
44	731616106050	NIVETHA T	ECE-B



S. No	Reg No	Name	Branch
1	731616205001	AHAMED FAISHAL H	IT
2	731616205002	AJITH KUMAR M	IT
3	731616205003	ARAVINDH K	IT
4	731616205004	ARUN KUMAR A	IT
5	731616205006	BOOPALAN G	IT
6	731616205007	DEEPAN K	IT
7	731616205008	GOPI S	IT
8	731616205009	GOWRI D	IT
9	731616205010	GOWTHAM D	IT
10	731616205011	HAKKEM M	IT
11	731616205012	INDHUMATHI S	IT
12	731616205013	IYYAPPAN J	IT
13	731616205014	JANANI M	IT
14	731616205015	JANANI R	IT
15	731616205016	JANANI T	IT
16	731616205017	KARKULAZHI S	IT
17	731616205018	KARTHIKA M	IT
18	731616205019	KAUSALYA J	IT
19	731616205020	KIRUBAKARAN R	IT
20	731616205021	MANI BHARATHI G	IT
21	731616205022	MOHANKUMAR M	IT
22	731616205023	MOHANRAJ S	IT
23	731616205024	MOUNIKA S	IT
24	731616205025	NESHAK KUMAR S	IT
25	731616205026	OVIYA A	IT
26	731616205027	PRATHAP KUMAR E	IT
27	731616205028	PRIYADARSHNI G	IT
28	731616205029	SAKTHIRAVIKUMAR M	IT
29	731616205030	SAM MCKENZIE R	IT
30	731616205031	SARASWATHY K	IT
31	731616205032	SATHAMHUSSAIN M S	IT
32	731616205033	SATHAS R	IT
33	731616205034	STEPHEN V	IT
34	731616205035	STEPHENRAJ J	IT
35	731616205036	SUDARSAN S	IT
36	731616205037	SUGITHA S	IT
37	731616205038	SUMITHA J	IT
38	731616205039	SWETHA S	IT
39	731616205040	TAMILARASAN G	IT
40	731616205041	VIGNESH M	IT
41	731616205042	VIJI V	IT
42	731616205043	VINOTH M	IT
43	731616205044	YAKSHEETHA V	IT
44	731616205045	YUVAPRIYA R	IT

## Training and Placement Cell

## E BOX Technical Training students Name list of CSE

BATCH : 2016 - 2020

Academic Year : 2017 - 2018

S. No	Reg No	Name	Branch
1	731616104001	AJITH KUMAR.P	CSE
2	731616104002	AKILAN.Y	CSE
3	731616104003	ANISHA.N	CSE
4	731616104004	ARUN.R	CSE
5	731616104005	BARATH.K	CSE
6	731616104006	DEEPAK SURIYA.A	CSE
7	731616104007	DEVADHARSHINI.S.S.	CSE
8	731616104008	DEVI GAYATHRI.S	CSE
9	731616104009	DHARANI.K	CSE
10	731616104010	GOWRI.S	CSE
11	731616104011	GOWTHAMAKUMARAN.P	CSE
12	731616104012	HARINI.R	CSE
13	731616104013	ILAKIYA.S	CSE
14	731616104014	INDHU.R	CSE
15	731616104015	INDIRA PRIYADHARSHINI.P	CSE
16	731616104016	JAYAVARSHINI.G	CSE
17	731616104017	JEEVITHA.R	CSE
18	731616104018	KAMALESH.M	CSE
19	731616104019	LAXMANCIBI.S	CSE
20	731616104020	MANIKANDAN.K	CSE
21	731616104021	MANJULA.R	CSE
22	731616104022	MEGASURIYAN.E	CSE
23	731616104023	MOHAMMEDSAMIRA.A	CSE
24	731616104024	NATHISH KUMARA.A	CSE
25	731616104025	NIVETHITHA.N	CSE
26	731616104026	PAVITHIRAN.S	CSE
27	731616104027	PRAVEENKUMAR.M	CSE
28	731616104028	PREMNATH.R	CSE
29	731616104030	PRIYANKA.V	CSE
30	731616104031	PUGAZHIVELAN.P	CSE
31	731616104032	PUJAA.V	CSE
32	731616104033	RAJARAJAN.A	CSE
33	731616104034	SELVAMALINI.J	CSE
34	731616104035	SHILPA.B	CSE
35	731616104036	SOUNDHARYA.A	CSE
36	731616104037	SRUTHI.S	CSE
37	731616104038	STELINBERCIA.S	CSE
38	731616104039	SUBHASREE.S	CSE
39	731616104040	SWETHA.B	CSE
40	731616104041	SWETHA.C	CSE
41	731616104042	VASU MITHA.R.S	CSE
42	731616104043	VELU PRABHA.S	CSE
43	731616104044	VENKATESH.M	CSE
44	731616104045	VENMATHI.S	CSE
45	731616104046	VIGNESH.G	CSE
46	731616104047	VISVESWARAN.B	CSE
47	731616104048	YUVAPRIYANKA.V	CSE

## E BOX Technical Training students Name list of EEE

BATCH : 2016 - 2020

Academic Year : 2017 - 2018

S. No	Reg No	Name	Branch
1	731616105002	AJITHA.P	EEE
2	731616105005	ARAVIND.R	EEE
3	731616105006	BHARATH.S	EEE
4	731616105007	BHARATHI KANNAN.M.R	EEE
5	731616105008	BOOPATHI.M	EEE
6	731616105010	DIVYADEVI.V	EEE
7	731616105011	GANESHBABU.V	EEE
8	731616105012	INIYADHARINI.R	EEE
9	731616105014	JEEVA.M	EEE
10	731616105015	JEEVA.R	EEE
11	731616105017	KANIMOZHI.V	EEE
12	731616105018	KARTHIKA DEVI.S	EEE
13	731616105019	KAVINKUMAR.K	EEE
14	731616105020	KAVIYA.M	EEE
15	731616105022	LOGESHWARAN.V	EEE
16	731616105023	MADHUMITHA.J.S	EEE
18	731616105024	MANOJKUMAR.V	EEE
19	731616105025	MADHUBALAN.S	EEE
20	731616105026	MERLIN INFANTA	EEE
21	731616105027	MOHANRAJ.S	EEE
22	731616105029	MUGESH.M	EEE
23	731616105030	MYTHILI.N	EEE
24	731616105031	NANCY ASMITHA.P.A	EEE
25	731616105032	NANDHINI.M	EEE
26	731616105033	NAVANEETHAN.S	EEE
27	731616105034	NITHIYASRI.R	EEE
28	731616105035	PIREETHIA	EEE
29	731616105036	PRAKASH.S.P	EEE
30	731616105037	PRAVEEN.D	EEE
31	731616105038	PRAVIN.R	EEE
32	731616105039	PREETHA.E	EEE
33	731616105040	PREMKUMAR.G	EEE
34	731616105041	SARANYA.P	EEE
35	731616105042	SARAVANAN.V	EEE
36	731616105043	SHANKAR NARAYAN.M	EEE
37	731616105044	SIBIN.S	EEE
38	731616105045	SUJITHA.E	EEE
39	731616105046	SUVETHA.T	EEE
40	731616105047	VIVEK.V	EEE

## E BOX Technical Training students Name list of MECH

BATCH : 2016 - 2020

Academic Year : 2017 - 2018

S. No	Reg No	Name	Branch
1	731616114001	AAKASH S	MECH A
2	731616114003	ANNAMALAI K	MECH A
3	731616114004	ARSHATH S	MECH A
4	731616114005	ASWINKUMAR S	MECH A
5	731616114006	BHARATH V	MECH A
6	731616114009	CHANDRASEKAR K	MECH A
7	731616114011	DEEPAK R	MECH A
8	731616114012	DHAYANIDHI M	MECH A
9	731616114013	DHEVENDRAN E	MECH A
10	731616114014	DHINAKARAN P	MECH A
11	731616114015	DINESH KUMAR C	MECH A
12	731616114016	GOKUL R	MECH A
13	731616114017	GOKULRAJ P	MECH A
14	731616114018	GOPINATH G	MECH A
15	731616114019	GOVINDASAMY.A	MECH A
16	731616114020	GOWTHAM P	MECH A
17	731616114021	GUNASEKARAN R	MECH A
18	731616114022	HARIHARAN M	MECH A
19	731616114023	HARIHARAN S	MECH A
20	731616114024	HARI SHANKAR P	MECH A
21	731616114025	INBARASAN C	MECH A
22	731616114027	JAYAMURUGAN K S	MECH A
23	731616114028	JEEVA K	MECH A
24	731616114029	JEEVA M	MECH A
25	731616114030	JESTINRAJ K	MECH A
26	731616114031	JOSHUA Y	MECH A
27	731616114032	KALEESWARAN D	MECH A
28	731616114033	KAROLE INFANTO D	MECH A
29	731616114034	KARTHIKEYAN P	MECH A
30	731616114035	KAVIN P	MECH A
31	731616114037	KEERTHIVASAN.S	MECH A
32	731616114038	KESAV GOUTHAM N B	MECH A
33	731616114039	KEVIN SEBASTIN R	MECH A
34	731616114040	KIRUBAKARAN M	MECH A
35	731616114042	LOGESH N	MECH A
36	731616114043	LOGESH S	MECH A
37	731616114044	MADHANKUMAR L	MECH A
38	731616114045	MAGESWARAN A	MECH A
39	731616114046	MANIKANDAN V	MECH A
40	731616114048	MOHAMMED NIHAL R	MECH A
41	731616114049	MOHANA KRISHNAN D	MECH A
42	731616114052	NAMBIRAJ J	MECH B

S. No	Reg No	Name	Branch
43	731616114053	NANDHAGOBAL S	MECH B
44	731616114054	NAVINKUMAR M	MECH B
45	731616114055	PARTHASARATHY R	MECH B
46	731616114056	PRABAKARAN S	MECH B
47	731616114057	PRABHAKARAN M	MECH B
48	731616114058	PRASANTH R	MECH B
49	731616114059	PRAVEEN R (07.01.1999)	MECH B
50	731616114060	PRAVEEN R (31.03.1999)	MECH B
51	731616114062	PREMKUMAR K R	MECH B
52	731616114063	RAGAVENDHAR S	MECH B
53	731616114064	RAHUL C	MECH B
54	731616114065	RAJKUMAR S	MECH B
55	731616114067	RANJITHKUMAR R	MECH B
56	731616114068	RANJITH KUMAR V	MECH B
57	731616114069	RAVICHANDRAN S	MECH B
58	731616114071	RUTHRANNAN B	MECH B
59	731616114073	SAKTHI GNANASUNDARAM R H	MECH B
60	731616114074	SAKTHIVEL R	MECH B
61	731616114075	SANJAY KUMAR S	MECH B
62	731616114076	SANJAY KUMAR S K	MECH B
63	731616114077	SANTHOSH KUMAR B	MECH B
64	731616114078	SANTHOSH KUMAR V	MECH B
65	731616114079	SARAN K	MECH B
66	731616114080	SARANRAJ S	MECH B
67	731616114081	SATHISH G	MECH B
68	731616114082	SHAKTHI R M	MECH B
69	731616114083	SOWNDHAR A	MECH B
70	731616114084	SURYA R	MECH B
71	731616114085	TAMILMUGILAN N	MECH B
72	731616114086	THAMOTHARAN J	MECH B
73	731616114087	THIRUMURUGAN V	MECH B
74	731616114088	UTHAYA KUMAR M	MECH B
75	731616114089	VASANTH S	MECH B
76	731616114090	VASANTHAKUMAR P	MECH B
77	731616114091	VELMURUGAN T	MECH B
78	731616114092	VIGNESH B	MECH B
79	731616114093	VIGNESH V	MECH B
80	731616114094	VIJAY ANAND G	MECH B
81	731616114095	VIJAYARAGAVAM P	MECH B
82	731616114096	VINOTHMANI M	MECH B
83	731616114097	VISHNU A	MECH B
84	731616114098	VIVEK P	MECH B
85	731616114099	YOGARAJ G	MECH B
86	731616114100	YOGESH T	MECH B

PRINCIPAL,  
 K. S. R. INSTITUTE FOR  
 ENGINEERING AND TECHNOLOGY,  
 K. S. R. KALVI NAGAR,  
 TIRUCHENGODE - 637 215,  
 NAMAKKAL Dt, TAMIL NADU.



This is to inform all the HoDs and department Training and Placement coordinators that the Training Programmes on Programming in C (July) and Programming in Data Structures( August and September ) for III year students for the academic year 2017 - 2018 have been scheduled. All the registered students should attend the Training Programme. If any student skips this Training Programme without proper permission from the respective HoDs, he / she will not be permitted for any further Training Programme and campus recruitment process. Proper Dress Code is mandatory. The detailed schedule id attached.

  
T&P OFFICER

  
T&P COORDINATOR

  
PRINCIPAL

Copy to:

1. All HoDs
2. Notice Board

  
PRINCIPAL,  
K. S. R. INSTITUTE FOR  
ENGINEERING AND TECHNOLOGY,  
K. S. R. KALVI NAGAR,  
TIRUCHENGODE - 637 215,  
NAMAKKAL DI, TAMIL NADU.

K S ., INSTITUTE FOR ENGINEERING AND TECHNOLOGY, TIRUCHENGODE - 637215

Training and Placement Cell

E Box - Programming Skill Enhancement Programme for Third Year students

Course: Problem Solving and Programming in C

Academic Year:2017-2018

Batch:2015-2019

Over all Coordinators: Mr. M Jaganathan, Assistant Professor / CSE & Mr. R.Naresh, Assistant Professor / IT

S.No.	Date/Day	Session No.	Topics	Time
Virtual Lab Sessions--VLS				
S.No	Date/Day	Session No.	Topics	Time
1	03.07.2017/Monday	3EB-VLS-PS-1	Input Output Statements and Operators	01:45 p.m to 06:30 p.m
2	06.07.2017/Thursday	3EB-VLS-PS-2	Conditional Statements	04:30 p.m to 06:30 p.m
3	08.07.2017/Saturday	3EB-VLS-PS-3,4	Looping Constructs I, Looping Constructs II	09:00 a.m to 04:30 p.m
4	10.07.2017/Monday	3EB-VLS-PS-5	Functions and Pointers	01:45 p.m to 06:30 p.m
5	13.07.2017/Thursday	3EB-VLS-PS-6	1-D Arrays	04:30 p.m to 06:30 p.m
6	15.07.2017/Saturday	3EB-VLS-PS-7	2-D Arrays	09:00 a.m to 04:30 p.m
7	17.07.2017/Monday	3EB-VLS-PS-8	Strings	01:45 p.m to 06:30 p.m
8	20.07.2017/Thursday	3EB-VLS-PS-9	Recursion	04:30 p.m to 06:30 p.m
9	22.07.2017/Saturday	3EB-VLS-PS-9	Recursion	09:00 a.m to 04:30 p.m
10	29.07.2017/Saturday	3EB-VLS-PS-10	Structures	09:00 a.m to 04:30 p.m
Code Challenges-CC				
S.No.	Date/Day	Session No.	Topics	Time
11	31.07.2017/Monday	3EB-CC-PS-1	Control Constructs	01:45 p.m to 06:30 p.m
12	05.08.2017/Saturday	3EB-CC-PS-2	Arrays	09:30 p.m to 12:30 p.m
13	05.08.2017/Saturday	3EB-CC-PS-3	Strings and Recursion	01:30 p.m to 04:30 p.m

*Prasad*  
23.07.17  
T & P Officer

*[Signature]*  
T&P Coordinator

*[Signature]*

Principal

PRINCIPAL,  
K. S. R. INSTITUTE FOR  
ENGINEERING AND TECHNOLOGY,  
K. S. R. KALAI MAGAR,  
TIRUCHENGODE - 637 215,  
NAMAKKAL DISTRICT, TAMIL NADU.

K.S.K. INSTITUTE FOR ENGINEERING AND TECHNOLOGY, TIRUCHENGODE - 637215

Training and Placement Cell

E Box - Programming Skill Enhancement Programme for Third Year Students

Course: Data Structures

Academic Year:2017-2018

Batch:2015-2019

Over all Coordinators: Mr. M.Jaganathan Assistant Professor / CSE & Mr. R.Nareesh Assistant Professor / IT

Academic Year:2016-2017

Batch:2015-2019

Trainer Led Sessions--TLS			
S.No.	Date/Day	Session No.	Topics
1	07.08.2017/Monday	3EB-TLS-DS-1	Linked list,Stack,Queue
2	08.08.2017/Tuesday	3EB-TLS-DS-2	Trees
3	09.08.2017/Wednesday	3EB-TLS-DS-3	Graphs
			Time
			09:00 A.M to 06:30 P.M
			09:00 A.M to 06:30 P.M
			09:00 A.M to 06:30 P.M

Virtual Lab Sessions--VLS			
S.No.	Date/Day	Session No.	Topics
4	10.08.2017/Thursday	3EB-VLS-DS-1	Linked list
5	17.08.2017/Thursday	3EB-VLS-DS-2,3	Doubly Linked List,Stacks and its
6	24.08.2017/Thursday	3EB-VLS-DS-4	Queue and its Applications
7	28.08.2017/Monday	3EB-VLS-DS-5	Trees
8	31.08.2017/Thursday	3EB-VLS-DS-5,6	Trees,BST
9	04.09.2017/Monday	3EB-VLS-DS-7	Heaps
10	07.09.2017/Thursday	3EB-VLS-DS-8	Graphs
			Time
			04:30 P.m to 06:30 P.M
			04:30 P.M to 06:30 P.M
			01:45 P.M to 06:30 P.M
			01:45 P.M to 06:30 P.M
			04:30 P.M to 06:30 P.M
Code Challenges--CC			
11	09.09.2017/Saturday	3EB-CC-DS-1	Problem Solving
12	09.09.2017/Saturday	3EB-CC-DS-2	Linear Data Structures
13	11.09.2017/Monday	3EB-CC-DS-3	Non Linear Datastructures
			Time
			09:30 A.M to 12:30 P.M
			01:30 P.M to 04:30 P.M
			01:45 P.M to 06:30 P.M

Principals  
08/09/2017  
T & P Officer

T&P Coordinator

Principal

Principal

K.S.K. INSTITUTE FOR  
ENGINEERING AND TECHNOLOGY,  
K. S. R. KALVI NAGAR,  
TIRUCHENGODE - 637 215,  
NAMAKKAL Dt, TAMIL NADU.



S. No	Reg No	Name	Branch
1	731615105046	LOHESH J	EEE B
2	731615105049	MAHAESWARI A	EEE B
3	731615105053	MOHAMMEDRIYAS A	EEE B
4	731615105055	MONISHA V	EEE B
5	731615105057	MURUGANANTH M	EEE B
6	731615105058	NAVEEN M T	EEE B
7	731615105059	NAVEEN KUMAR S	EEE B
8	731615105060	PAVITHRA M	EEE B
9	731615105062	POOJA R	EEE B
10	731615105065	PRIYADHARSHINI S	EEE B
11	731615105066	RAJASEKAR P V	EEE B
12	731615105067	RAMESH S R	EEE B
13	731615105071	SATHISH KUMAR M	EEE B
14	731615105072	SEKAR S	EEE B
15	731615105073	SOUNDHARYA S	EEE B
16	731615105075	SRINITHI G	EEE B
17	731615105076	SRINIVASAN R	EEE B
18	731615105077	STEPHEN IMMANUVEL J	EEE B
19	731615105079	SWATHI R	EEE B
20	731615105085	VISHNU R	EEE B
21	731615105086	YOGAPRIYA S	EEE B
22	731615105087	YOGESHWARAN S	EEE B
23	731615105002	ARUNKUMAR C	EEE A
24	731615105005	CHIDAMBARAM V	EEE A
25	731615105007	DHIVAGAR N	EEE A
26	731615105008	DHIVAGAR S	EEE A
27	731615105011	ELANCHEZHIAN P	EEE A
28	731615105012	GAYATHRI K	EEE A
29	731615105021	GOWSALYA A	EEE A
30	731615105024	GOWTHAM V	EEE A
31	731615105026	HARIHARAN G	EEE A
32	731615105029	HARINI S	EEE A
33	731615105030	JANANI R	EEE A
34	731615105033	JEEVAPRAKASH V	EEE A
35	731615105034	KALAICHELVI V	EEE A
36	731615105035	KANNAN S	EEE A
37	731615105039	KEERTHIKA C	EEE A
38	731615105041	KODEESWARI M	EEE A
39	731615105042	KOKILAVANI M	EEE A
40	731615105044	KRISHNAMOORTHY S	EEE A

S. No	Reg No	Name	Branch
1	731615106002	ANBARASAN.S	ECE - A
2	731615106003	ARUNKUMARA	ECE - A
3	731615106005	BALAJI.S	ECE - A
4	731615106006	BHARATHI.D	ECE - A
5	731615106007	BHUVANESWARAN.S.M	ECE - A
6	731615106009	BHUVANESWARI.R	ECE - A
7	731615106010	CHANDRA BOSE.S	ECE - A
8	731615106012	DEVI.U	ECE - A
9	731615106013	DHARAN.I.R	ECE - A
10	731615106014	DHAYALI.G	ECE - A
11	731615106015	DHIVYA.M	ECE - A
12	731615106016	DIVYA.S	ECE - A
13	731615106017	DIVYA.S	ECE - A
14	731615106018	EZHILM	ECE - A
15	731615106021	GIRITHARAN.L	ECE - A
16	731615106022	GOKILA.T	ECE - A
17	731615106023	GOPALAKRISHNAN.R	ECE - A
18	731615106024	GOWRI.P	ECE - A
19	731615106025	HARINI.T	ECE - A
20	731615106026	HARSHINI DEVI.P	ECE - A
21	731615106027	HEMALATHA.T	ECE - A
22	731615106029	JAYABHARATHI.S	ECE - A
23	731615106031	KALAISELVAN.G	ECE - A
24	731615106032	KARTHIKA.D	ECE - A
25	731615106034	KARTHIKEYAN.S	ECE - A
26	731615106036	KAVIPREETHI.V	ECE - A
27	731615106037	KEERTHANA.L	ECE - A
28	731615106039	KOKILA.R	ECE - A
29	731615106041	KOWSALYA.C	ECE - A
30	731615106303	RAMKUMAR L	ECE - A
31	731615106039	KEERTHANA S	ECE - B
32	731615106042	LOGAPRIYA M	ECE - B
33	731615106046	NAVEEN T S	ECE - B
34	731615106049	NIVETHA K	ECE - B
35	731615106050	NIVETHAN RAJ C	ECE - B
36	731615106053	PAVITHRA R	ECE - B
37	731615106054	PAVITHRA P	ECE - B
38	731615106057	PRAVEENKUMAR V	ECE - B
39	731615106059	PRIYADHARSHINI S	ECE - B
40	731615106061	PRIYANGA S	ECE - B
41	731615106063	RAMYA B	ECE - B
42	731615106064	RANJITHRAJA M	ECE - B
43	731615106065	SAKTHIVEL K	ECE - B
44	731615106066	SARANYA M	ECE - B
45	731615106067	SARASWATHI P	ECE - B

S. No	Reg No	Name	Branch
46	731615106068	SARAVANAKUMAR R	ECE - B
47	731615106069	SELVARAKESHKUMAR C	ECE - B
48	731615106070	SOWMIYA C	ECE - B
49	731615106071	SRIDHAR C	ECE - B
50	731615106072	SRIDHARAN S	ECE - B
51	731615106073	SUGANTHI S	ECE - B
52	731615106074	TAMILARASI J	ECE - B
53	731615106076	THARUNYA S	ECE - B
54	731615106077	UMA MAHESHWARI M	ECE - B
55	731615106078	VINAY V	ECE - B
56	731615106079	VINOTHINI G	ECE - B
57	731615106080	VINOTHKUMA M	ECE - B
58	731615106701	MAHESWARI C	ECE - B

  
PRINCIPAL,  
K. S. R. INSTITUTE FOR  
ENGINEERING AND TECHNOLOGY,  
K. S. R. KALMI NAGAR,  
TIRUCHENGODE - 637 215,  
NAMAKKAL Dt, TAMIL NADU.

S. No	Reg No	Name	Branch
1	731615104001	AARTHI R	CSE
2	731615104002	AJITH KUMAR P	CSE
3	731615104005	BALAJI M	CSE
4	731615104007	BOOPATHIRAJA M	CSE
5	731615104008	DINESH J	CSE
6	731615104009	ELAKKIYA T.E	CSE
7	731615104010	GOKUL K	CSE
8	731615104012	GUNA BHARATHI T	CSE
9	731615104016	KIRUBHANANDHAN P	CSE
10	731615104017	MANIKANDAN S	CSE
11	731615104018	MEIYEAPPAN M	CSE
12	731615104019	MOHANRAJ C	CSE
13	731615104020	MUNUSAMY R	CSE
14	731615104021	NAVEENA D	CSE
15	731615104023	NISHA S	CSE
16	731615104024	PAVITHRA A	CSE
17	731615104025	PAVITHRA E	CSE
18	731615104026	PRADEEPKUMAR R	CSE
19	731615104027	PRASANTH RAJA (10/06/1997)	CSE
20	731615104029	PRAVEEN G	CSE
21	731615104030	PRIYADHARSHINI R	CSE
22	731615104031	RAJAGANAPATHY T	CSE
23	731615104032	SABANA YASMINE A	CSE
24	731615104033	SAKTHIVEL E	CSE
25	731615104034	SARANYA S	CSE
26	731615104036	SHALINI S	CSE
27	731615104037	SHARTHAJ BANU D	CSE
28	731615104038	SIVA SAKTHIVEL P	CSE
29	731615104044	VINOTHA V	CSE
30	731615104701	KAVIN D	CSE
31	731615205001	ABHITH JOHN ANTO.K	IT
32	731615205002	AISWARYA.R	IT
33	731615205005	ARAVIND KUMAR.V	IT
34	731615205006	ARUNKUMAR.R	IT
35	731615205008	BALAJI.S	IT
36	731615205011	DENMOZHIS	IT
37	731615205012	DHANUSYADEVI.S	IT
38	731615205014	DHARANIP	IT
39	731615205016	DIVYA.R	IT
40	731615205017	ELANGOVAN.P	IT
41	731615205018	ELANGOVAN.S	IT
42	731615205019	ELANKANELM	IT
43	731615205021	GOWSIKKANNAN.V	IT
44	731615205022	GOWTHAM.R	IT
45	731615205023	HEMALATHA.G	IT
46	731615205026	MANOJKUMAR.D	IT
47	731615205029	PRIYANKA.S	IT

S. No	Reg No	Name	Branch
48	731615205031	RAMESH.A	IT
49	731615205035	RINESH.R	IT
50	731615205036	SARAVANAPRIYA R	IT
51	731615205037	SELVAKUMAR.B	IT
52	731615205038	SNEKA D	IT
53	731615205039	SUNDARAMOORTHI.G	IT
54	731615205040	THIRUMALAIRAJAN.K	IT
55	731615205042	VINEETH PRAVEEN V	IT



PRINCIPAL,  
K. S. R. INSTITUTE FOR  
ENGINEERING AND TECHNOLOGY,  
K. S. R. KALVINAGAR,  
TIRUCHENGODE - 637 215,  
NAMAKKAL DI, TAMIL NADU.

## Training and Placement Cell

## E BOX Technical Training students Name list of MECH

BATCH : 2015 - 2019

Academic Year : 2017 - 2018

S. No	Reg No	Name	Branch
1	731615114001	ADHISHANKARAN D	MECH - A
2	731615114009	ARAVINTHAN P V	MECH - A
3	731615114025	CELLAKAMALALAKSHMI R	MECH - A
4	731615114038	DINESHKUMAR T	MECH - A
5	731615114057	JAGADEESHBABU K	MECH - A
6	731615114098	NISHANTHI B	MECH - A
7	731615114066	KAVIPRIYAN S	MECH - B
8	731615114067	KESAVARAJ M	MECH - B
9	731615114077	MANIKANDAN P	MECH - B
10	731615114080	MANOJKUMAR P R	MECH - B
11	731615114083	MOHAN KUMAR R	MECH - B
12	731615114120	SANTHOSH K	MECH - C
13	731615114121	SANTHOSHKUMAR S	MECH - C
14	731615114123	SANTHOSH KUMAR R	MECH - C
15	731615114146	SURYA S C	MECH - C
16	731615114158	VIGNESH M	MECH - C
17	731615114162	VIJAY P	MECH - C
18	731615114313	NAVEEN A	MECH - C
19	731615114316	PRAVINTH .K	MECH - C
20	731615114318	RANJITHKUMAR .M	MECH - C

PRINCIPAL,  
K. S. R. INSTITUTE FOR  
ENGINEERING AND TECHNOLOGY,  
K. S. R. KALVI NAGAR,  
TIRUCHENGODE - 637 215,  
NAMAKKAL Dt, TAMIL NADU.



Ref: KSRIET/T&P/CIR/2017-18

Date: 28.11.2017

This is to inform all the HoDs and department Training and Placement coordinators that the Training Programmes on Data Structures for III year students for the academic year 2017 - 2018 have been scheduled. All the registered students should attend the Training Programme. If any student skips this Training Programme without proper permission from the respective HoDs, he / she will not be permitted for any further Training Programme and campus recruitment process. Proper Dress Code is mandatory. The detailed schedule is attached.

  
T&P OFFICER

  
T&P COORDINATOR

  
PRINCIPAL

Copy to:

1. All HoDs
2. Notice Board

  
PRINCIPAL,  
K. S. R. INSTITUTE FOR  
ENGINEERING AND TECHNOLOGY,  
K. S. R. KALVI NAGAR,  
TIRUCHENGODE - 637 215,  
NAMAKKAL Dt, TAMIL NADU.

**KSR INSTITUTE FOR ENGINEERING AND TECHNOLOGY, TIRUCHENGODE - 637215**  
**Training and Placement Cell**

**E Box - Programming Skill Enhancement Programme for Third Year Students**  
**Course: Data Structures**

**Academic Year:2017-2018**

**Batch:2015-2019**

**III Year Technical Training Programme Schedule**

Date	09.00 AM TO 09.45 AM	09.45 AM TO 10.30 AM	10.45 AM TO 11.30 AM	11.30 AM TO 12.30 PM	01.15 PM TO 04.15 PM
<b>Programming in C Language</b>					
04.12.2017	Conditional / Looping Statements, Switch, Break & Continue Statement	Arrays, Multidimensional Arrays, String, Matrix Operations	Functions	Introduction to Pointers	Lab Based on Skill Rack Tools
05.12.2017	Pointers	Pointers and Arrays	Structures & Unions	Storage Class, Dynamic Memory Allocation	
<b>Data Structure</b>					
06.12.2017	Linked List	Doubly Linked List	Circular Linked List		Lab Based on Skill Rack Tools
07.12.2017	Stack		Queue		
08.12.2017	Trees		Binary search Tree		

**Venue:**

Batch	Branch & Strength	Hall No	
		FN	AN
Batch - I	CSE (31)&IT(26)	101	CSE Lab - I
Batch - II	EEE (39)	104	IT Lab
Batch - III	ECE(57)	102	Language Lab

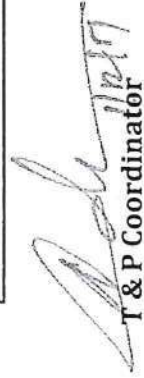
  
**T & P Coordinator**

  
**PRINCIPAL,**  
**K. S. R. INSTITUTE FOR**  
**ENGINEERING AND TECHNOLOGY,**  
**K. S. R. KALVI NAGAR,**  
**TIRUCHENGODE - 637 215,**  
**NAMAKKAL DC, TAMIL NADU.**



**Training and Placement Cell - CSE & IT**  
**E Box Internal C & Data Structure Training Attendance**

**BATCH : 2015 - 2019**

**Academic Year: 2017 - 2018**

S. No	Reg No	Name	Branch	4.12.17		5.12.17		6.12.17		7.12.17		8.12.17	
				FN	AN	FN	AN	FN	AN	FN	AN	FN	AN
1	731615104001	AARTHI R	CSE	/	/	/	/	/	/	/	/	/	/
2	731615104002	AJITH KUMAR P	CSE	P	P	a	a	a	a	a	a	/	/
3	731615104005	BALAJI M	CSE	/	/	/	/	/	/	/	/	/	/
4	731615104007	BOOPATHIRAJA M	CSE	P	P	a	a	a	a	/	/	/	/
5	731615104008	DINESH J	CSE	/	/	/	/	/	/	/		a	a
6	731615104009	ELAKKIYA T.E	CSE	a	a	/	/	/	/	a	a	/	/
7	731615104010	GOKUL K	CSE	/	/	a	a	/	/	/	/	/	/
8	731615104012	GUNA BHARATHI T	CSE	P	P	P	P	/	/	/	/	a	a
9	731615104016	KIRUBHANANDHAN P	CSE	/	/	/	/	a	a	/	/	/	/
10	731615104017	MANIKANDAN S	CSE	a	a	/	/	/	/	a	a	a	a
11	731615104018	MEIYEAPPAN M	CSE	/	/	a	a	/	/	/	/	/	/
12	731615104019	MOHANRAJ C	CSE	/	/	/	/	a	a	a	a	/	/
13	731615104020	MUNUSAMY R	CSE	P	P	P	P	/	/	/	/	/	/
14	731615104021	NAVEENA D	CSE	P	P	/	/	/	/	/	/	/	/
15	731615104023	NISHA S	CSE	/	/	/	/	/	/	P	P	a	a
16	731615104024	PAVITHRA A	CSE	a	a	a	a	/	/	/	/	/	/
17	731615104025	PAVITHRA E	CSE	/	/	/	/	a	a	/	/	/	/
18	731615104026	PRADEEPKUMAR R	CSE	P	P	a	a	/	/	a	a	/	/
19	731615104027	PRASANTH RAJA (10/06/	CSE	/	/	/	/	/	/	/	/	/	/
20	731615104029	PRAVEEN G	CSE	/	/	P	P	/	/	a	a	/	/
21	731615104030	PRIYADHARSHINI R	CSE	/	/	/	/	a	a	/	/	/	/
22	731615104031	RAJAGANAPATHY T	CSE	a	a	/	/	/	/	a	a	/	/
23	731615104032	SABANA YASMINE A	CSE	/	/	/	/	a	a	/	/	/	/
24	731615104033	SAKTHIVEL E	CSE	/	/	/	/	/	/	/	/	a	a
25	731615104034	SARANYA S	CSE	P	P	/	/	a	a	/	/	/	/
26	731615104036	SHALINI S	CSE	/	/	a	a	/	/	/	/	a	a
27	731615104037	SHARTHAJ BANU D	CSE	/	/	/	/	/	/	a	a	/	/
28	731615104038	SIVA SAKTHIVEL P	CSE	a	a	a	a	/	/	/	/	/	/
29	731615104044	VINOTHA V	CSE	/	/	/	/	a	a	a	a	/	/
30	731615104701	KAVIN D	CSE	/	/	/	/	a	a	/	/	/	/
31	731615205001	ABHITH JOHN ANTO.K	IT	/	/	/	/	P	P	/	/	/	/
32	731615205002	AISWARYA.R	IT	a	a	/	/	/	/	/	/	/	/
33	731615205005	ARAVIND KUMAR.V	IT	/	/	/	/	/	/	/	/	/	/
34	731615205006	ARUNKUMAR.R	IT	P	P	/	/	/	/	a	a	/	/
35	731615205008	BALAJI.S	IT	/	/	/	/	/	/	/	/	/	/
36	731615205011	DENMOZHIS	IT	/	/	/	/	a	a	/	/	/	/
37	731615205012	DHANUSYADEVIS	IT	P	P	/	/	/	/	/	/	/	/

PRINCIPAL,  
 K. S. R. INSTITUTE FOR  
 ENGINEERING AND TECHNOLOGY,  
 K. S. R. KALVI NAGAR,  
 TIRUCHENGODE - 637 215,  
 NANAKKAL DE, TAMIL NADU.

S. No	Reg No	Name	Branch	FN		AN		FN		AN		FN		AN	
				FN	AN	FN	AN	FN	AN	FN	AN	FN	AN		
38	731615205014	DHARANI.P	IT	1	1	1	1	1	1	1	1	1	1	1	1
39	731615205016	DIVYA.R	IT	P	P	1	1	1	1	A	A	1	1	1	1
40	731615205017	ELANGO.VAN.P	IT	1	1	1	1	1	1	1	1	1	1	1	1
41	731615205018	ELANGO.VAN.S	IT	1	1	1	1	A	A	1	1	1	1	1	1
42	731615205019	ELANKANEI.M	IT	1	1	A	A	1	1	1	1	1	1	1	1
43	731615205021	GOWSIKKANNAN.V	IT	1	1	1	1	1	1	1	1	1	1	1	1
44	731615205022	GOWTHAM.R	IT	1	1	1	1	1	1	1	1	1	1	1	1
45	731615205023	HEMALATHA.G	IT	1	1	P	P	1	1	1	1	1	1	1	1
46	731615205026	MANOJKUMAR.D	IT	1	1	1	1	1	1	1	1	1	A	A	1
47	731615205029	PRIYANKA.S	IT	P	P	1	1	A	A	1	1	1	1	1	1
48	731615205031	RAMESH.A	IT	A	A	1	1	1	1	1	1	1	1	1	1
49	731615205035	RINESH.R	IT	1	1	1	1	1	1	1	1	1	1	1	1
50	731615205036	SARAVANAPRIYA R	IT	1	1	A	A	1	1	1	1	1	1	1	1
51	731615205037	SELVAKUMAR.B	IT	A	A	1	1	1	1	P	P	1	1	1	1
52	731615205038	SNEKA D	IT	1	1	1	1	1	1	1	1	1	1	1	1
53	731615205039	SUNDARAMOORTHI.G	IT	P	P	1	1	A	A	1	1	1	1	1	1
54	731615205040	THIRUMALAIRAJAN.K	IT	1	1	1	1	1	1	1	1	1	1	1	1
55	731615205042	VINEETH PRAVEEN V	IT	1	1	1	1	1	1	1	1	1	1	A	A
<b>PRESENT</b>				35	35	39	39	41	42	41	44	47	47		
<b>ABSENT</b>				18	8	18	18	13	12	12	8	8	8		
<b>LEAVE</b>				12	12	24	24	1	1	2	3	0	0		
<b>NOT INTEREST</b>				0	0	0	0	0	0	0	0	0	0		

  
 PRINCIPAL,  
 K. S. R. INSTITUTE FOR  
 ENGINEERING AND TECHNOLOGY,  
 K. S. R. KALVI NAGAR,  
 TIRUCHENGODE - 637 215,  
 NAMAKKAL Dt, TAMIL NADU.

## Training and Placement Cell - ECE

## E Box Internal C &amp; Data Structure Training Attendance

BATCH : 2015 - 2019

Academic Year: 2017 - 2018

S. No	Reg No	Name	Branch	4.12.17		5.12.17		6.12.17		7.12.17		8.12.17	
				FN	AN	FN	AN	FN	AN	FN	AN	FN	AN
1	731615106002	ANBARASAN.S	ECE - A	/	/	/	/	/	/	/	/	/	/
2	731615106003	ARUNKUMARA	ECE - A	/	/	a	a	/	/	/	/	/	/
3	731615106005	BALAJI.S	ECE - A	/	/	/	/	/	/	a	a	/	/
4	731615106006	BHARATHI.D	ECE - A	/	/	/	/	/	/	/	/	/	/
5	731615106007	BHUVANESWARAN.S.M	ECE - A	/	/	/	/	a	a	/	/	/	/
6	731615106009	BHUVANESWARI.R	ECE - A	/	/	/	/	/	/	/	/	/	/
7	731615106010	CHANDRA BOSE.S	ECE - A	/	/	/	/	/	/	/	/	P	P
8	731615106012	DEVI.U	ECE - A	/	/	/	/	/	/	/	/	/	/
9	731615106013	DHARANI.R	ECE - A	P	/	/	/	/	/	/	/	/	/
10	731615106014	DHAYALI.G	ECE - A	/	/	/	/	/	/	P	P	/	/
11	731615106015	DHIVYAM	ECE - A	/	/	a	/	/	/	/	/	/	/
12	731615106016	DIVYA.S	ECE - A	/	/	/	/	/	/	/	/	/	/
13	731615106017	DIVYA.S	ECE - A	/	/	/	/	P	/	/	/	a	a
14	731615106018	EZHILM	ECE - A	/	/	/	/	/	/	/	/	/	/
15	731615106021	GIRITHARAN.L	ECE - A	/	/	/	/	/	/	/	/	/	/
16	731615106022	GOKILA.T	ECE - A	/	/	/	/	/	/	/	/	/	/
17	731615106023	GOPALAKRISHNAN.R	ECE - A	/	/	/	/	/	/	/	/	/	/
18	731615106024	GOWRI.P	ECE - A	/	/	/	/	/	/	/	/	/	/
19	731615106025	HARINI.T	ECE - A	/	/	/	/	/	/	/	/	/	/
20	731615106026	HARSHINI DEVI.P	ECE - A	/	/	/	/	/	/	/	/	/	/
21	731615106027	HEMALATHA.T	ECE - A	/	/	/	/	/	/	/	/	/	/
22	731615106029	JAYABHARATHI.S	ECE - A	/	/	/	/	/	/	/	/	/	/
23	731615106031	KALAISELVAN.G	ECE - A	/	/	/	/	/	/	/	/	/	/
24	731615106032	KARTHIKA.D	ECE - A	/	/	/	/	/	/	/	/	/	/
25	731615106034	KARTHIKEYAN.S	ECE - A	/	/	/	/	/	/	/	/	/	/
26	731615106036	KAVIPREETHI.V	ECE - A	/	/	/	/	/	/	/	/	/	/
27	731615106037	KEERTHANA.L	ECE - A	/	/	/	/	/	/	/	/	/	/
28	731615106039	KOKILA.R	ECE - A	/	/	/	/	/	/	/	/	/	/
29	731615106041	KOWSALYA.C	ECE - A	/	/	/	/	/	/	/	/	/	/
30	731615106303	RAMKUMAR L	ECE - A	/	/	P	P	/	/	/	/	/	/
31	731615106039	KEERTHANA S	ECE - B	/	/	/	/	/	/	/	/	/	/
32	731615106042	LOGAPRIYA M	ECE - B	/	/	/	/	/	/	P	P	/	/
33	731615106046	NAVEEN T S	ECE - B	P	a	/	/	/	/	/	/	a	/
34	731615106049	NIVETHA K	ECE - B	/	/	/	/	a	a	/	/	/	/
35	731615106050	NIVETHAN RAJ C	ECE - B	a	a	/	/	/	/	/	/	/	/
36	731615106053	PAVITHRA R	ECE - B	/	/	/	/	/	/	P	P	P	P
37	731615106054	PAVITHRA P	ECE - B	/	/	a	a	a	a	/	/	/	/

S. No	Reg No	Name	Branch	4.12.17		5.12.17		6.12.17		7.12.17		8.12.17	
				FN	AN	FN	AN	FN	AN	FN	AN	FN	AN
38	731615106057	PRAVEENKUMAR V	ECE - B	/	/	/	/	/	/	a	a	/	/
39	731615106059	PRIYADHARSHINI S	ECE - B	/	/	/	/	/	/	a	a	/	/
40	731615106061	PRIYANGA S	ECE - B	/	/	a	a	/	/	/	/	/	/
41	731615106063	RAMYA B	ECE - B	/	/	/	/	/	/	/	/	/	/
42	731615106064	RANJITHRAJA M	ECE - B	/	/	/	/	a	a	/	/	a	a
43	731615106065	SAKTHIVEL K	ECE - B	a	a	/	/	/	/	/	/	/	/
44	731615106066	SARANYA M	ECE - B	/	/	/	/	/	/	a	a	/	/
45	731615106067	SARASWATHI P	ECE - B	/	a	a	a	a	a	/	/	/	/
46	731615106068	SARAVANAKUMAR R	ECE - B	/	/	/	/	/	/	/	/	P	P
47	731615106069	SELVARAKESHKUMAR C	ECE - B	/	/	/	/	/	/	/	/	a	a
48	731615106070	SOWMIYA C	ECE - B	/	/	/	/	P	P	/	/	/	/
49	731615106071	SRIDHAR C	ECE - B	/	/	a	a	/	/	/	/	/	/
50	731615106072	SRIDHARAN S	ECE - B	/	/	/	/	/	/	/	/	/	/
51	731615106073	SUGANTHI S	ECE - B	/	/	/	/	a	a	/	/	/	/
52	731615106074	TAMILARASI J	ECE - B	a	a	/	/	/	/	/	/	/	/
53	731615106076	THARUNYA S	ECE - B	/	/	/	/	/	/	/	/	a	a
54	731615106077	UMA MAHESHWARI M	ECE - B	/	/	a	a	/	/	a	a	/	/
55	731615106078	VINAY V	ECE - B	/	/	/	/	/	/	/	/	/	/
56	731615106079	VINOTHINI G	ECE - B	/	/	/	/	a	P	/	/	/	/
57	731615106080	VINOTHKUMA M	ECE - B	/	/	/	/	/	/	/	/	a	a
58	731615106701	MAHESHWARI C	ECE - B	P	P	a	a	/	/	/	/	/	/
PRESENT				52	52	49	50	49	51	50	50	50	50
ABSENT				3	5	8	7	7	6	6	5	5	5
LEAVE				3	1	1	1	2	1	2	0	3	3
NOT INTEREST				0		0							

PRINCIPAL,  
K. S. R. INSTITUTE FOR  
ENGINEERING AND TECHNOLOGY,  
K. S. R. KALMI NAGAR,  
TIRUCHENGODE - 637 215,  
NAMAKKAL Dt, TAMIL NADU.

## Training and Placement Cell - EEE

## E Box Internal C &amp; Data Structure Training Attendance

BATCH : 2015 - 2019

Academic Year: 2017 - 2018

S. No	Reg No	Name	Branch	4.12.17		5.12.17		6.12.17		7.12.17		8.12.17	
				FN	AN	FN	AN	FN	AN	FN	AN	FN	AN
1	731615105046	LOHESH J	EEE B	/	/	/	/	/	/	P	P	/	/
2	731615105049	MAHAESWARI A	EEE B	/	/	/	/	/	/	/	/	/	/
3	731615105053	MOHAMMEDRIYAS A	EEE B	/	/	/	/	/	/	/	/	/	/
4	731615105055	MONISHA V	EEE B	a	/	/	/	/	/	/	/	/	/
5	731615105057	MURUGANANTH M	EEE B	/	/	a	a	/	/	P	P	/	/
6	731615105058	NAVEEN M T	EEE B	/	/	/	/	/	/	/	/	/	/
7	731615105059	NAVEEN KUMAR S	EEE B	/	P	/	/	/	/	/	/	/	/
8	731615105060	PAVITHRA M	EEE B	/	/	/	/	P	P	/	/	/	/
9	731615105062	POOJA R	EEE B	/	/	/	/	/	/	/	/	/	/
10	731615105065	PRIYADHARSHINI S	EEE B	/	/	/	/	/	/	/	/	a	a
11	731615105066	RAJASEKAR P V	EEE B	/	/	P	P	/	/	/	/	/	/
12	731615105067	RAMESH S R	EEE B	/	/	/	/	/	/	/	/	/	/
13	731615105071	SATHISH KUMAR M	EEE B	P	P	/	/	/	/	/	/	/	/
14	731615105072	SEKAR S	EEE B	/	/	/	/	/	/	a	a	/	/
15	731615105073	SOUNDHARYA S	EEE B	/	/	P	P	/	/	/	/	/	/
16	731615105075	SRINITHI G	EEE B	/	/	/	/	/	/	/	/	/	/
17	731615105076	SRINIVASAN R	EEE B	/	/	/	/	P	P	/	/	/	/
18	731615105077	STEPHEN IMMANUVEL	EEE B	/	/	/	/	/	/	/	/	/	/
19	731615105079	SWATHI R	EEE B	/	/	/	/	/	/	/	/	/	/
20	731615105085	VISHNU R	EEE B	/	/	/	/	/	/	/	/	/	/
21	731615105086	YOGAPRIYA S	EEE B	a	a	/	/	/	/	/	/	/	/
22	731615105087	YOGESHWARAN S	EEE B	/	/	/	/	/	/	/	/	/	/
23	731615105002	ARUNKUMAR C	EEE A	/	/	P	P	/	/	/	/	/	/
24	731615105005	CHIDAMBARAM V	EEE A	/	/	/	/	/	/	/	/	/	/
25	731615105007	DHIVAGAR N	EEE A	/	/	/	/	/	/	/	/	/	/
26	731615105008	DHIVAGAR S	EEE A	/	/	P	P	/	/	/	/	/	/
27	731615105011	ELANCHEZHIAN P	EEE A	/	/	/	/	/	/	/	/	/	/
28	731615105012	GAYATHRI K	EEE A	/	/	/	/	/	/	/	/	/	/
29	731615105021	GOWSALYA A	EEE A	/	/	P	P	/	/	/	/	/	/
30	731615105024	GOWTHAM V	EEE A	/	/	/	/	/	/	/	/	/	/
31	731615105026	HARIHARAN G	EEE A	a	/	/	/	/	/	/	/	/	/
32	731615105029	HARINI S	EEE A	/	/	/	/	/	/	/	/	/	/
33	731615105030	JANANI R	EEE A	/	/	a	a	/	/	/	/	/	/
34	731615105033	JEEVAPRAKASH V	EEE A	/	/	/	/	/	/	/	/	/	/
35	731615105034	KALAICHELVI V	EEE A	/	/	P	P	/	/	/	/	/	/
36	731615105035	KANNAN S	EEE A	/	/	/	/	/	/	/	/	/	/
37	731615105039	KEERTHIKA C	EEE A	/	/	P	P	/	/	/	/	/	/
38	731615105041	KODEESWARI M	EEE A	/	/	P	P	/	/	/	/	/	/
39	731615105042	KOKILAVANI M	EEE A	/	/	/	/	/	/	/	/	/	/
40	731615105044	KRISHNAMOORTHIS	EEE A	/	/	/	/	/	/	/	/	/	/
PRESENT				38	37	30	30	38	38	37	37	31	31
ABSENT				1	1	2	2	0	0	1	1	1	1
LEAVE				1	2	8	8	2	2	2	2	0	0

BATCH : 2015 - 2019

Academic Year: 2017 - 2018

S. No	Reg No	Name	Branch	4.12.17		5.12.17		6.12.17		7.12.17		8.12.17	
				FN	AN	FN	AN	FN	AN	FN	AN	FN	AN
1	731615114001	ADHISHANKARAN D	MECH - A	/	/	/	/	/	/	/	/	P	P
2	731615114009	ARAVINTHAN P V	MECH - A	/	/	/	/	P	P	/	/	/	/
3	731615114025	CELLAKAMALALAKSHMI D	MECH - A	/	/	/	/	/	/	/	/	P	P
4	731615114038	DINESHKUMAR T	MECH - A	P	P	/	/	/	/	/	/	/	/
5	731615114057	JAGADEESHBABU K	MECH - A	/	/	/	/	/	/	/	/	P	P
6	731615114098	NISHANTHI B	MECH - A	/	/	/	/	/	/	/	/	/	/
7	731615114066	KAVIPRIYAN S	MECH - B	/	/	/	/	/	/	/	/	/	/
8	731615114067	KESAVARAJ M	MECH - B	a	a	/	/	/	/	/	/	/	/
9	731615114077	MANIKANDAN P	MECH - B	/	/	/	/	/	/	/	/	P	P
10	731615114080	MANOJKUMAR P R	MECH - B	/	/	/	/	/	/	/	/	/	/
11	731615114083	MOHAN KUMAR R	MECH - B	/	/	/	/	/	/	/	/	/	/
12	731615114120	SANTHOSH K	MECH - C	/	/	P	P	/	/	/	/	/	/
13	731615114121	SANTHOSHKUMAR S	MECH - C	/	/	/	/	/	/	/	/	/	/
14	731615114123	SANTHOSH KUMAR R	MECH - C	/	/	/	/	/	/	/	/	/	/
15	731615114146	SURYA S C	MECH - C	/	/	/	/	/	/	/	/	/	/
16	731615114158	VIGNESH M	MECH - C	/	/	/	/	/	/	/	/	/	/
17	731615114162	VIJAY P	MECH - C	/	/	/	/	/	/	/	/	/	/
18	731615114313	NAVEEN A	MECH - C	/	/	/	/	/	/	/	/	/	/
19	731615114316	PRAVINTH .K	MECH - C	/	/	/	/	/	/	/	/	/	/
20	731615114318	RANJITHKUMAR .M	MECH - C	/	/	/	/	/	/	/	/	P	P
PRESENT				18	18	19	19	19	19	20	20	17	15
ABSENT				1	1	0	0	0	0	0	0	0	0
LEAVE				1	1	1	1	1	1	0	0	3	5
NOT INTEREST				-	-	-	-	-	-	-	-	-	-

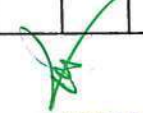
  
 PRINCIPAL,  
 K. S. R. INSTITUTE FOR  
 ENGINEERING AND TECHNOLOGY,  
 K. S. R. KALVI NAGAR,  
 TIRUCHENGODE - 637 215,  
 NAMANKAL DI, TAMIL NADU.



Name of the Student: C. Koorthika

Branch: EEE

Year / Sem: II / VI

1. Name of the Training: Data structure

2. Name of the Trainer: Sharmila

3. Students rating of Trainers :

S. No.	Date	Subject	Rating (✓)			
			Excellent	Very good	Good	Average
1	6/12/17	Data structure		✓		

4. Two positive points about the programme: 1) Easy understanding.  
2) know new programming.

5. Suggestions for improvement:

Nil.

C. Koorthika  
Signature

Date: 6/12/17



Name of the Student: C. Yogapriya

Branch: EEE

Year / Sem: II / VI

4. Name of the Training: Data structure

5. Name of the Trainer: sharmila

6. Students rating of Trainers :

S. No.	Date	Subject	Rating (✓)			
			Excellent	Very good	Good	Average
1	6/12/17	Data structure			✓	

4. Two positive points about the programme:  
✓ Understanding of each concepts good  
✓ clearing doubts was good

5. Suggestions for improvement:

✓ Fast going to complete the subject

Date:

PRINCIPAL,  
K. S. R. INSTITUTE FOR  
ENGINEERING AND TECHNOLOGY,  
K. S. R. K. NAGAR,  
TIRUCHENGODE - 637 215,  
NAMAKAL DI, TAMIL NADU.  
S. J. J.  
Signature



Name of the Student: STEPHENIMMANUEL J

Branch: EEE

Year / Sem: III - / VI

1.Name of the Training : DATA STRUCTURE

2.Name of the Trainer : M.DURGA

3.Students rating of Trainers :

S. No.	Date	Subject	Rating (√)			
			Excellent	Very good	Good	Average
1	6.12.17	DATA STRUCTURE				✓

4. Two positive points about the programme:

Good at explanation

5. Suggestions for improvement:

Start with basic of Data structure

Date: 6-12-17

S.S. Srinivasan  
Signature



Name of the Student: Anunkumar . c

Branch: EEE

Year / Sem: III / VI

4.Name of the Training : Data Structure

5.Name of the Trainer : M. Durga Devi

6.Students rating of Trainers : 90/100

S. No.	Date	Subject	Rating (√)			
			Excellent	Very good	Good	Average
1	6/12/17	Data Structure		✓		

4. Two positive points about the programme:

\* Basics explanation is good.

\* Need to improve more time to explain

5. Suggestions for improvement:

\* Time allocation is less.

\* The skillrack compiler contains very tough problem.

Date:

Anunkumar  
Signature  
PRINCIPAL,  
K. S. R. INSTITUTE FOR  
ENGINEERING AND TECHNOLOGY,  
K. S. R. KALVI NAGAR,  
TIRUCHENGODE - 637 215,  
NAMAKKAL DISTRICT, TAMIL NADU.





Name of the Student: P. Manikandan

Branch: Mechanical

Year / Sem: 3<sup>rd</sup> / VI

1. Name of the Training: Data Structure

2. Name of the Trainer:

3. Students rating of Trainers:

S. No.	Date	Subject	Rating (√)			
			Excellent	Very good	Good	Average
1	8/12/17	Data structure			✓	

4. Two positive points about the programme:

To know about types in data structure

5. Suggestions for improvement:

class going only theory part.  
Date: only gaining theory knowledge

[Signature]  
Signature



Name of the Student: M. Jaganaraj

Branch: MECH

Year / Sem: 3<sup>rd</sup> / VI

4. Name of the Training: Data structure

5. Name of the Trainer: M. Lawanya

6. Students rating of Trainers:

S. No.	Date	Subject	Rating (√)			
			Excellent	Very good	Good	Average
1	8/12/17	Data structure				✓

4. Two positive points about the programme:

To know the new topic in data structure

5. Suggestions for improvement:

Clear Explanation is required.

Date: 8/12/17

PRINCIPAL,  
K. S. R. INSTITUTE FOR  
ENGINEERING AND TECHNOLOGY,  
K. S. R. INSTITUTE FOR,  
TIRUCHENGODE - 637 215,  
NAMAKKAL DISTRICT, TAMIL NADU.  
[Signature]  
Signature

**K S R INSTITUTE FOR ENGINEERING AND TECHNOLOGY  
TIRUCHENGODE - 637 215**

**TRAINING PROGRAMME FEEDBACK FORM**



Name of the Student: DHIVAGAR

Branch: EEF

Year / Sem: III / VI

1. Name of the Training : Data Structure

2. Name of the Trainer :

3. Students rating of Trainers : 8/10

S. No.	Date	Subject	Rating (√)			
			Excellent	Very good	Good	Average
1	8/12/17				✓	

4. Two positive points about the programme:

*Learning with lot of examples  
Applications with C programming was easy to learn*

5. Suggestions for improvement:

*Teaching with more slides is important*

Date: 8/12/17

Signature *S. J. Logan*

**K S R INSTITUTE FOR ENGINEERING AND TECHNOLOGY  
TIRUCHENGODE - 637 215**

**TRAINING PROGRAMME FEEDBACK FORM**



Name of the Student: chidambaram .v

Branch: EEF

Year / Sem: III / V

4. Name of the Training : Data Structure

5. Name of the Trainer :

6. Students rating of Trainers :

S. No.	Date	Subject	Rating (√)			
			Excellent	Very good	Good	Average
1	8/12/17				✓	

4. Two positive points about the programme:

*Programme planning was good.*

5. Suggestions for improvement:

*nil*

Date: 8/12/17

**PRINCIPAL,**  
**K. S. R. INSTITUTE FOR**  
**ENGINEERING AND TECHNOLOGY,**  
**K. S. R. KALM NAGAR,**  
**TIRUCHENGODE - 637 215,**  
**NAMAKKAL DN, TAMIL NADU.**

*V. Chidambaram*

Signature

BATCH: 2015 - 2019

ACADEMIC YEAR: 2017 - 2018 [ Even]

DATE: 04.12.2017

## Fore Noon session

S.NO	BRANCH	STRENGTH	No of Placement Registered Students	PRESENT	ABSENT	LEAVE
1	CSE	47	30	18	5	7
2	ECE - A	39	30	29	0	1
3	ECE - B	42	28	23	3	2
4	EEE - A	45	18	18	0	0
5	EEE - B	45	22	20	1	1
6	IT	39	25	17	3	5
7	MECH - A	61	6	5	0	1
8	MECH - B	59	5	5	0	0
9	MECH - C	60	9	8	1	0
<b>Total</b>		<b>437</b>	<b>173</b>	<b>143</b>	<b>13</b>	<b>17</b>

## After Noon Session

S.NO	BRANCH	STRENGTH	No of Placement Registered Students	PRESENT	ABSENT	PERMISSION
1	CSE	47	30	18	5	7
2	ECE - A	39	30	30	0	0
3	ECE - B	42	28	21	5	2
4	EEE - A	45	18	18	0	0
5	EEE - B	45	22	19	1	2
6	IT	39	25	17	3	5
7	MECH - A	61	6	5	0	1
8	MECH - B	59	5	5	0	0
9	MECH - C	60	9	8	1	0
<b>Total</b>		<b>437</b>	<b>173</b>	<b>141</b>	<b>15</b>	<b>17</b>

  
T & P OFFICER

  
T & P COORDINATOR

  
PRINCIPAL

PRINCIPAL,  
K. S. R. INSTITUTE FOR  
ENGINEERING AND TECHNOLOGY,  
K. S. R. KALYAN NAGAR,  
TIRUCHENGODE - 637 215,  
NAMAKKAL DISTRICT, TAMIL NADU.

BATCH: 2015 - 2019

ACADEMIC YEAR: 2017 - 2018 [ Even]

DATE: 05.12.2017

## Fore Noon session

S.NO	BRANCH	STRENGTH	No of Placement Registered Students	PRESENT	ABSENT	LEAVE
1	CSE	47	30	19	8	3
2	ECE - A	39	30	28	2	0
3	ECE - B	42	28	21	6	1
4	EEE - A	45	18	11	1	6
5	EEE - B	45	22	19	1	2
6	IT	39	25	22	2	1
7	MECH - A	61	6	5	0	1
8	MECH - B	59	5	5	0	0
9	MECH - C	60	9	9	0	0
<b>Total</b>		<b>437</b>	<b>173</b>	<b>139</b>	<b>20</b>	<b>14</b>

## After Noon Session

S.NO	BRANCH	STRENGTH	No of Placement Registered Students	PRESENT	ABSENT	PERMISSION
1	CSE	47	30	19	8	3
2	ECE - A	39	30	29	1	0
3	ECE - B	42	28	21	6	1
4	EEE - A	45	18	11	1	6
5	EEE - B	45	22	19	1	2
6	IT	39	25	22	2	1
7	MECH - A	61	6	5	0	1
8	MECH - B	59	5	5	0	0
9	MECH - C	60	9	9	0	0
<b>Total</b>		<b>437</b>	<b>173</b>	<b>140</b>	<b>19</b>	<b>14</b>

*[Signature]*  
T & P OFFICER  
5/12/17

*[Signature]*  
T & P COORDINATOR

*[Signature]*  
PRINCIPAL

PRINCIPAL,  
K. S. R. INSTITUTE FOR  
ENGINEERING AND TECHNOLOGY,  
K. S. R. KALVI NAGAR,  
TIRUCHENGODE - 637 215,  
NAMAKKAL Dt, TAMIL NADU.

BATCH: 2015 - 2019

ACADEMIC YEAR: 2017 - 2018 [ Even]

DATE: 06.12.2017

## Fore Noon session

S.NO	BRANCH	STRENGTH	No of Placement Registered Students	PRESENT	ABSENT	LEAVE
1	CSE	47	30	20	10	0
2	ECE - A	39	30	28	1	1
3	ECE - B	42	28	21	6	1
4	EEE - A	45	11	11	0	0
5	EEE - B	45	20	18	0	2
6	IT	39	25	21	3	1
7	MECH - A	61	6	5	0	1
8	MECH - B	59	5	5	0	0
9	MECH - C	60	2	2	0	0
<b>Total</b>		<b>437</b>	<b>157</b>	<b>131</b>	<b>20</b>	<b>6</b>

## After Noon Session

S.NO	BRANCH	STRENGTH	No of Placement Registered Students	PRESENT	ABSENT	LEAVE
1	CSE	47	30	21	9	0
2	ECE - A	39	30	29	1	0
3	ECE - B	42	28	22	5	1
4	EEE - A	45	11	11	0	0
5	EEE - B	45	20	18	0	2
6	IT	39	25	21	3	1
7	MECH - A	61	6	5	0	1
8	MECH - B	59	5	5	0	0
9	MECH - C	60	2	2	0	0
<b>Total</b>		<b>437</b>	<b>157</b>	<b>134</b>	<b>18</b>	<b>5</b>

*[Signature]*  
T & P OFFICER

*[Signature]*  
T & P COORDINATOR

*[Signature]*  
PRINCIPAL

PRINCIPAL,  
K. S. R. INSTITUTE FOR  
ENGINEERING AND TECHNOLOGY,  
K. S. R. KALVI NAGAR,  
TIRUCHENGODE - 637 215,  
NAMASKAL IN, TAMIL NADU.

Fore Noon session

S.NO	BRANCH	STRENGTH	No of Placement Registered Students	PRESENT	ABSENT	LEAVE
1	CSE	47	30	20	9	1
2	ECE - A	39	30	28	1	1
3	ECE - B	42	28	22	5	1
4	EEE - A	45	11	11	0	0
5	EEE - B	45	20	17	1	2
6	IT	39	25	21	3	1
7	MECH - A	61	6	6	0	0
8	MECH - B	59	5	5	0	0
9	MECH - C	60	2	2	0	0
<b>Total</b>		<b>437</b>	<b>157</b>	<b>132</b>	<b>19</b>	<b>6</b>

After Noon Session

S.NO	BRANCH	STRENGTH	No of Placement Registered Students	PRESENT	ABSENT	LEAVE
1	CSE	47	30	22	6	2
2	ECE - A	39	30	29	1	0
3	ECE - B	42	28	23	4	1
4	EEE - A	45	11	11	0	0
5	EEE - B	45	20	17	1	2
6	IT	39	25	22	2	1
7	MECH - A	61	6	6	0	0
8	MECH - B	59	5	5	0	0
9	MECH - C	60	2	2	0	0
<b>Total</b>		<b>437</b>	<b>157</b>	<b>137</b>	<b>14</b>	<b>6</b>

*P. Lakshmi*  
T&P Officer

*[Signature]*  
- T & P Coordinator

*[Signature]*  
Principal

*[Signature]*  
Principal

PRINCIPAL,  
K. S. R. INSTITUTE FOR  
ENGINEERING AND TECHNOLOGY,  
K. S. R. KALVI NAGAR,  
TIRUCHENGODE - 637 215,  
NAMAKKAL DISTRICT, TAMIL NADU.

BATCH: 2015 - 2019

ACADEMIC YEAR: 2017 - 2018 [ Even]

DATE: 08.12.2017

## Fore Noon session

S.NO	BRANCH	STRENGTH	No of Placement Registered Students	PRESENT	ABSENT	LEAVE
1	CSE	47	29	23	6	0
2	ECE - A	39	30	28	1	1
3	ECE - B	42	28	22	4	2
4	EEE - A	45	11	11	0	0
5	EEE - B	45	20	19	1	0
6	IT	39	25	23	2	0
7	MECH - A	61	6	5	0	1
8	MECH - B	59	5	4	0	1
9	MECH - C	60	2	1	0	1
<b>Total</b>		<b>437</b>	<b>156</b>	<b>136</b>	<b>14</b>	<b>6</b>

## After Noon Session

S.NO	BRANCH	STRENGTH	No of Placement Registered Students	PRESENT	ABSENT	LEAVE
1	CSE	47	29	23	6	0
2	ECE - A	39	30	28	1	1
3	ECE - B	42	28	22	4	2
4	EEE - A	45	11	11	0	0
5	EEE - B	45	20	19	1	0
6	IT	39	25	23	2	0
7	MECH - A	61	6	3	0	3
8	MECH - B	59	5	4	0	1
9	MECH - C	60	2	1	0	1
<b>Total</b>		<b>437</b>	<b>156</b>	<b>134</b>	<b>14</b>	<b>8</b>

Y. Kaluth  
T & P Officer

T & P Coordinator

Principal



**K S R INSTITUTE FOR ENGINEERING AND TECHNOLOGY**  
**Tiruchengode, Namakkal – 637215**

**Department of Mechanical Engineering**

## **Value Added Course – Syllabus**

The course covers the topics you need to review for the **AutoCAD** including:

### **Module 1: INTRODUCTION TO AUTOCAD**

6

AutoCAD Screen Components- Drawing Area Command -Window Navigation bar Status bar  
AUTOCAD Introduction-Software Requirements- Files handling in CAD- Draw toolbar- Modify  
toolbar- Dimensioning toolbar- Opening an Existing Drawing- Quitting AutoCAD

### **Module 2: Introduction to OF Tool bars**

7

Functional keys and properties - Layers and leaders- Tool menu customization- Geometric  
constraints- Dimension constraints- Drawing Lines in AutoCAD- Invoking tools Using Dynamic  
INPUT/Command- Prompt Coordinate Systems

### **Module 3: Starting With Advanced Sketching**

8

Drawing Arcs- Drawing Rectangles -Drawing Ellipses- Drawing Regular Polygon- Drawing  
Polylines Placing Points -Drawing Infinite Lines Writing a Single Line Text- Working with Layers-  
Object Properties- Drafting Settings dialog box

### **Module 4: Editing Sketched Objects**

9

Editing Sketches- Moving the Sketched Objects -Copying the Sketched Objects- Creating Multiple  
Copies Creating a Single Copy Offsetting Sketched Objects- Rotating Sketched Objects Scaling the  
Sketched Objects -Filletting the Sketches- Chamfering the Sketches- Trimming the Sketched Objects  
Extending the Sketched Objects- Stretching the Sketched Objects -Lengthening the Sketched  
Objects -objects Text Mirroring

### **Module 5: Isometric Drawings**

8

Isometric drawings- Extrusion-View, visual styles and orbit- Solid (3D) modelling- Solid editing  
operations- Rendering and scenes

  
COORDINATOR

  
Dr. M. VENKATESAN, M.E., Ph.D. Total: 38 Hours  
PRINCIPAL,  
K S R INSTITUTE FOR  
ENGINEERING AND TECHNOLOGY,  
K.S.R. KALVI NAGAR,  
TIRUCHENGODE-637 215,  
NAMAKKAL Dt, TAMIL NADU.



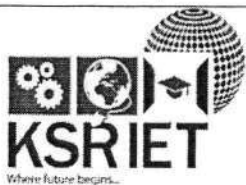

**K S R INSTITUTE FOR ENGINEERING AND TECHNOLOGY**  
**Tiruchengode, Namakkal – 637215**

**Department of Mechanical Engineering**

## Value Added Course - AutoCAD

### Schedule

**Date: 03/07/2017**

S.No.	Date	Topic	Name of the Faculty
1.	10/07/17	AutoCAD Screen Components- Drawing Area Command Window Navigation bar Status bar AUTOCAD Introduction	Mr.L.Selvakumar (United cad) Mr.M.kannan (United cad) Mr.S.Baskaran
2.	11/07/17	Software Requirements- Files handling in CAD- Draw toolbar	Mr.L.Selvakumar (United cad) Mr.M.kannan (United cad) Mr.D.Ramkumar
3.	12/07/17	Modify toolbar- Dimensioning toolbar	Mr.L.Selvakumar (United cad) Mr.M.kannan (United cad) Mr.S.Baskaran
4.	13/07/17	Opening an Existing Drawing- Quitting AutoCAD	Mr.L.Selvakumar (United cad) Mr.M.kannan (United cad) Mr.D.Ramkumar
5.	14/07/17	Functional keys and properties - Layers and leaders- Tool menu customization	Mr.L.Selvakumar (United cad) Mr.M.kannan (United cad) Mr.S.Baskaran
6.	17/07/17	Geometric constraints- Dimension constraints	Mr.L.Selvakumar (United cad) Mr.M.kannan (United cad) Mr.D.Ramkumar
7.	18/07/17	Drawing Lines in AutoCAD	Mr.L.Selvakumar (United cad) Mr.M.kannan (United cad) Mr.S.Baskaran

Dr. M. VENKATESAN, M.E., Ph.D.,  
 PRINCIPAL,  
 K S R INSTITUTE FOR  
 ENGINEERING AND TECHNOLOGY,  
 K.S.R. KALVI NAGAR,  
 TIRUCHENGODE-637 215,  
 NAMAKKAL DISTRICT, TAMIL NADU.

8.	19/07/17	Invoking tools Using Dynamic INPUT/Command-Prompt Coordinate Systems	Mr.L.Selvakumar (United cad) Mr.M.kannan (United cad) Mr.D.Ramkumar
9.	20/07/17	Drawing Arcs- Drawing Rectangles -Drawing Ellipses	Mr.L.Selvakumar (United cad) Mr.M.kannan (United cad) Mr.S.Baskaran
10.	21/07/17	Drawing Regular Polygon- Drawing Polylines Placing Points	Mr.L.Selvakumar (United cad) Mr.M.kannan (United cad) Mr.D:Ramkumar
11.	31/07/17	Drawing Infinite Lines Writing a Single Line Text	Mr.L.Selvakumar (United cad) Mr.M.kannan (United cad) Mr.S.Baskaran
12.	01/08/17	Working with Layers- Object Properties- Drafting Settings dialog box	Mr.L.Selvakumar (United cad) Mr.M.kannan (United cad) Mr.D.Ramkumar
13.	02/08/17	Editing Sketches- Moving the Sketched Objects - Copying the Sketched Objects	Mr.L.Selvakumar (United cad) Mr.M.kannan (United cad) Mr.S.Baskaran
14.	04/08/17	Creating Multiple Copies Creating a Single Copy Offsetting Sketched Objects- Rotating Sketched Objects Scaling the Sketched Objects	Mr.L.Selvakumar (United cad) Mr.M.kannan (United cad) Mr.D.Ramkumar
15.	05/08/17	Filleting the Sketches- Chamfering the Sketches- Trimming the Sketched Objects Extending the Sketched Objects	Mr.L.Selvakumar (United cad) Mr.M.kannan (United cad) Mr.S.Baskaran
16.	07/08/17	Stretching the Sketched Objects -Lengthening the Sketched Objects -objects Text Mirroring	Mr.L.Selvakumar (United cad) Mr.M.kannan (United cad) Mr.D.Ramkumar
17.	08/08/17	Isometric drawings- Extrusion	Mr.L.Selvakumar (United cad) Mr.M.kannan (United cad) Mr.S.Baskaran
18.	09/08/17	View, visual styles and orbit	Mr.L.Selvakumar (United cad)

Dr. M. VENKATESAN, M.E., Ph.D.,  
PRINCIPAL,

K S R INSTITUTE FOR  
ENGINEERING AND TECHNOLOGY,  
K.S.R. KALVI NAGAR.

			Mr.M.kannan (United cad) Mr.D.Ramkumar
19.	10/08/17	Solid (3D) modelling	Mr.L.Selvakumar (United cad) Mr.M.kannan (United cad) Mr.G.Gowrisankar
20.	11/08/17	Solid editing operations- Rendering and scenes	Mr.L.Selvakumar (United cad) Mr.M.kannan (United cad) Mr.D.Ramkumar

  
COORDINATOR

  
HOD

  
Dr.,M. VENKATESAN, M.E., Ph.D.,  
PRINCIPAL,  
K S R INSTITUTE FOR  
ENGINEERING AND TECHNOLOGY,  
K.S.R. KALVI NAGAR,  
TIRUCHENGODE-637 215,  
NAMAKKAL Dt, TAMIL NADU.

**K S R Institute for Engineering and Technology**  
**Department of Mechanical Engineering**  
**Value Added Course on AUTO CAD**

Year:II

Attendance

Academic Year:2017-18

S.NO	REG.NO	NAME OF THE STUDENT	10.07.	11.07.	12.07.	13.07.	14.07.	17.07.	18.07.	19.07.	20.07.	21.07.	31.07.	01.08.	02.08.	03.08.	04.08.	05.08.	07.08.	08.08.	09.08.	10.08.	11.08.
			17	17	17	17	17	17	17	17	17	17	17	17	17	17	17	17	17	17	17	17	17
1	731616114001	Aakash S	/	/	/	/	/	/	/	/	/	/	/	/	/	/	/	/	/	/	/	/	/
2	731616114002	Ajith M	/	/	/	/	/	/	/	/	/	/	/	/	/	/	/	/	/	/	/	/	/
3	731616114003	Annamalai K	/	/	A	/	/	/	/	/	/	/	/	/	/	/	/	/	/	A	/	/	/
4	731616114004	Arshath S	/	/	/	/	/	/	/	/	/	/	/	/	/	/	/	/	/	/	/	/	/
5	731616114005	Aswinkumar S	/	/	/	/	/	/	/	/	/	/	/	/	/	/	/	/	/	/	/	/	/
6	731616114006	Bharath V	/	/	/	/	/	/	/	/	/	/	/	/	/	/	/	/	/	/	/	/	/
7	731616114007	Boopathi Raja E	/	/	/	/	/	/	/	/	/	/	/	/	/	/	/	A	/	/	/	/	/
8	731616114008	Boopathy K M	/	/	/	/	/	/	/	/	/	/	/	/	/	/	/	/	/	/	/	/	/
9	731616114009	Chandrasekar K	/	/	/	/	A	/	/	/	/	/	/	/	/	/	/	/	/	/	/	/	/
10	731616114010	Chellathurai T	/	/	/	/	/	/	/	/	/	/	/	/	/	/	/	/	/	/	/	/	/
11	731616114011	Deepak R	/	/	/	/	/	/	/	/	/	/	A	/	/	A	/	/	/	/	/	/	/
12	731616114012	Dhayaniidhi M	/	/	/	/	/	/	/	/	/	/	/	/	/	/	/	/	/	/	/	/	/
13	731616114015	Dinesh Kumar C	/	/	/	/	/	/	/	/	/	/	/	/	/	/	/	/	/	/	/	/	/
14	731616114016	Gokul R	/	/	/	/	/	/	/	/	/	/	/	/	/	/	/	/	/	/	/	/	/
15	731616114017	Gokulraj P	/	/	/	/	/	/	/	/	A	/	/	/	/	/	A	/	/	/	/	/	/
16	731616114018	Gopinath G	/	/	/	/	/	/	/	/	/	/	/	/	/	/	/	/	/	/	/	/	/
17	731616114019	Govindasamy A	/	/	/	/	/	/	/	/	/	/	/	/	/	/	/	/	/	/	/	/	/
18	731616114020	Gowtham P	/	/	/	/	/	/	/	/	/	/	/	/	/	/	/	/	/	/	/	/	/
19	731616114021	Gunasekaran R	/	/	/	/	/	/	/	/	/	/	/	/	/	/	/	/	/	/	/	/	/
20	731616114022	Hariharan M	/	/	/	/	/	/	/	/	/	/	/	A	/	/	/	/	/	/	/	/	/
21	731616114023	Hariharan S	/	/	/	/	/	/	/	/	/	/	/	/	/	/	/	/	/	/	/	/	/
22	731616114024	Hari Shankar P	/	/	/	/	/	/	/	/	/	/	A	/	/	/	/	/	/	/	/	/	/
23	731616114025	Inbarasan C	/	/	/	/	/	/	/	/	/	/	/	/	/	/	/	/	/	/	/	/	/
24	731616114027	Jayamurugan K S	/	/	A	/	/	/	/	/	/	/	/	/	/	/	/	/	/	/	/	/	/
25	731616114028	Jeeva K	/	/	/	/	/	A	/	/	/	/	/	/	/	/	/	/	/	/	/	/	/
26	731616114029	Jeeva M	/	/	/	/	/	/	/	/	/	/	/	/	/	/	/	/	/	/	/	/	/
27	731616114030	Jestinraj K	/	/	/	/	/	/	/	/	/	/	/	/	/	/	/	/	/	/	/	/	/
28	731616114031	Joshua Y	/	/	/	/	/	/	/	/	/	/	/	/	/	/	/	/	/	/	/	/	/
29	731616114032	Kaleeswaran D	/	/	/	/	/	/	/	/	/	/	/	/	/	/	/	/	/	/	/	/	/
30	731616114033	Karole Infanto D	/	/	/	/	/	/	/	/	/	/	/	/	/	/	/	/	/	/	/	/	/
31	731616114034	Karthikeyan P	/	/	/	/	/	/	/	/	/	/	/	/	/	/	/	/	/	/	/	/	/
32	731616114035	Kavin P	/	/	/	/	/	/	/	/	/	/	/	/	/	/	/	/	/	/	/	/	/

Dr. M. VENKATESAN, M.E., Ph.D.,  
 PRINCIPAL,  
 K S R INSTITUTE FOR  
 ENGINEERING AND TECHNOLOGY,  
 K.S.R. KALVI NAGAR,  
 TIRUCHENGODE-637 215,  
 NAMAKKAL Dt, TAMIL NADU.

S.NO	REG.NO	NAME OF THE STUDENT	10.07.17	11.07.17	12.07.17	13.07.17	14.07.17	17.07.17	18.07.17	19.07.17	20.07.17	21.07.17	31.07.17	01.08.17	02.08.17	03.08.17	04.08.17	05.08.17	07.08.17	08.08.17	09.08.17	10.08.17	11.08.17	
33	731616114036	Kavinkumar R	/	/	/	/	/	/	/	/	/	/	/	/	/	/	/	/	/	/	/	/	/	/
34	731616114037	Keerthivasan S	(	)	/	/	/	/	/	/	/	/	/	/	/	/	/	/	/	/	/	/	/	/
35	731616114038	Kesav Goutham N B	/	/	/	/	/	/	/	/	/	/	/	/	/	/	/	/	/	/	/	/	/	/
36	731616114040	Kirubakaran M	/	/	/	/	/	/	/	/	/	/	/	/	/	/	/	/	/	/	/	/	/	/
37	731616114041	Lakshmi Narayanan R	/	/	/	/	/	/	/	/	/	/	/	/	/	/	/	A	/	/	/	/	/	/
38	731616114042	Logesh N	/	/	/	/	/	/	/	/	/	/	/	/	/	/	/	/	/	/	/	/	/	/
39	731616114043	Logesh S	(	)	/	/	/	/	/	/	/	/	/	/	/	/	/	/	/	/	/	/	/	/
40	731616114044	Madhankumar L	/	/	/	/	/	A	/	/	/	/	/	/	/	/	/	/	/	/	/	/	/	/
41	731616114045	Mageswaran A	/	/	/	/	/	/	/	/	/	/	/	/	/	/	/	/	/	/	/	/	/	/
42	731616114046	Manikandan V	/	/	/	/	/	/	/	/	/	/	/	/	/	/	/	/	/	/	/	/	/	/
43	731616114047	Manojkumar K	/	/	/	/	/	/	/	/	/	/	/	/	A	A	/	/	/	/	/	/	/	/
44	731616114048	Mohammed Nihal R	/	/	/	/	/	/	/	/	/	/	/	/	/	/	/	/	/	/	/	/	/	/
45	731616114049	Mohanakrishnan D	(	A	/	/	/	/	/	/	/	A	/	/	/	/	/	/	/	/	/	/	/	/
46	731616114050	Mohan Arjun Kumaravel	/	/	/	/	/	/	/	/	/	/	/	/	/	/	/	/	/	/	/	/	/	/
47	731616114051	Mohanraj B	/	/	/	/	/	/	/	/	/	/	/	/	/	/	/	/	/	/	/	/	/	/
48	731616114052	Nambiraj J	/	/	/	/	/	/	/	/	/	/	/	/	/	/	/	/	/	/	/	/	/	/
49	731616114053	Nandhagobal S	/	/	/	/	/	A	A	/	/	/	/	A	/	/	/	/	/	/	/	/	/	/
50	731616114057	Prabhakaran M	/	/	/	/	/	/	/	/	/	/	/	/	/	/	/	/	/	/	/	/	/	/
51	731616114058	Prasanth R	/	/	/	/	/	/	/	/	/	/	/	/	/	/	/	/	/	/	/	/	/	/
52	731616114059	Praveen R (07-01-1999)	/	/	/	/	A	/	/	/	/	/	/	/	/	/	/	/	/	/	/	/	/	/
53	731616114060	Praveen R (31-03-1999)	/	/	/	/	/	/	/	/	/	/	/	/	/	/	/	/	/	/	/	/	/	/
54	731616114061	Praveenkumar S	/	/	/	/	/	/	/	/	/	/	/	/	/	/	/	/	/	/	/	/	/	/
55	731616114062	Prem Kumar K R	/	/	/	/	/	/	/	/	/	/	/	/	/	/	/	/	/	/	/	/	/	/
56	731616114063	Ragavendhar S	(	/	A	/	/	/	A	/	/	/	/	/	/	/	/	/	/	/	/	/	/	/
57	731616114064	Rahul C	/	/	/	/	/	/	/	/	/	/	/	/	/	/	/	/	/	/	/	/	/	/
58	731616114065	Rajkumar S	/	/	/	/	/	/	/	/	/	/	/	/	/	/	/	/	/	/	/	/	/	/
59	731616114066	Ranjith R	(	/	A	/	/	/	/	/	/	/	A	/	/	/	/	/	/	A	/	/	/	/
60	731616114067	Ranjithkumar R	/	/	/	/	/	/	/	/	/	/	/	/	/	/	/	/	/	/	/	/	/	/
61	731616114068	Ranjith Kumar V	/	A	/	/	/	/	/	/	/	/	/	A	/	/	/	/	/	A	/	/	/	/
62	731616114069	Ravichandran S	/	/	/	/	/	/	/	/	/	/	/	/	/	/	/	/	/	/	/	/	/	/
63	731616114070	Riyaz Ahamed S	(	/	/	/	/	/	/	/	/	/	/	/	/	/	/	/	/	/	/	/	/	/
64	731616114071	Ruthrannan B	/	/	/	/	/	/	/	/	/	/	/	/	/	/	/	/	/	/	/	/	/	/
65	731616114072	Sabarish R	(	/	/	/	/	/	/	/	/	/	/	/	/	/	/	/	/	/	/	/	/	/
66	731616114073	Sakthi Gnanasundaram R	/	/	/	/	/	/	/	/	/	/	/	/	/	/	/	/	/	/	/	/	/	/
67	731616114074	Sakthivel R	/	/	/	/	/	/	/	/	/	/	/	/	/	/	/	/	/	/	/	/	/	/

  
 Dr. M. VENKATESAN, M.E., Ph.D.,  
 PRINCIPAL,  
 K S R INSTITUTE FOR  
 ENGINEERING AND TECHNOLOGY,  
 K.S.R. KALVI NAGAR,  
 TIRUCHENGODE-637 215,  
 NAMAKKAL DI, TAMIL NADU.

S.NO	REG.NO	NAME OF THE STUDENT	10.07.17	11.07.17	12.07.17	13.07.17	14.07.17	17.07.17	18.07.17	19.07.17	20.07.17	21.07.17	31.07.17	01.08.17	02.08.17	03.08.17	04.08.17	05.08.17	07.08.17	08.08.17	09.08.17	10.08.17	11.08.17
68	731616114075	Sanjay Kumar S	/	/	/	/	/	/	A	/	/	/	/	/	/	/	/	/	/	/	/	/	/
69	731616114076	Sanjay Kumar S K	/	/	/	/	/	/	/	/	/	/	/	/	/	/	/	/	/	/	/	/	/
70	731616114077	Santhoshkumar B	/	/	/	/	/	/	/	/	/	/	A	/	/	/	/	/	/	A	/	/	/
71	731616114078	Santhoshkumar V	/	/	/	/	/	/	/	/	/	/	/	/	/	/	/	/	/	/	/	/	/
72	731616114079	Saran K	/	/	/	/	/	/	/	/	/	/	/	/	/	/	/	/	/	/	/	/	/
73	731616114080	Saranraj S	/	/	/	/	/	/	/	/	/	/	/	/	A	A	/	/	/	/	/	/	/
74	731616114081	Sathish G	/	/	/	/	/	/	/	A	/	/	/	/	/	/	/	/	/	/	/	/	/
75	731616114082	Shakthi R M	/	/	/	/	/	/	/	/	/	/	/	/	/	/	/	/	/	/	/	/	/
76	731616114083	Sowndhar A	/	/	/	/	/	/	/	/	/	/	/	/	/	/	/	/	/	/	/	/	/
77	731616114086	Thamotharan J	/	A	A	/	/	/	/	/	/	/	/	/	/	/	/	/	/	/	/	/	/
78	731616114087	Thirumurugan V	/	/	/	/	/	/	/	/	/	/	/	/	/	/	/	/	/	/	/	/	/
79	731616114088	Uthaya Kumar M	/	/	/	/	/	/	/	/	/	/	/	/	/	/	/	/	/	/	/	/	/
80	731616114089	Vasanth S	/	/	/	/	/	/	/	/	/	/	/	/	/	/	/	/	/	/	/	/	/
81	731616114090	Vasantha Kumar P	/	/	/	/	A	/	A	/	/	/	/	/	/	/	/	/	/	/	/	/	/
82	731616114091	Velmurugan T	/	/	/	/	/	/	/	/	/	/	/	/	/	/	/	/	/	/	/	/	/
83	731616114092	Vignesh B	/	/	/	/	/	/	/	/	/	/	/	/	/	/	/	/	/	/	/	/	/
84	731616114093	Vignesh V	/	/	/	/	/	/	/	/	/	/	/	A	/	/	/	/	A	/	/	/	/
85	731616114094	Vijay Anand G	/	/	/	/	/	/	/	/	/	/	/	/	/	/	/	/	/	/	/	/	/
86	731616114095	Vijayaragavan P	/	/	/	/	/	/	/	/	/	/	/	/	/	/	/	/	/	/	/	/	/
87	731616114096	Vinothmani M	/	/	/	/	/	A	/	/	/	/	/	/	/	/	/	/	/	/	/	/	/
88	731616114097	Vishnu A	/	/	/	/	/	/	/	/	/	/	/	/	/	/	/	/	/	/	/	/	/
89	731616114098	Vivek P	/	/	/	/	/	/	/	/	/	/	/	/	/	/	/	/	/	/	/	/	/
90	731616114099	Yogaraj G	/	/	/	/	/	/	/	/	/	/	/	/	/	/	/	/	A	A	/	/	/
91	731616114100	Yogesh T	/	/	/	/	/	/	/	/	/	/	/	/	/	/	/	/	/	/	/	/	/
92	731616114302	balaji M	/	/	/	/	/	/	/	/	/	/	A	/	/	/	/	/	/	/	/	/	/
93	731616114303	Barath V	/	/	/	/	/	/	/	/	/	/	/	/	/	/	/	/	/	/	/	/	/
94	731616114304	Ethayakumar G	/	/	/	/	/	A	/	/	A	/	/	/	/	/	/	/	/	/	/	/	/
95	731616114305	Jeevanandham N	/	/	/	/	/	/	/	/	/	/	/	/	/	/	/	/	/	/	/	/	/
96	731616114306	Karathi S	/	/	/	/	/	/	/	/	/	/	/	/	/	/	/	/	/	/	/	/	/
97	731616114307	PRAKSAH.S	/	/	/	/	/	/	/	/	/	/	/	/	/	/	/	/	/	A	/	/	/
98	731616114310	SHANMUGA MANIVEL	/	/	/	/	/	/	/	/	/	/	/	/	/	/	/	/	/	/	/	/	/
99	731616114311	SURENTHARAN.J	/	/	/	/	/	/	/	/	/	/	/	/	/	/	/	A	/	/	/	/	/
Course Coordinator			<i>[Handwritten Signature]</i>																				
HoD			<i>[Handwritten Signature]</i>																				

Dr. M. VENKATESAN, M.E., Ph.D.,  
 PRINCIPAL,  
 K S R INSTITUTE FOR  
 ENGINEERING AND TECHNOLOGY,  
 K.S.R. KALMI NAGAR,  
 TIRUCHENGODE-637 215,  
 NAMAKKAL DI, TAMIL NADU.

**KSR INSTITUTE FOR ENGINEERING AND TECHNOLOGY  
DEPARTMENT OF MECHANICAL ENGINEERING**

Centre for Value Added Education (CENVAE)

Assessment Test for AUTOCAD course

Attend any one question

Date:  
MARK (50)

1. Draw the following 2D diagram in AUTOCAD software

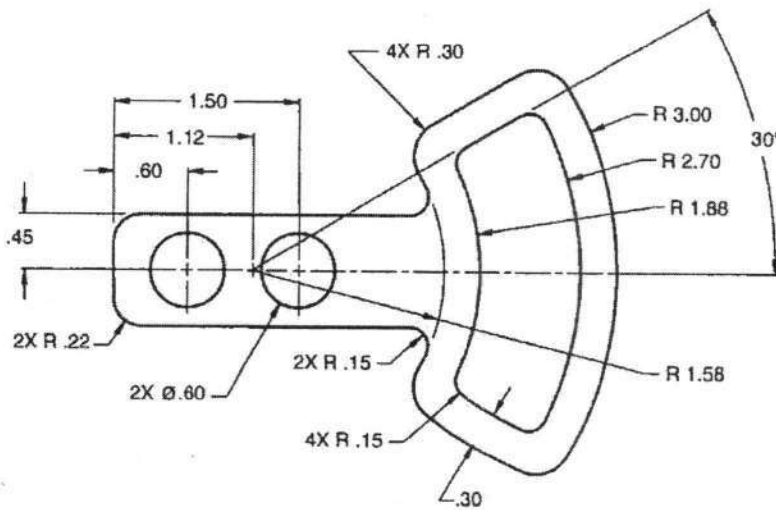

2. Draw the following 2D diagram in AUTOCAD software

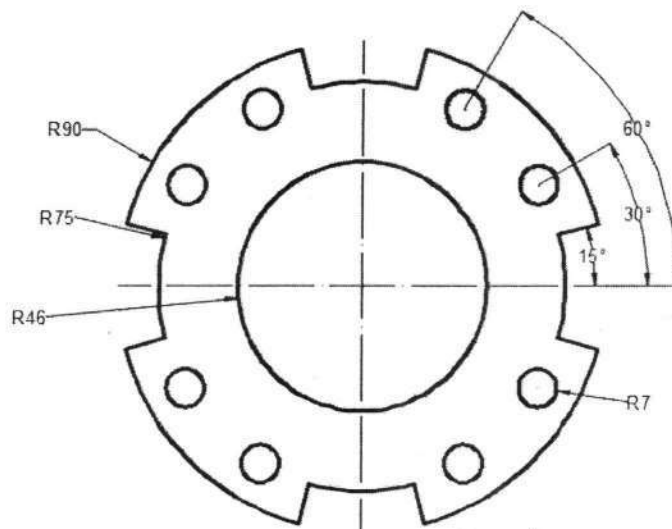

COORDINATOR

Dr. M. VENKATESAN, M.E., Ph.D.,  
PRINCIPAL,  
K S R INSTITUTE FOR  
ENGINEERING AND TECHNOLOGY,  
K.S.R. KALVI NAGAR,  
TIRUCHENGODE-637 215,  
NAMAKKAL DL, TAMIL NADU.

HOD

**K S R Institute for Engineering and Technology****Department of Mechanical Engineering****Value Added Course on AUTO CAD****Year : II****Assesment Marks****Academic year: 2017-18**

S.NO	REG.NO	NAME OF THE STUDENT	Marks(50)
1	731616114001	Aakash S	45
2	731616114002	Ajith M	45
3	731616114003	Annamalai K	39
4	731616114004	Arshath S	40
5	731616114005	Aswinkumar S	41
6	731616114006	Bharath V	45
7	731616114007	Boopathi Raja E	39
8	731616114008	Boopathy K M	41
9	731616114009	Chandrasekar K	42
10	731616114010	Chellathurai T	41
11	731616114011	Deepak R	45
12	731616114012	Dhayanidhi M	40
13	731616114015	Dinesh Kumar C	45
14	731616114016	Gokul R	46
15	731616114017	Gokulraj P	42
16	731616114018	Gopinath G	45
17	731616114019	Govindasamy A	46
18	731616114020	Gowtham P	42
19	731616114021	Gunasekaran R	41
20	731616114022	Hariharan M	38
21	731616114023	Hariharan S	39
22	731616114024	Hari Shankar P	48
23	731616114025	Inbarasan C	47
24	731616114027	Jayamurugan K S	44
25	731616114028	Jeeva K	39
26	731616114029	Jeeva M	41
27	731616114030	Jestinraj K	36
28	731616114031	Joshua Y	34
29	731616114032	Kaleeswaran D	42
30	731616114033	Karole Infanto D	30
31	731616114034	Karthikeyan P	32
32	731616114035	Kavin P	41
33	731616114036	Kavinkumar R	44
34	731616114037	Keerthivasan S	40
35	731616114038	Kesav Goutham N B	34
36	731616114040	Kirubakaran M	46
37	731616114041	Lakshmi Narayanan R	43
38	731616114042	Logesh N	42
39	731616114043	Logesh S	40
40	731616114044	Madhankumar L	38
41	731616114045	Mageswaran A	49
42	731616114046	Manikandan V	45
43	731616114047	Manojkumar K	49
44	731616114048	Mohammed Nihal R	48
45	731616114049	Mohanakrishnan D	45
46	731616114050	Mohan Arjun Kumaravel	41
47	731616114051	Mohanraj B	39

  
Dr. M. VENKATESAN, M.E., Ph.D.,  
PRINCIPAL,  
K S R INSTITUTE FOR  
ENGINEERING AND TECHNOLOGY,  
K.S.R. KALVI NAGAR,  
TIRUCHENGODE-637 215,  
NAMAKKAL DT, TAMIL NADU



S.NO	REG.NO	NAME OF THE STUDENT	Marks(50)
48	731616114052	Nambiraj J	40
49	731616114053	Nandhagobal S	42
50	731616114057	Prabhakaran M	45
51	731616114058	Prasanth R	41
52	731616114059	Praveen R (07-01-1999)	39
53	731616114060	Praveen R (31-03-1999)	48
54	731616114061	Praveenkumar S	47
55	731616114062	Prem Kumar K R	44
56	731616114063	Ragavendhar S	37
57	731616114064	Rahul C	42
58	731616114065	Rajkumar S	41
59	731616114066	Ranjith R	45
60	731616114067	Ranjithkumar R	41
61	731616114068	Ranjith Kumar V	40
62	731616114069	Ravichandran S	38
63	731616114070	Riyaz Ahamed S	46
64	731616114071	Ruthrannan B	42
65	731616114072	Sabarish R	40
66	731616114073	Sakthi Gnanasundaram R H	41
67	731616114074	Sakthivel R	43
68	731616114075	Sanjay Kumar S	46
69	731616114076	Sanjay Kumar S K	42
70	731616114077	Santhoshkumar B	40
71	731616114078	Santhoshkumar V	49
72	731616114079	Saran K	48
73	731616114080	Saranraj S	45
74	731616114081	Sathish G	40
75	731616114082	Shakthi R M	42
76	731616114083	Sowndhar A	37
77	731616114086	Thamotharan J	35
78	731616114087	Thirumurugan V	43
79	731616114088	Uthaya Kumar M	31
80	731616114089	Vasanth S	33
81	731616114090	Vasantha Kumar P	42
82	731616114091	Velmurugan T	45
83	731616114092	Vignesh B	41
84	731616114093	Vignesh V	35
85	731616114094	Vijay Anand G	47
86	731616114095	Vijayaragavan P	44
87	731616114096	Vinothmani M	43
88	731616114097	Vishnu A	41
89	731616114098	Vivek P	39
90	731616114099	Yogaraj G	50
91	731616114100	Yogesh T	46
92	731616114302	balaji M	50
93	731616114303	Barath V	49
94	731616114304	Ethayakumar G	46
95	731616114305	Jeevanandham N	42
96	731616114306	Karthi S	40
97	731616114307	PRAKSAH.S	41
98	731616114310	SHANMUGA MANIVEL	43
99	731616114311	SURENDHARAN.J	46
Course Coordinator			
HoD			

  
 Dr. M. VENKATESAN, M.E., Ph.D  
 PRINCIPAL,  
 K S R INSTITUTE FOR  
 ENGINEERING AND TECHNOLOGY  
 K.S.R. KALVI NAGAR,  
 TIRUCHENGODE-637 215,  
 NAMAKKAL Dt, TAMIL NADU.

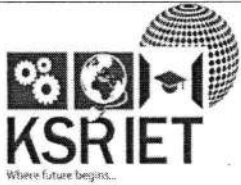

**K S R INSTITUTE FOR ENGINEERING AND TECHNOLOGY**

**Tiruchengode, Namakkal – 637215**

**Department of Mechanical Engineering**

**Value Added Course - AutoCAD**

**Date : 11/08/2017**

**FEEDBACK FORM**

**Tick the Appropriate Columns:**

Parameter	Excellent	Very Good	Good	Satisfactory
Content Delivered	✓			
Registration		✓		
Program Management	✓			
Hospitality	✓			
About Campus	✓			

**Participant Name:** *K. Jeeva*

**Suggestions for Improvement:**

*K. Jeeva*  
**Signature of the Participant**

  
**Dr. M. VENKATESAN, M.E., Ph.D.,**  
**PRINCIPAL,**  
**K S R INSTITUTE FOR**  
**ENGINEERING AND TECHNOLOGY,**  
**K.S.R. KALVI NAGAR,**  
**TIRUCHENGODE-637 215,**  
**NAMAKKAL Dt, TAMIL NADU.**



**K S R INSTITUTE FOR ENGINEERING AND TECHNOLOGY**

**Tiruchengode, Namakkal – 637215,**

**Department of Mechanical Engineering**

**Value Added Course - AutoCAD**

**Date : 11/08/2017**

**FEEDBACK FORM**

**Tick the Appropriate Columns:**

Parameter	Excellent	Very Good	Good	Satisfactory
Content Delivered	✓			
Registration		✓		
Program Management	✓			
Hospitality		✓		
About Campus	✓			

**Participant Name:** Gokul R

**Suggestions for Improvement:**

*Gokul R*  
**Signature of the Participant**

  
**Dr., M. VENKATESAN, M.E., Ph.D.,**  
PRINCIPAL,  
K S R INSTITUTE FOR  
ENGINEERING AND TECHNOLOGY  
K.S.R. KALVI NAGAR,  
TIRUCHENGODE-637 215,  
NAMAKKAL Dt, TAMIL NADU.

# K S R INSTITUTE FOR ENGINEERING AND TECHNOLOGY

TIRUCHENGODE – 637 215

## DEPARTMENT OF MECHANICAL ENGINEERING

### VALUE ADDED / SHORT TERM COURSE – SUMMARY

Academic Year: 2017-2018 (ODD)

<b>Name of the course</b>	Value Added / Short Term course on AUTOCAD
<b>Course Contents</b>	➤ <b>Enclosed</b>
<b>Course Outcomes</b>	<ul style="list-style-type: none"><li>➤ Evaluate mechanical designs and select the proper process and materials for production.</li><li>➤ Create 2D and 3D computer drawings and models for manufacturing and prototyping.</li><li>➤ Evaluate computer aided design models and assemblies based on critical thinking and problem solving skills.</li><li>➤ Collaborate with people of diverse backgrounds and abilities.</li><li>➤ Develop a solution through group work.</li><li>➤ Communicate and present ideas and solutions to design problems.</li></ul>
<b>Program Outcomes &amp; Program Specific Outcomes</b>	PO1,PO3,PO4,PO5,PO6,PO9,P10,PO12, PSO2
<b>Course Convener</b>	Dr.P.Murugesan,HoD/MECH
<b>Course Coordinators</b>	Mr.A.V.T SHUBHASH AP/MECH
<b>Resource Persons</b>	Mr.L.Selvakumar (United cad) Mr.M.kannan (United cad) Mr.S.Baskaran AP/MECH Mr.D.Ramkumar AP/MECH
<b>Duration &amp; Dates</b>	38 Hours & 10/07/17 To 11/08/17
<b>Participants &amp; Strength</b>	II YEAR MECH KSRIET STUDENTS & 99

  
Coordinator

  
Convener

  
Dr. M. VENKATESAN, M.E., Ph.D.,  
PRINCIPAL,  
K S R INSTITUTE FOR  
ENGINEERING AND TECHNOLOGY,  
K.S.R. KALVI NAGAR,  
TIRUCHENGODE-637 215,  
NAMAKKAL Dt, TAMIL NADU.

**KSR INSTITUTE FOR ENGINEERING AND TECHNOLOGY  
DEPARTMENT OF MECHANICAL ENGINEERING  
CENTRE FOR VALUE ADDED EDUCATION (CENVAE)**

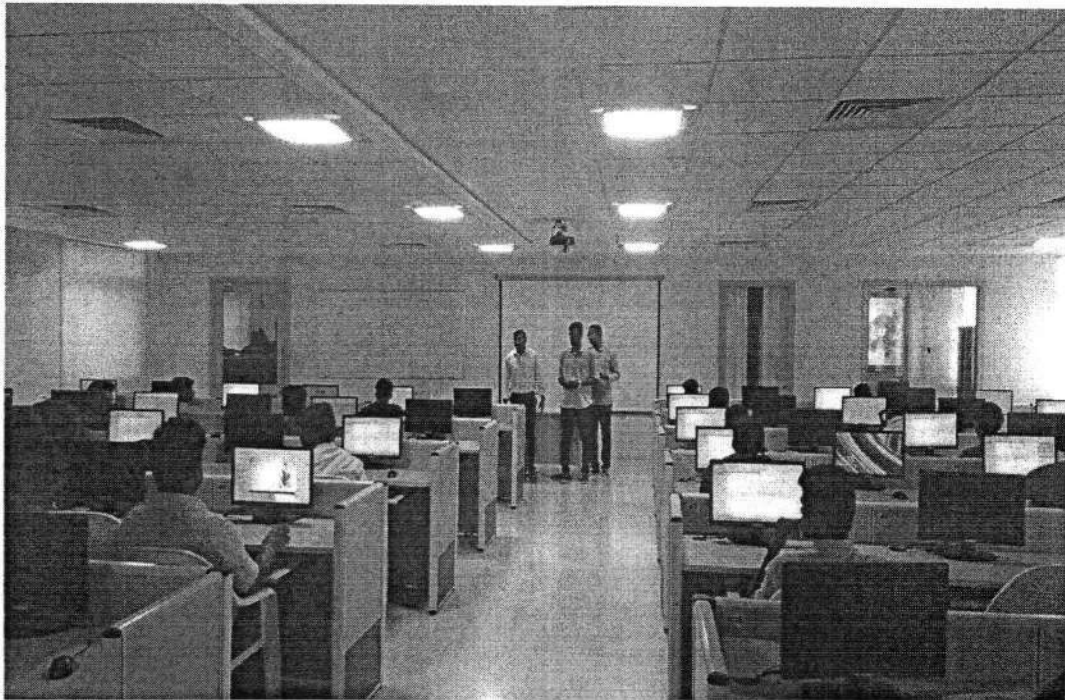

**VALUE ADDED COUSE AUTOCAD II YEAR**

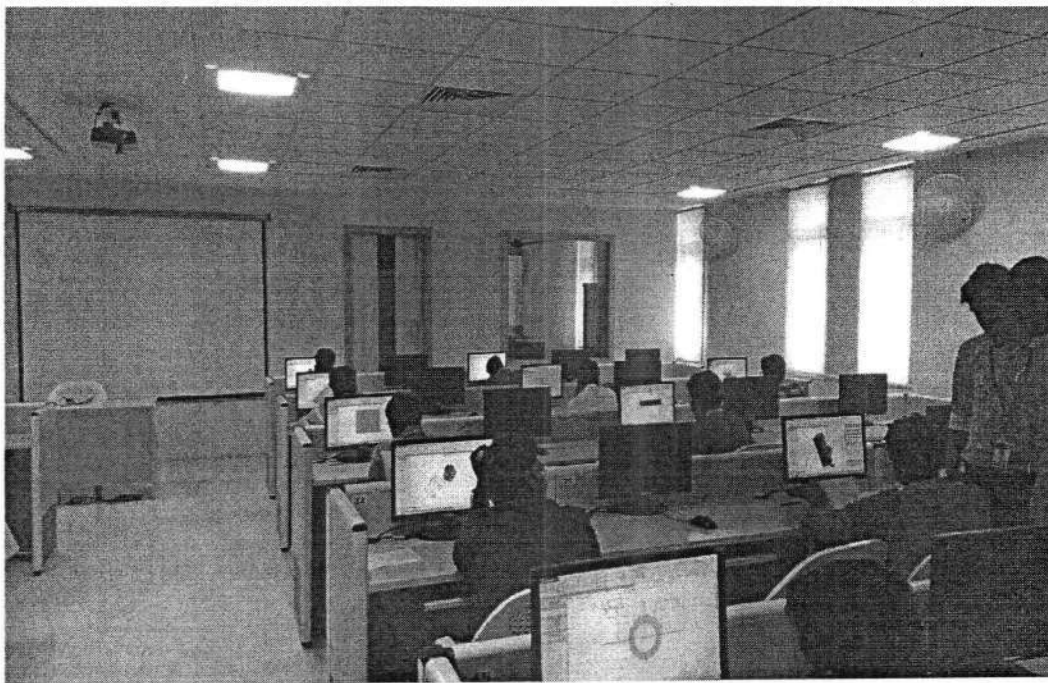

**VALUE ADDED COUSE AUTOCAD II YEAR**

  
Dr. M. VENKATESAN, M.E., Ph.D.,  
PRINCIPAL,  
K S R INSTITUTE FOR  
ENGINEERING AND TECHNOLOGY,  
K.S.R. KALVI NAGAR,  
TIRUCHENGODE-637 215,  
NAMAKKAL DI, TAMIL NADU.



# K S R INSTITUTE FOR ENGINEERING & TECHNOLOGY, TIRUCHENGODE

(APPROVED BY AICTE, NEW DELHI AND AFFILIATED TO ANNA UNIVERSITY, CHENNAI)

## DEPARTMENT OF MECHANICAL ENGINEERING CENTRE FOR VALUE ADDED EDUCATION (CENVAE)

### VALUE ADDED COURSE AUTOCAD

#### CERTIFICATE OF PARTICIPATION

This is to certify that Mr. /Ms. P. KAVIN of II-YEAR  
Department of Mechanical Engineering, K S R INSTITUTE FOR  
ENGINEERING AND TECHNOLOGY has attended value added course on  
“AUTOCAD” organized by the Department of Mechanical Engineering,  
K S R IET from 10/07/17 to 11/08/17.

  
COURSE COORDINATOR

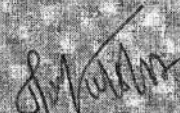
  
HOD



  
PRINCIPAL



**K S R INSTITUTE FOR ENGINEERING AND TECHNOLOGY**  
**Tiruchengode, Namakkal – 637215**

**Department of Mechanical Engineering**

**Value Added Course – Syllabus**

The course covers the topics you need to review for the CREO FOR INDUSTRIAL DESIGN for design including:

- Module 1: INTRODUCTION TO CREO PARAMETRIC** 7  
Introduction to Creo Parametric Feature-Based Nature Bidirectional Associative Property Parametric Nature System Requirements Getting Started with Creo Parametric- Important Terms and Definitions File Menu Options- Managing Files- Menu Manager Model Tree -Understanding the Functions of the Mouse Buttons- Ribbon Toolbars Navigator
- Module 2: CREATING SKETCHES IN THE SKETCH MODE** 8  
The Sketcher Environment-Working with a Sketch in the Sketch Mode-Drawing a Sketch Using tools available in the Sketch Tab-Dimensioning the Sketch-Dimensioning the Basic Sketched Entities-Working with Constraints-Resolve Sketch Dialog Box- Deleting the Sketched Entities - Trimming the Sketched Entities- Mirroring the Sketched Entities.
- Module 3: OPTIONS AIDING CONSTRUCTION OF PARTS** 8  
Options Aiding Construction of Parts-Creating Holes-Creating Rounds-Creating Chamfers-Understanding Ribs-Editing Features of a Model-Creating Feature Patterns-Copying Features- Mirroring a Geometry-Creating a Section of a Solid Model
- Module 4: ASSEMBLY MODELING** 9  
Assembly Modelling -Important Terms Related to the Assembly Mode-Creating Top-down Assemblies-Creating Bottom-up Assemblies-Assembling Components-Modifying the Components of an Assembly-Creating the Exploded State
- Module 5: SURFACE MODELING** 10  
Surface Modelling-Creating Surfaces in Creo Parametric-Creating Surfaces the Using the Style Environment of Creo Parametric-Surface Editing Tools Mirroring-Freestyle modelling environment- Invoking the Sheet metal Mode-Introduction to Sheet metal Walls-Creating the Bend Feature Creating the Unbend Feature

  
COORDINATOR

  
**Dr., M. VENKATESAN, M.E., Ph.D.,**  
PRINCIPAL,  
K S R INSTITUTE FOR  
ENGINEERING AND TECHNOLOGY,  
K.S.R. KALVI NAGAR,  
TIRUCHENGODE-637 215,  
NAMAKKAL Dt, TAMIL NADU.

**Total: 43 Hours**



**K S R INSTITUTE FOR ENGINEERING AND TECHNOLOGY**  
Tiruchengode, Namakkal – 637215

**Department of Mechanical Engineering**

## **Five Days Value Added Course – CREO FOR INDUSTRIAL DESIGN**

### **Schedule**

Date: 25/05/2017

S.No.	Date	Topic	Name of the Faculty
1.	29/05/2017	Introduction to Creo Parametric Feature-Based Nature Bidirectional Associative Property Parametric Nature System Requirements Getting Started with Creo Parametric- Important Terms and Definitions File Menu Options- Managing Files- Menu Manager Model Tree - Understanding the Functions of the Mouse Buttons- Ribbon Toolbars Navigator	Mr.K.Gopalakrishnan& Mr.M.V.Shanmugam
2.	30/05/2017	The Sketcher Environment-Working with a Sketch in the Sketch Mode-Drawing a Sketch Using tools available in the Sketch Tab-Dimensioning the Sketch-Dimensioning the Basic Sketched Entities-Working with Constraints-Resolve Sketch Dialog Box- Deleting the Sketched Entities - Trimming the Sketched Entities- Mirroring the Sketched Entities.	Mr.K.Vijay& Mr.A.M.Ramkumar
3.	31/05/2017	Options Aiding Construction of Parts-Creating Holes-Creating Rounds-Creating Chamfers-Understanding Ribs-Editing Features of a Model-Creating Feature Patterns-Copying Features-Mirroring a Geometry-Creating a Section of a Solid Model	Mr.K.Gopalakrishnan& Mr.M.V.Shanmugam
4.	01/06/2017	Assembly Modelling -Important Terms Related to the Assembly Mode-Creating Top-down Assemblies-Creating Bottom-up Assemblies-Assembling Components-Modifying the Components of an Assembly-Creating the Exploded State	Mr.K.Vijay& Mr.A.M.Ramkumar
5.	02/06/2017	Surface Modelling-Creating Surfaces in Creo Parametric-Creating Surfaces the Using the Style Environment of Creo Parametric-Surface Editing Tools Mirroring-Freestyle modelling environment-Invoking the Sheet metal Mode-Introduction to Sheet metal Walls-Creating the Bend Feature Creating the Unbend Feature	Mr.K.Gopalakrishnan& Mr.M.V.Shanmugam

Faculty Incharge

Dr., M. VENKATESAN, M.E., Ph.D.,  
PRINCIPAL,  
K S R INSTITUTE FOR  
ENGINEERING AND TECHNOLOGY,  
K.S.R. KALVI NAGAR,  
TIRUCHENGODE-637 215,  
NAMAKKAL Dt, TAMIL NADU.

HOD



**K S R Institute for Engineering and Technology**  
**Department of Mechanical Engineering**  
**Value Added Course on Cero for Industrial Design**

Year: III

Attendance

Academic Year:2017-18

S.NO	REG.NO	NAME OF THE STUDENT	29.05.17	30.05.17	31.05.17	01.06.17	02.06.17
1	731615114003	AJITH V	/	/	/	/	/
2	731615114004	AJITHKUMAR S	/	/	/	/	/
3	731615114005	AJITH KUMAR S	/	/	/	A	/
4	731615114006	AKILAN M	/	A	/	/	/
5	731615114008	ARAVINDH P	/	/	/	/	/
6	731615114011	ARUN KUMAR S	/	/	/	/	/
7	731615114012	ASHWIN L	/	/	/	/	/
8	731615114013	BALACHANDARAN S	/	/	/	/	/
9	731615114018	BALAKUMAR A	/	/	/	/	/
10	731615114019	BENAZIR U	/	/	A	/	/
11	731615114022	BHARATH KUMAR S	/	/	/	/	/
12	731615114023	BHUVANESHWARAN S	/	/	/	/	/
13	731615114024	BOOPATHIRAJA S	/	A	/	/	/
14	731615114030	DHANUSH R	/	/	/	/	/
15	731615114031	DHARANISHANKAR P	/	/	/	/	/
16	731615114032	DHINESH S	/	/	/	A	/
17	731615114033	DHINESHRAJ L	/	/	/	/	/
18	731615114034	DINESH J	/	/	/	/	A
19	731615114036	DINESH V	/	/	/	/	/
20	731615114037	DINESHKUMAR B	/	/	/	/	/
21	731615114038	DINESHKUMAR T	/	/	/	/	/
22	731615114039	DUDIARASU S	/	A	/	/	/
23	731615114041	ELANTHENDRAL R M	/	/	/	/	/
24	731615114042	GABY SACHIN S	/	/	/	/	/
25	731615114045	GNANA PRAKASH A S	/	/	/	/	/
26	731615114046	GOBINATH R	/	/	A	/	/
27	731615114047	GOKUL P	/	/	/	/	/
28	731615114049	GOKULRAJ V	/	/	/	/	/
29	731615114050	GOPIKA R	/	/	/	A	/
30	731615114053	HARIRAJ K	/	/	/	/	/
31	731615114054	HRITHWIK RAJEEV	/	/	/	/	/
32	731615114056	JAGADEESH S	/	/	A	/	/
33	731615114057	JAGADEESHBABU K	/	/	/	/	/
34	731615114058	JAGADESHWARAN S	/	/	/	/	/
35	731615114060	KABIL L	/	A	/	/	/
36	731615114061	KANNAN P	/	/	/	/	/
37	731615114062	KARTHICK R	/	/	/	/	/
38	731615114066	KAVIPRIYAN S	/	/	/	/	/
39	731615114071	LINGESWAR M	/	/	/	/	/
40	731615114072	LOGANATHAN K	/	/	/	/	/
41	731615114073	MADHAN KUMAR M	/	/	/	/	/
42	731615114074	MADHUSUDHAN R	/	/	/	/	/
43	731615114075	MANIKANDABOOPATHI B	/	/	/	/	/
44	731615114077	MANIKANDAN P	/	/	/	/	/
45	731615114078	MANIKANDAN S	/	/	/	/	/
46	731615114080	MANOJKUMAR P R	/	/	/	/	/
47	731615114081	MANOKARAN P	A	/	/	/	A
48	731615114086	NANDHAKUMAR M	/	/	/	/	/
49	731615114087	NANDHAKUMAR.S (6/10/97)	/	/	/	/	/
50	731615114088	NANDHAKUMAR S (22/8/98)	/	/	/	/	/

Dr. M. VENKATESAN, M.E., Ph.D.,

PRINCIPAL,

K S R INSTITUTE FOR  
ENGINEERING AND TECHNOLOGY,

K.S.R. VALVINAGAR,

TIRUCHENGODE-637 215.

S.NO	REG.NO	NAME OF THE STUDENT	29.05.17	30.05.17	31.05.17	01.06.17	02.06.17
51	731615114090	NAVANEETHAN R	/	/	/	/	/
52	731615114091	NAVEEN M (20/3/97)	/	/	/	/	/
53	731615114092	NAVEEN M (20/6/97)	/	/	A	/	/
54	731615114093	NAVEEN N	/	/	/	/	/
55	731615114094	NAVEENKUMAR B	/	/	/	/	/
56	731615114095	NAVEEN KUMAR N (6.1.97)	/	/	/	/	/
57	731615114102	PRAKASH R	/	A	/	/	/
58	731615114103	PRASANNAKUMAR M	/	/	/	/	/
59	731615114104	PRAVEEN R	/	/	/	/	A
60	731615114105	PRINSHITH P	/	/	/	/	/
61	731615114106	PRITAM BHATTACHARYA G	/	/	/	/	/
62	731615114107	PUGAZHENDI S K	A	/	/	/	/
63	731615114108	PUVIYARASAN N	/	/	/	/	/
64	731615114111	RAMANA SARATHI A T	/	/	A	/	/
65	731615114112	RAMESH M	/	/	/	/	/
66	731615114305	DINESH S	/	/	/	/	/
67	731615114308	GOWTHAM V	/	/	/	/	A
68	731615114309	KARTHIK G	/	/	/	/	/
69	731615114312	MAHESWARAN K	/	/	/	/	/
70	731615114117	SAI HARISH V	/	/	/	/	/
71	731615114118	SAMUEL DURAI A	/	/	/	/	/
72	731615114119	SANJAYKUMAR A	/	/	/	/	/
73	731615114121	SANTHOSHKUMAR S	/	/	/	/	/
74	731615114122	SANTHOSH KUMAR M	A	/	/	/	/
75	731615114126	SASIKUMAR S (02.03.1998)	/	/	/	/	/
76	731615114128	SATHISHKUMAR S	/	/	/	/	A
77	731615114129	SATHISH KUMAR T	/	/	/	/	/
78	731615114132	SHANKAR A	/	A	/	/	/
79	731615114133	SHANKAR K	/	/	/	/	/
80	731615114138	SOUNDHIRARAJAN P	/	/	/	A	/
81	731615114139	SRIDHAR L	/	/	/	/	/
82	731615114143	SUGAN A	/	/	/	/	/
83	731615114148	TAMILVANAN M	/	A	/	/	/
84	731615114149	THAGAPPILLAI G	/	/	/	/	/
85	731615114153	VASANTHAKUMAR B	/	/	/	/	/
86	731615114155	VENGAINAYAGAN K	A	/	/	/	A
87	731615114159	VIGNESH S (20.03.1997)	/	/	/	/	/
88	731615114313	NAVEEN A	/	/	/	/	/
89	731615114319	REVENTHKUMAR S	/	/	/	A	/
90	731615114320	SARANKUMAR R	/	/	/	/	/
91	731615114322	SUNILRAJ C	/	/	A	/	/
92	731615114701	NAVANEETHAKRISHNAN M	/	/	/	/	/
Course Coordinator			/	/	/	/	/
HoD			/	/	/	/	/

  
 Dr. M. VENKATESAN, M.E., Ph.D.,  
 PRINCIPAL,  
 K S R INSTITUTE FOR  
 ENGINEERING AND TECHNOLOGY,  
 K.S.R. KALVI NAGAR,  
 TIRUCHENGODE-637 215,  
 NAMAKKAL Dt, TAMIL NADU.

KSR INSTITUTE FOR ENGINEERING AND TECHNOLOGY  
DEPARTMENT OF MECH ANICAL ENGINEERING  
Centre of value added education  
Assessment Test  
CREO FOR INDUSTRIAL DESIGN

Date: 2.06.17  
Mark =50

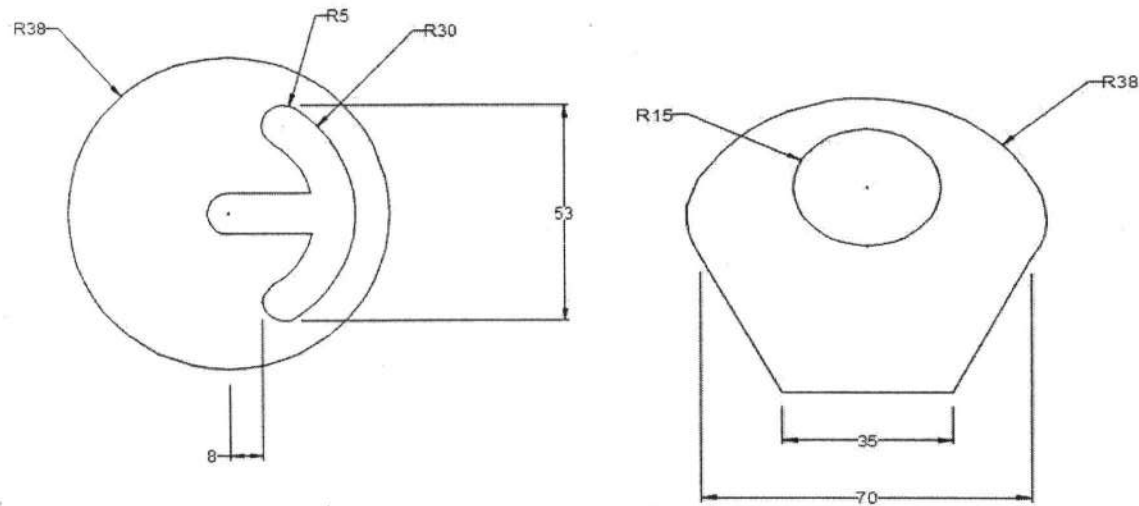

ALL DIMENSIONS ARE IN MM

DR. M. VENKATESAN, M.E. Ph.D.  
PRINCIPAL,  
K S R INSTITUTE FOR  
ENGINEERING AND TECHNOLOGY,  
K.S.R. KALVI NAGAR,  
TIRUCHENGODE-637 215,  
NAMAKKAL Dt, TAMIL NADU.

COURSE COORDINATOR



HOD 2/6/17

**K S R Institute for Engineering and Technology**  
**Department of Mechanical Engineering**  
**Value Added Course on Creo Industrial Design**

Year:III      Assessment Mark    Academic Year:2017-18

S.NO	REG.NO	NAME OF THE STUDENT	Marks(50)
1	731615114003	AJITH V	43
2	731615114004	AJITHKUMAR S	39
3	731615114005	AJITH KUMAR S	37
4	731615114006	AKILAN M	38
5	731615114008	ARAVINDH P	40
6	731615114011	ARUN KUMAR S	43
7	731615114012	ASHWIN L	39
8	731615114013	BALACHANDARAN S	37
9	731615114018	BALAKUMAR A	42
10	731615114019	BENAZIR U	37
11	731615114022	BHARATH KUMAR S	39
12	731615114023	BHUVANESHWARAN S	34
13	731615114024	BOOPATHIRAJA S	32
14	731615114030	DHANUSH R	40
15	731615114031	DHARANISHANKAR P	28
16	731615114032	DHINESH S	30
17	731615114033	DHINESHRAJ L	39
18	731615114034	DINESH J	42
19	731615114036	DINESH V	38
20	731615114037	DINESHKUMAR B	32
21	731615114038	DINESHKUMAR T	44
22	731615114039	DUDIARASU S	41
23	731615114041	ELANTHENDRAL R M	40
24	731615114042	GABY SACHIN S	38
25	731615114045	GNANA PRAKASH A S	36
26	731615114046	GOBINATH R	47
27	731615114047	GOKUL P	43
28	731615114049	GOKULRAJ V	47
29	731615114050	GOPIKA R	46
30	731615114053	HARIRAJ K	43
31	731615114054	HRITHWIK RAJEEV	39
32	731615114056	JAGADEESH S	37
33	731615114057	JAGADEESHBABU K	38
34	731615114058	JAGADESHWARAN S	40
35	731615114060	KABIL L	43
36	731615114061	KANNAN P	39
37	731615114062	KARTHICK R	37
38	731615114066	KAVIPRIYAN S	46
39	731615114071	LINGESWAR M	35
40	731615114072	LOGANATHAN K	40
41	731615114073	MADHAN KUMAR M	39
42	731615114074	MADHUSUDHAN R	43
43	731615114075	MANIKANDABOOPATHI B	39
44	731615114077	MANIKANDAN P	38
45	731615114078	MANIKANDAN S	36
46	731615114080	MANOJKUMAR P R	44
47	731615114081	MANOKARAN P	40
48	731615114086	NANDHAKUMAR M	38
49	731615114087	NANDHAKUMAR.S (6/10/97)	39
50	731615114088	NANDHAKUMAR S (22/8/98)	41

  
**Dr., M. VENKATESAN, M.E., Ph.D.,**  
 PRINCIPAL,  
 K.S.R INSTITUTE FOR  
 ENGINEERING AND TECHNOLOGY,  
 K.S.R. KALVI NAGAR,  
 TIRUCHENGODE-637 215,  
 TAMIL NADU.

S.NO	REG.NO	NAME OF THE STUDENT	Marks(50)
51	731615114090	NAVANEETHAN R	44
52	731615114091	NAVEEN M (20/3/97)	40
53	731615114092	NAVEEN M (20/6/97)	38
54	731615114093	NAVEEN N	47
55	731615114094	NAVEENKUMAR B	46
56	731615114095	NAVEEN KUMAR N (6.1.97)	43
57	731615114102	PRAKASH R	38
58	731615114103	PRASANNAKUMAR M	40
59	731615114104	PRAVEEN R	35
60	731615114105	PRINSHITH P	33
61	731615114106	PRITAM BHATTACHARYA G	41
62	731615114107	PUGAZHENDI S K	29
63	731615114108	PUVIYARASAN N	31
64	731615114111	RAMANA SARATHI A T	40
65	731615114112	RAMESH M	43
66	731615114305	DINESH S	45
67	731615114308	GOWTHAM V	42
68	731615114309	KARTHIK G	41
69	731615114312	MAHESWARAN K	39
70	731615114117	SAI HARISH V	37
71	731615114118	SAMUEL DURAI A	48
72	731615114119	SANJAYKUMAR A	44
73	731615114121	SANTHOSHKUMAR S	48
74	731615114122	SANTHOSH KUMAR M	47
75	731615114126	SASIKUMAR S (02.03.1998)	44
76	731615114128	SATHISHKUMAR S	41
77	731615114129	SATHISH KUMAR T	39
78	731615114132	SHANKAR A	37
79	731615114133	SHANKAR K	48
80	731615114138	SOUNDHIRARAJAN P	44
81	731615114139	SRIDHAR L	48
82	731615114143	SUGAN A	47
83	731615114148	TAMILVANAN M	44
84	731615114149	THAGAPPILLAI G	41
85	731615114153	VASANTHAKUMAR B	39
86	731615114155	VENGAINAYAGAN K	41
87	731615114159	VIGNESH S (20.03.1997)	44
88	731615114313	NAVEEN A	37
89	731615114319	REVENTHKUMAR S	48
90	731615114320	SARANKUMAR R	44
91	731615114322	SUNILRAJ C	48
92	731615114701	NAVANEETHAKRISHNAN M	44
Course Coordinator			
HoD			

  
 UTM Y.P. VISWANATHAN, M.E., Ph.D.,  
 P. O. Box 100,  
 ENGINEERING AND TECHNOLOGY,  
 K.S.R. KALVINAGAR,  
 MUDICHENGODE-637 215,  
 TAMARAIKAL DI, TAMIL NADU.

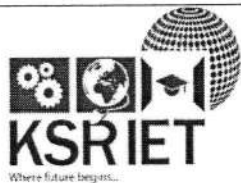

**K S R INSTITUTE FOR ENGINEERING AND TECHNOLOGY**  
Tiruchengode, Namakkal – 637215

**Department of Mechanical Engineering**

**Value Added Course - Creo for Industrial Design**

**Date: 03/06/2017**

**FEEDBACK FORM**

**Tick the Appropriate Columns:**

Parameter	Excellent	Very Good	Good	Satisfactory
Content Delivered	/			
Registration	/			
Program Management	/			
Hospitality	/			
About Campus	/			

**Participant Name:** A. SUGAN

**Suggestions for Improvement:**

  
Dr. M. VENKATESAN, M.E., Ph.D.,  
PRINCIPAL,  
K S R INSTITUTE FOR  
ENGINEERING AND TECHNOLOGY,  
K.S.R. KALVI NAGAR,  
TIRUCHENGODE-637 215,  
NAMAKKAL Dt, TAMIL NADU.

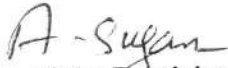
  
Signature of the Participant



**K S R INSTITUTE FOR ENGINEERING AND TECHNOLOGY**  
Tiruchengode, Namakkal – 637215

**Department of Mechanical Engineering**

**Value Added Course - Creo for Industrial Design**

Date: 03/06/2017

**FEEDBACK FORM**

**Tick the Appropriate Columns:**

Parameter	Excellent	Very Good	Good	Satisfactory
Content Delivered			✓	
Registration	✓			
Program Management	✓	✓		
Hospitality		✓		
About Campus	✓			

**Participant Name:**

Sunil Raj C

**Suggestions for Improvement:**

  
Dr. M. VENKATESAN, M.E., Ph.D.,  
PRINCIPAL,  
K S R INSTITUTE FOR  
ENGINEERING AND TECHNOLOGY  
K.S.R. KALVI NAGAR,  
TIRUCHENGODE-637 215,  
NAMAKKAL Dt, TAMIL NADU.

  
**Signature of the Participant**

# K S R INSTITUTE FOR ENGINEERING AND TECHNOLOGY

TIRUCHENGODE – 637 215

## DEPARTMENT OF MECHANICAL ENGINEERING

### VALUE ADDED / SHORT TERM COURSE – SUMMARY

Academic Year: 2017-18 (ODD)

<b>Name of the course</b>	Five days Value Added / Short Term course on Creo for Industrial Design
<b>Course Contents</b>	➤ <b>Enclosed</b>
<b>Course Outcomes</b>	<ul style="list-style-type: none"><li>• Students will learn how to sketch, model, validate design and visualize product design using the software</li><li>• Students will be able to do direct drafting, direct modelling and parametric 3D modelling.</li><li>• Students will know how to validate your product design according to the given requirement.</li><li>• This is a Ready-for-Industry course which gives the students ample knowledge to ace the placement drive.</li></ul>
<b>Program Outcomes &amp; Program Specific Outcomes</b>	PO1,PO3,PO4,PO5,PO6,PO9,P10,PO12,PSO2
<b>Course Convener</b>	Dr.P.MURUGESAN, HoD/MECH
<b>Course Coordinators</b>	Mr.A.V.T SHUBHASH AP/MECH
<b>Resource Persons</b>	Mr.K.Gopalakrishnan AP/MECH Mr.M.V.Shanmugam AP/MECH Mr.K.Vijay AP/MECH Mr.A.M.Ramkumar AP/MECH
<b>Duration &amp; Dates</b>	Five days (43 Hours) & 29/05/2017 to 02/06/2017
<b>Participants &amp; Strength</b>	III YEAR MECH KSRIET STUDENTS & 92

  
**Coordinator**



  
**Convener**

Dr. M. VENKATESAN, M.E., Ph.D.  
PRINCIPAL  
K S R INSTITUTE FOR  
ENGINEERING AND TECHNOLOGY,  
K.S.R. KAMINAR,  
TIRUCHENGODE 637 215,  
NAMAKKAL Dt, TAMIL NADU.



**KSR INSTITUTE FOR ENGINEERING AND TECHNOLOGY  
DEPARTMENT OF MECHANICAL ENGINEERING  
CENTRE FOR VALUE ADDED EDUCATION (CENVAE)**



**VALUE ADDED COUSE FOR CERO - INDUSTRIAL DESIGN**



**VALUE ADDED COUSE FOR CERO INDUSTRIAL DESIGN**

**Dr. M. VENKATESAN, M.E., Ph.D.,  
PRINCIPAL,  
K S R INSTITUTE FOR  
ENGINEERING AND TECHNOLOGY,  
K.S.R. KALVI NAGAR,  
TIRUCHENGODE-637 215,  
NAMAKKAL Dt, TAMIL NADU.**

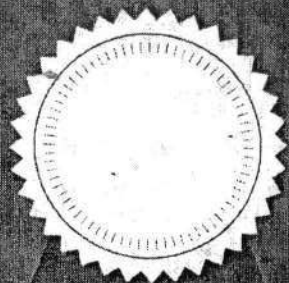

# K S R INSTITUTE FOR ENGINEERING & TECHNOLOGY

(APPROVED BY AICTE, NEW DELHI AND AFFILIATED TO ANNA UNIVERSITY, CHENNAI)

## DEPARTMENT OF MECHANICAL ENGINEERING

CENTRE FOR VALUE ADDED EDUCATION (CENVAE)

VALUE ADDED COURSE CREO FOR INDUSTRIAL DESIGN

### *Certificate of Participation*

This is to certify that Mr. /Ms. A. SUGAN  
of III - YEAR, Department of Mechanical Engineering,  
K S R INSTITUTE FOR ENGINEERING AND TECHNOLOGY  
has attended value added course on "Creo for  
Industrial Design" organized by the Department of  
Mechanical Engineering, KSR IET. from 29/05/17 to  
02/06/17.

  
\_\_\_\_\_  
COORDINATOR

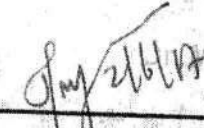
  
\_\_\_\_\_  
HOD

  
\_\_\_\_\_  
VENKATESAN, M.E., Ph.D.  
PRINCIPAL,  
K S R INSTITUTE FOR  
ENGINEERING AND TECHNOLOGY,  
K. S. R., KALVI NAGAR,  
TIRUCHENGODE-637 215,  
NAMAKKAL DISTRICT, NADU.

  
\_\_\_\_\_  
PRINCIPAL

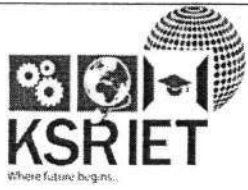

**K S R INSTITUTE FOR ENGINEERING AND TECHNOLOGY**  
**Tiruchengode, Namakkal – 637215**  
**(Accredited by NBA, Affiliated to Anna University, Chennai)**  
**Department of Mechanical Engineering**

## Value Added Course – Syllabus

The course covers the topics you need to review for the Creo for Automation and production including:

### **Module 1: Advance Part Modeling**

6

Advanced Selection Techniques - Advanced Datum Features - Advanced Sketching Techniques - Create advanced holes - Create advanced drafts and ribs - Create advanced shells - Create advanced rounds and chamfers - Use relations and parameters - Create advanced blends

### **Module 2: Assembly Design**

7

Use advanced component selection - Use advanced assembly constraints - Create and use component interfaces - Utilize intelligent fasteners Extension (IFX) - Create and use flexible components - Restructure and mirror assemblies - Use assembly features and shrink wrap - Replace components in an assembly

### **Module 3: Creo Simulation & Structural Analysis**

8

Introduction to Creo Simulate - Theoretical Foundations - Structural Mechanics - Simulation Models - Explore materials and material properties - Understand and use structural constraints - Understand and use structural loads – Meshing - Understand convergence - Run structural analyses

### **Module 4: Flexible Modeling**

9

Understand Flexible Modeling basics - Apply shape surface selection - Perform flexible transform operations on geometry - Use the various transform options - Attach and remove geometry

### **Module 5: Behavioural Modeling**

8

Apply the behavioral modeling process and concepts - Create measurement analysis features - Creating Model Property Features - Creating Analysis Features - Conducting Design Studies and Optimizing Models.

**Total: 38 Hours**

  
COORDINATOR

  
Dr. M. VENKATESAN, M.E., Ph.D.,  
PRINCIPAL,  
K S R INSTITUTE FOR  
ENGINEERING AND TECHNOLOGY,  
K.S.R. KALVI NAGAR,  
TIRUCHENGODE-637 215,  
NAMAKKAL Dt, TAMIL NADU.



**K S R INSTITUTE FOR ENGINEERING AND TECHNOLOGY**  
**Tiruchengode, Namakkal – 637215**  
**Department of Mechanical Engineering**

**Five Days Value Added Course – CREO FOR AUTOMATION AND  
PRODUCTION**

**Schedule**

**Date: 25/05/2017**

No.	Date	Topic	Name of the Faculty
1.	05/06/17	Advanced Selection Techniques - Advanced Datum Features - Advanced Sketching Techniques - Create advanced holes - Create advanced drafts and ribs - Create advanced shells - Create advanced rounds and chamfers - Use relations and parameters - Create advanced blends	Mr.G.Gowrisankar & Mr.R.Nirmalraja
2.	06/06/17	Use advanced component selection - Use advanced assembly constraints - Create and use component interfaces - Utilize intelligent fasteners Extension (IFX) - Create and use flexible components - Restructure and mirror assemblies - Use assembly features and shrink wrap - Replace components in an assembly	Mr.R.Nirmalraja & Mr.A.V.T.Shubhash
3.	07/06/17	Introduction to Creo Simulate - Theoretical Foundations - Structural Mechanics - Simulation Models - Explore materials and material properties - Understand and use structural constraints - Understand and use structural loads - Meshing - Understand convergence - Run structural analyses	Mr.R.Nirmalraja & Mr.G.Gowrisankar
4.	08/06/17	Understand Flexible Modeling basics - Apply shape surface selection - Perform flexible transform operations on geometry - Use the various transform options - Attach and remove geometry	Mr.R.Nirmalraja & Mr.A.V.T.Shubhash
5.	09/06/17	Apply the behavioral modeling process and concepts - Create measurement analysis features - Creating Model Property Features - Creating Analysis Features - Conducting Design Studies and Optimizing Models.	Mr.R.Nirmalraja & Mr.G.Gowrisankar

COORDINATOR  
*[Signature]*  
25/5/17

*[Signature]*  
Dr. M. VENKATESAN, M.E., Ph.D.  
PRINCIPAL,  
K S R INSTITUTE FOR  
ENGINEERING AND TECHNOLOGY,  
K.S.R. KALVI NAGAR,  
TIRUCHENGODE-637 215,  
NAMAKKAL Dt, TAMIL NADU.

*[Signature]*  
HOD

**K S R Institute for Engineering and Technology**  
**Department of Mechanical Engineering**  
**Value Added Course on Creo for Automation And Production**

Year: IV

Attendance

Academic Year:2017-18

S.NO	REG.NO	NAME OF THE STUDENT	05.06.17	06.06.17	07.06.17	08.06.17	09.06.17
1	731614114001	ABHIRAM T	/	/	/	/	/
2	731614114002	ABISHEK E	/	/	/	/	/
3	731614114004	AJITHKUMAR M	/	/	/	/	/
4	731614114009	ARAVIND R	/	/	/	/	/
5	731614114010	ARAVIND S	A	/	/	/	/
6	731614114011	ARAVINDHAN A J	/	/	/	/	/
7	731614114012	ARAVINDHARAJ S	/	/	/	A	/
8	731614114014	ARCHANA P	/	/	/	/	/
9	731614114015	ARJUN B	/	/	/	/	/
10	731614114016	ARJUN S A	/	A	/	/	/
11	731614114019	ARUN J	/	/	/	/	/
12	731614114020	ARUNKUMAR AR	/	/	/	/	/
13	731614114022	BALACHANDRAR.M	/	/	/	/	/
14	731614114023	BALAJLL	/	/	/	/	/
15	731614114024	BARATHRAJ.M	/	/	/	/	/
16	731614114028	DEVAN . R	/	/	A	/	/
17	731614114029	DEVARAJ. N	/	/	/	/	/
18	731614114030	DHANASEKARAN A	/	/	/	/	/
19	731614114033	DINESH.S.V	/	/	/	A	/
20	731614114035	ELAMKABILAN.P	/	/	/	/	/
21	731614114037	GANESH KARTHI K M	/	/	/	/	/
22	731614114038	GOKUL KUMAR R	/	A	/	/	/
23	731614114039	GOKUL PRASATH. L	/	A	/	/	/
24	731614114042	GOWTHAM.S	/	/	/	/	/
25	731614114045	HARIHARA DHAMODARAN K	/	/	/	/	/
26	731614114048	HARIHARAN S	/	/	A	/	/
27	731614114049	HARIHARASUDAN S	/	/	/	/	A
28	731614114050	HARISH V	/	/	/	/	/
29	731614114053	JAGAN BABU S	/	/	/	/	/
30	731614114054	JAYAPRAKASH R	/	/	/	/	/
31	731614114055	KAMALAKANNAN V	/	/	A	/	/
32	731614114056	KANNAN M	/	/	/	/	/
33	731614114057	KARTHICK P	/	/	/	/	/
34	731614114063	KAVIN KUMAR S T	/	/	/	/	/
35	731614114064	KAVIYARASU B	/	/	/	/	/
36	731614114065	KIRUBAKARAN A Y	/	A	/	/	/
37	731614114066	KISHORKUMARAN S	/	/	/	/	/
38	731614114067	KRISHNA A M	/	/	/	/	/
39	731614114068	KUMARAN E	/	/	/	A	/
40	731614114071	LOGESH M	/	/	/	/	/
41	731614114072	LOGESHKUMAR A	A	/	/	/	/
42	731614114073	MADHANBABU R	/	/	/	/	/
43	731614114074	MAHENDRAN A	/	/	A	/	/
44	731614114075	MANOJ ARAVINTH E R	/	/	/	/	/
45	731614114077	MANOJ KUMAR R	/	/	/	/	/
46	731614114078	MATHAN KUMAR S	/	/	/	/	/
47	731614114079	MEIPRAKASH K	/	/	/	/	/
48	731614114080	MITHUN CHAKRAVARTHY G	/	/	/	/	/
49	731614114084	MOHAMEDSIRAJDHEEN A.A	/	/	A	/	/

Dr. M. VENKATESAN, M.E., Ph.D.,  
**PRINCIPAL,**  
**K S R INSTITUTE FOR**  
**ENGINEERING AND TECHNOLOGY,**  
**K.S.R. KALVI NAGAR,**  
**TIRUCHENGODE-637 215,**  
**NAMAKKAL DI, TAMIL NADU.**

S.NO	REG.NO	NAME OF THE STUDENT	05.06.17	06.06.17	07.06.17	08.06.17	09.06.17
50	731614114087	MOHAN S	/	/	/	/	/
51	731614114088	MOHAN RAJ R	/	/	/	/	/
52	731614114089	MUGILESHWARAN K	/	/	/	/	/
53	731614114090	MUHILARASU S	A	/	/	/	/
54	731614114091	MUHINTHAR S	/	/	/	/	/
55	731614114095	NAINAR MOHAMED S	/	/	/	/	/
56	731614114096	NANDHA KUMAR P	/	/	/	/	/
57	731614114097	NARESHKUMAR B	/	A	/	/	/
58	731614114100	NAVEENKUMAR K P	/	/	/	/	/
59	731614114101	NETHAJI M	/	/	/	/	/
60	731614114102	NIVASAN K	/	/	/	/	/
61	731614114104	POOVARASAN S	/	/	A	/	/
62	731614114108	PRAKASH RAJ T	/	/	/	/	/
63	731614114109	PRANESH J	/	/	/	/	/
64	731614114110	PRASANTH C	/	A	A	/	/
65	731614114112	PREMKUMAR R	/	/	/	/	/
66	731614114113	RAAJKUMAR S	/	/	/	/	/
67	731614114114	RADHAKRISHNAN S	A	/	/	/	/
68	731614114117	RAJESH M	/	/	/	A	/
69	731614114119	RAJKUMAR S	/	/	/	/	/
70	731614114120	RAMAKRISHNAN P	/	/	/	/	/
71	731614114123	RANJITH KUMAR S	/	/	/	/	/
72	731614114124	SABAREESAN M	/	/	/	/	/
73	731614114128	SAM PRAKASH S	/	A	/	/	/
74	731614114132	SARAVANA MANOJ S	/	/	/	/	/
75	731614114133	SATHISH K	/	/	/	A	/
76	731614114135	SENTHUR R	/	/	/	/	/
77	731614114136	SHIVKUMAR S	/	/	/	/	/
78	731614114142	Srinivasan P	/	/	/	/	/
79	731614114143	Sukruth B	/	/	/	/	/
80	731614114146	Surya M	/	/	A	/	/
81	731614114150	Tamilselvan S	/	/	/	/	/
82	731614114152	Thirulogasanthar K	/	/	/	/	/
83	731614114159	Venugopal V	/	/	/	A	/
84	731614114163	Vijay S	/	/	/	/	/
85	731614114166	Vijayakumar M	/	/	/	/	/
86	731614114301	Boopathi P	/	A	/	/	/
87	731614114302	Chandru N	/	/	/	/	/
88	731614114311	Jeeva S	/	/	/	A	/
89	731614114312	Kaviyarsan S	A	/	/	/	/
90	731614114316	Mudaliyar Vishnu Parasuraman	/	/	/	/	/
91	731614114317	Naveen C	/	/	/	/	/
92	731614114319	Pradeepkumar R	/	/	/	/	A
93	731614114701	Shankar Ram R	/	/	/	/	/
Course Coordinator			/	/	/	/	/
HoD			/	/	/	/	/

  
 Dr. M. VENKATESAN, M.E., Ph.D.,  
 PRINCIPAL,  
 K S R INSTITUTE FOR  
 ENGINEERING AND TECHNOLOGY,  
 K.S.R. KALVI NAGAR,  
 TIRUCHENGODE-637 215,  
 NAMAKKAL Dt, TAMIL NADU.

**K S R Institute for Engineering and Technology**  
**Department of Mechanical Engineering**  
**Value Added Course Creo for Automation And Production**

Year: IV

Assessment

Academic Year:2017-2018

S.NO	REG.NO	NAME OF THE STUDENT	Marks(50)
1	731614114001	ABHIRAM T	42
2	731614114002	ABISHEK E	38
3	731614114004	AJITHKUMAR M	36
4	731614114009	ARAVIND R	37
5	731614114010	ARAVIND S	39
6	731614114011	ARAVINDHAN A J	42
7	731614114012	ARAVINDHARAJ S	38
8	731614114014	ARCHANA P	36
9	731614114015	ARJUN B	45
10	731614114016	ARJUN S A	44
11	731614114019	ARUN J	41
12	731614114020	ARUNKUMAR AR	36
13	731614114022	BALACHANDRARM	38
14	731614114023	BALAJIL	33
15	731614114024	BARATHRAJ.M	31
16	731614114028	DEVAN . R	39
17	731614114029	DEVARAJ. N	39
18	731614114030	DHANASEKARAN A	38
19	731614114033	DINESH.S.V	38
20	731614114035	ELAMKABILAN.P	41
21	731614114037	GANESH KARTHI K M	37
22	731614114038	GOKUL KUMAR R	31
23	731614114039	GOKUL PRASATH. L	43
24	731614114042	GOWTHAM.S	39
25	731614114045	HARIHARA DHAMODARAN K	38
26	731614114048	HARIHARAN S	36
27	731614114049	HARIHARASUDAN S	34
28	731614114050	HARISH V	45
29	731614114053	JAGAN BABU S	41
30	731614114054	JAYAPRAKASH R	45
31	731614114055	KAMALAKANNAN V	44
32	731614114056	KANNAN M	41
33	731614114057	KARTHICK P	37
34	731614114063	KAVIN KUMAR S T	35
35	731614114064	KAVIYARASU B	36
36	731614114065	KIRUBAKARAN A Y	38
37	731614114066	KISHORKUMARAN S	41
38	731614114067	KRISHNA A M	37
39	731614114068	KUMARAN E	35
40	731614114071	LOGESH M	44
41	731614114072	LOGESHKUMAR A	43
42	731614114073	MADHANBABU R	40
43	731614114074	MAHENDRAN A	33
44	731614114075	MANOJ ARAVINTH E R	38
45	731614114077	MANOJ KUMAR R	37
46	731614114078	MATHAN KUMAR S	41
47	731614114079	MEIPRAKASH K	37
48	731614114080	MITHUN CHAKRAVARTHY G	36
49	731614114084	MOHAMEDSIRAJDHEEN A.A	34
50	731614114087	MOHAN S	42

  
**Dr. M. VENKATESAN, M.E., Ph.D.,**  
 PRINCIPAL,  
 K S R INSTITUTE FOR  
 ENGINEERING AND TECHNOLOGY,  
 K.S.R. KALVI NAGAR,  
 TIRUCHENGODE-637 215,  
 NAMAKKAL Dt, TAMIL NADU.

S.NO	REG.NO	NAME OF THE STUDENT	Marks(50)
51	731614114088	MOHAN RAJ R	38
52	731614114089	MUGILESHWARAN K	36
53	731614114090	MUHILARASU S	37
54	731614114091	MUHINTHAR S	39
55	731614114095	NAINAR MOHAMED S	42
56	731614114096	NANDHA KUMAR P	38
57	731614114097	NARESHKUMAR B	36
58	731614114100	NAVEENKUMAR K P	45
59	731614114101	NETHAJI M	44
60	731614114102	NIVASAN K	41
61	731614114104	POOVARASAN S	36
62	731614114108	PRAKASH RAJ T	38
63	731614114109	PRANESH J	33
64	731614114110	PRASANTH C	31
65	731614114112	PREMKUMAR R	39
66	731614114113	RAAJKUMAR S	27
67	731614114114	RADHAKRISHNAN S	29
68	731614114117	RAJESH M	38
69	731614114119	RAJKUMAR S	41
70	731614114120	RAMAKRISHNAN P	37
71	731614114123	RANJITH KUMAR S	31
72	731614114124	SABAREESAN M	43
73	731614114128	SAM PRAKASH S	40
74	731614114132	SARAVANA MANOJ S	39
75	731614114133	SATHISH K	37
76	731614114135	SENTHUR R	35
77	731614114136	SHIVKUMAR S	46
78	731614114142	Srinivasan P	42
79	731614114143	Sukruth B	46
80	731614114146	Surya M	45
81	731614114150	Tamilselvan S	42
82	731614114152	Thirulogasanthar K	38
83	731614114159	Venugopal V	36
84	731614114163	Vijay S	37
85	731614114166	Vijayakumar M	39
86	731614114301	Boopathi P	42
87	731614114302	Chandru N	43
88	731614114311	Jeeva S	39
89	731614114312	Kaviyarsan S	37
90	731614114316	Mudaliyar Vishnu Parasuraman	38
91	731614114317	Naveen C	40
92	731614114319	Pradeepkumar R	43
93	731614114701	Shankar Ram R	39
<b>Course Coordinator</b>			
<b>HoD</b>			

  
**Dr. M. VENKATESAN, M.E., Ph.D.,**  
**PRINCIPAL,**  
**K S R INSTITUTE FOR**  
**ENGINEERING AND TECHNOLOGY,**  
**K.S.R. KALVI NAGAR,**  
**TIRUCHENGODE-637 215,**  
**NAMAKKAL Dt, TAMIL NADU**





**K S R INSTITUTE FOR ENGINEERING AND TECHNOLOGY**  
**Tiruchengode, Namakkal – 637215**

**Department of Mechanical Engineering**

Value Added Course - Creo for Automation and production

Date: 09/06/17

**FEEDBACK FORM**

Tick the Appropriate Columns:

Parameter	Excellent	Very Good	Good	Satisfactory
Content Delivered	/			
Registration	/			
Program Management		/		
Hospitality	/			
About Campus	/			

Participant Name: *N. Surya*

Suggestions for Improvement:

*N. Surya*  
Signature of the Participant

  
Dr. M. VENKATESAN, M.E., Ph.D.,  
PRINCIPAL,  
K S R INSTITUTE FOR  
ENGINEERING AND TECHNOLOGY,  
K.S.R. KALVI NAGAR,  
TIRUCHENGODE-637 215,  
NAMAKKAL DT, TAMIL NADU.



**K S R INSTITUTE FOR ENGINEERING AND TECHNOLOGY**  
Tiruchengode, Namakkal – 637215

**Department of Mechanical Engineering**

Value Added Course - Creo for Automation and production

Date: 09/06/17

**FEEDBACK FORM**

Tick the Appropriate Columns:

Parameter	Excellent	Very Good	Good	Satisfactory
Content Delivered	✓			
Registration		✓		
Program Management	✓			
Hospitality		✓		
About Campus	✓			

Participant Name: Jeeva S

Suggestions for Improvement:

Jeeva S  
Signature of the Participant

  
Dr. M. VENKATESAN, M.E., Ph.D.,  
PRINCIPAL,  
K S R INSTITUTE FOR  
ENGINEERING AND TECHNOLOGY,  
K.S.R. KALVI NAGAR,  
TIRUCHENGODE-637 215,  
NAMAKKAL Dt, TAMIL NADU.

# K S R INSTITUTE FOR ENGINEERING AND TECHNOLOGY

TIRUCHENGODE – 637 215

## DEPARTMENT OF MECHANICAL ENGINEERING

### VALUE ADDED / SHORT TERM COURSE – SUMMARY

Academic Year: 2017-18 (ODD)

<b>Name of the course</b>	Five days Value Added / Short Term course on CREO AUTOMATION AND PRODUCTION
<b>Course Contents</b>	➤ Enclosed
<b>Course Outcomes</b>	<ul style="list-style-type: none"><li>➤ Student will have seamless data sharing ability; they can easily design entire process, from concept design work to manufacturing the final product.</li><li>➤ Student can automatically do associative manufacturing and service deliverables generation.</li><li>➤ Student can add manufacturing businesses transition into model-based enterprises.</li><li>➤ Student will have enough skills to increase productivity, do better concept design, increase engineering &amp; manufacturing capabilities, do better simulation and additive manufacturing.</li></ul>
<b>Program Outcomes &amp; Program Specific Outcomes</b>	PO1,PO3,PO4,PO5,PO6,PO9,P10,PO12, PSO2
<b>Course Convener</b>	Dr.P.MURUGESAN, HoD/MECH
<b>Course Coordinators</b>	Mr.A.V.T SHUBHASH AP/MECH
<b>Resource Persons</b>	Mr.R.Nirmalraja, AP/MECH Mr.G.Gowrisankar, AP/MECH Mr.A.V.T Shubhash, AP/MECH
<b>Duration &amp; Dates</b>	Five days (38 Hours) & 05/06/17 to 09/06/17
<b>Participants &amp; Strength</b>	IV YEAR MECH KSRIET STUDENTS & 93

  
Coordinator

  
Dr. M. VENKATESAN, M.E., Ph.D.,  
PRINCIPAL,  
K S R INSTITUTE FOR  
ENGINEERING AND TECHNOLOGY,  
K.S.R. KALVI NAGAR,  
TIRUCHENGODE-637 215,  
NAMAKKAL DISTRICT, TAMIL NADU.

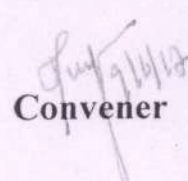
  
Convener



# K S R INSTITUTE FOR ENGINEERING & TECHNOLOGY

(APPROVED BY AICTE, NEW DELHI AND AFFILIATED TO ANNA UNIVERSITY, CHENNAI)



## DEPARTMENT OF MECHANICAL ENGINEERING CENTRE FOR VALUE ADDED EDUCATION (CENVAAE)

### VALUE ADDED COURSE CREO - AUTOMATION AND PRODUCTION

### CERTIFICATE OF PARTICIPATION

This is to certify that Mr. /Ms. M. SUBYA of IV-YEAR  
Department of Mechanical Engineering, K S R INSTITUTE FOR ENGINEERING AND  
TECHNOLOGY has attended a Five days value added course on "Creo  
Automation and production" organized by the Department of Mechanical  
Engineering, KSR IET from 05/06/17 to 09/06/17

  
**COORDINATOR**

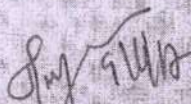
  
**HOD**

  
**Dr. M. VENKATESAN, M.E., Ph.D.,**  
**PRINCIPAL,**  
**K S R INSTITUTE FOR**  
**ENGINEERING AND TECHNOLOGY,**  
**K.S.R. KALVI NAGAR,**

  
**PRINCIPAL**

TRICHY CAMPUS  
NAMAKKAL DT. TAMIL NADU.

# KSR INSTITUTE FOR ENGINEERING AND TECHNOLOGY

&



**UNITED CADD SOLUTION** Private Limited

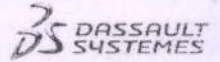

## SOLIDWORKS Syllabus

S.NO	TOPICS	No.of hours
1	Introduction	8
2	Sketcher	
3	Base Features	
4	Reference Features	
5	Engineering Features	12
6	Special Features	
7	Advanced Modeling	
8	Base Features	
9	Special Features	8
10	Advance features	
11	Applying standard mates	
12	Applying advanced mates	
13	Applying mechanical mates	12
14	Creating features	
15	Editing features	
16	Generating Drawing Views	
17	Inserting Annotations	

Total Period: 40

  
Dr. M. VENKATESAN, M.E., Ph.D.,  
PRINCIPAL,  
K S R INSTITUTE FOR  
ENGINEERING AND TECHNOLOGY,  
K.S.R. KALVI NAGAR,  
TIRUCHENGODE-637 215,  
NAMAKKAL Dt, TAMIL NADU.

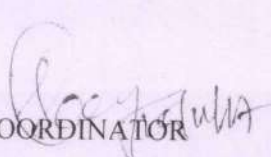
  
COORDINATOR



**K S R INSTITUTE FOR ENGINEERING AND TECHNOLOGY**  
**Tiruchengode, Namakkal – 637215**

**Department of Mechanical Engineering**

**Six Days Value Added Course – SOLID WORKS**  
**Schedule**

**Date: 04/12/2017**

S.No.	Date	Topic	Name of the Faculty
1.	11/12/17	Introduction About Solid Works, Various products available in SolidWorks for Product Design, Simulation, Communication Keyboard shortcuts, Command Manager, Hardware and Software requirements, SolidWorks Task Scheduler	Dr.P.Murugesan & Dr.R.Mani
2.	12/12/17	Sketch Entities – Inference line, Centerline line, Line, Circle, Arc, Ellipse, Rectangle, Slots, Polygon, Parabola, Ellipse, Partial Ellipse, Spline, Spline tools, Spline on surface, Equation driven curve, Points, Text, Construction geometry, Snap, grid	Mr.P.Gopinath & Mr.A.Mohanraj
3.	13/12/17	Sketch Tools - Construction Geometry, Mirror, Dynamic Mirror, Move, Copy, Rotate, Scale, Stretch, Sketch pattern , Polygon, Make path, Close Sketch To Model, Tools Creating reference planes Creating Extrude features – Direction1, Direction2, From option, Thin feature, Applying draft, Selecting contours	Dr.P.Murugesan & Dr.R.Mani
	14/12/17	Creating Revolve features – Selecting Axis, Thin features, Selecting contours Creating Swept features-Selecting, Profile and Path, Orientation/twist type, Path Alignment, Guide Curves, Start/End tangency, Thin feature, Assembly Modeling & Approaches – Top down and Bottom up approach, Applying Advanced – Cam, Hinge, Gear, Rack Pinion, Screw, Universal Joint.	Mr.P.Gopinath & Mr.A.Mohanraj
5.	15/12/17	Applying standard mates -Manipulating Components - Replacing Components, Rotating Components, Move Components, Collision Detection, Physical Dynamics, Dynamic Clearance, Detecting Interference, Surface Modeling tools Creating Extrude, Revolve, Swept, loft, and Boundary surface.	Dr.P.Murugesan & Dr.R.Mani
6.	16/12/17	Inserting Annotations Offset Surface, Radiate Surface. Sheet Metal Design Concepts in Sheet metal design bend allowance bend deduction, Inserting Base Flange, Sheet Metal Tab, Edge Flange, Miter Flange, Hem, Jog. Creating Break Corner/Corner Trim, Closed Corners, Rip.	Mr.P.Gopinath & Mr.A.Mohanraj

Faculty Incharge

**Dr. M. VENKATESAN, M.E., Ph.D.,**  
**PRINCIPAL,**  
**K S R INSTITUTE FOR**  
**ENGINEERING AND TECHNOLOGY,**  
**K.S.R. KALVI NAGAR**  
**TIRUCHENGODE-637 215,**  
**NAMAKKAL Dt. TAMIL NADU.**

HOD

**K S R Institute for Engineering and Technology**  
**Department of Mechanical Engineering**  
**Value Added Course on SOLIDWORKS**

Year:III

Attendance

Academic Year: 2017-18

S.NO	REG.NO	NAME OF THE STUDENT	11.12.17	12.12.17	13.12.17	14.12.17	15.12.17	16.12.17
1	731615114001	ADHISHANKARAN D	/	/	/	/	/	/
2	731615114002	AJITH K S	/	/	/	/	/	/
3	731615114007	ALEXANDER M	/	/	/	/	/	/
4	731615114009	ARAVINTHAN P V	/	/	/	/	/	/
5	731615114010	ARAVINTHASAMY B	/	/	/	/	/	/
6	731615114014	BALAJI M	/	/	/	/	/	/
7	731615114017	BALAKRISHNAN C	/	/	/	/	/	/
8	731615114020	BHARATH P	/	/	/	/	/	/
9	731615114021	BHARATHI K N	/	/	A	/	/	/
10	731615114025	CELLAKAMALALAKSHMI R	/	/	/	/	/	/
11	731615114027	DEENADHAYALAN P	/	/	/	/	/	/
12	731615114028	DEVA S	/	/	/	/	/	/
13	731615114035	DINESH K	/	/	/	/	/	/
14	731615114040	ELANGO V	A	/	/	A	/	/
15	731615114043	GIRI K	/	/	/	/	/	/
16	731615114044	GIRIDHARAN B	/	/	/	/	/	/
17	731615114048	GOKUL MAYURA PRIYAN B	/	/	/	/	/	/
18	731615114051	GOWTHAM K	/	/	/	/	/	/
19	731615114052	HARIPRASATH S	/	/	/	/	/	/
20	731615114055	JACKSON P V	/	/	A	/	/	A
21	731615114059	JAIKRISHNAN K	/	/	/	/	/	/
22	731615114098	NISHANTHI B	/	/	/	/	/	/
23	731615114301	AJITH M	/	/	/	/	/	/
24	731615114302	ARUN AAKASH S	/	/	/	/	/	/
25	731615114063	KARTHIKEYAN A	/	/	/	/	A	/
26	731615114065	KAVINKUMAR R	/	/	/	/	/	/
27	731615114069	KISHORE KUMAR M	/	A	/	/	/	/
28	731615114070	KUMAR P	/	/	/	/	/	/
29	731615114076	MANIKANDAN G	/	/	/	A	/	/
30	731615114082	MOHAMMED EHIYA S	/	/	/	/	/	/
31	731615114083	MOHANKUMAR R	/	/	/	/	/	/
32	731615114084	MOHANPRABHU K	/	/	/	/	/	/
33	731615114089	NARENDHIRAN M	/	/	/	/	/	/
34	731615114096	NAVEEN KUMAR N (8.6.98)	/	/	/	/	/	/
35	731615114097	NISHANTH E	/	/	/	/	/	/
36	731615114100	OM ADHAVAN B	/	/	/	/	/	/
37	731615114101	PALANISAMY R	/	A	/	/	/	/
38	731615114110	RAJAMANI M	/	/	/	/	/	/
39	731615114114	RANJITH R	/	/	/	/	/	/
40	731615114115	ROBERT SAM DANIEL	/	/	/	/	/	A
41	731615114306	ELAVARASAN D	/	/	/	/	/	/
42	731615114310	KARTHIKEYAN K	/	/	/	/	/	/
43	731615114702	KATHIRAVAN S	/	/	/	/	/	/
44	731615114116	SABARIRAJ D	/	/	/	/	/	/
45	731615114120	SANTHOSH K	/	/	/	/	/	/
46	731615114123	SANTHOSH KUMAR R	/	/	/	/	/	/

  
**Dr. M. VENKATESAN, M.E., Ph.D.,**  
**PRINCIPAL,**  
**K S R INSTITUTE FOR**  
**ENGINEERING AND TECHNOLOGY,**  
**K.S.R. KALVI NAGAR,**  
**TIRUCHENGODE-637 215,**  
**NAMAKKAL Dt, TAMIL NADU**

S.NO	REG.NO	NAME OF THE STUDENT	11.12.17	12.12.17	13.12.17	14.12.17	15.12.17	16.12.17
47	731615114124	SARAVANAN M	/	/	/	/	/	/
48	731615114125	SASIKUMAR S (28.12.1996)	/	/	/	/	/	/
49	731615114130	SATHISH KUMAR G	/	/	/	/	/	/
50	731615114131	SELVAKUMAR R	/	/	A	/	/	/
51	731615114134	SHEIKMOHAMED M	/	/	/	/	/	/
52	731615114135	SHREERAM M R	/	/	/	/	A	/
53	731615114136	SHUKEL AHAMED M	/	/	/	/	/	/
54	731615114137	SHYAM SUNDAR S	/	/	/	/	/	/
55	731615114140	SUBHASH S	/	/	/	/	/	/
56	731615114141	SUDHAKAR R M	/	/	/	/	/	/
57	731615114142	SUDHARSEN M	/	/	/	/	/	/
58	731615114144	SUGANESHWARAN G	A	/	/	/	/	/
59	731615114146	SURYA S C	/	/	/	/	/	/
60	731615114147	SYLESH P	/	/	/	/	/	/
61	731615114151	THAMIL SELVAM S	/	/	/	A	/	/
62	731615114152	UMANATH G	/	/	/	/	/	/
63	731615114156	VENKADESAN I	/	/	/	/	/	/
64	731615114157	VENUGOPAL P	/	A	/	/	/	/
65	731615114158	VIGNESH M	/	/	/	/	A	/
66	731615114161	VIJAY M	/	/	/	/	/	A
67	731615114162	VIJAY P	/	/	/	/	/	/
68	731615114163	VIMALRAJ R	/	/	/	/	/	/
69	731615114164	VINOTH KUMAR P	/	/	/	A	/	/
70	731615114165	VISHNUKUMAR R	/	/	/	/	/	/
71	731615114314	NETHAJI M	A	/	/	/	/	/
72	731615114315	PRAVEEN M R	/	/	/	/	/	/
73	731615114316	PRAVINTH .K	/	/	/	/	A	/
74	731615114317	RADHAKRISHNAN M	/	/	/	/	/	/
75	731615114318	RANJITHKUMAR .M	/	/	A	/	/	/
76	731615114323	THIRU MOORTHY B	/	/	/	/	/	/
Course Coordinator			/	/	/	/	/	/
HoD			/	/	/	/	/	/

  
**Dr. M. VENKATESAN, M.E., Ph.D.,**  
**PRINCIPAL,**  
**K S R INSTITUTE FOR**  
**ENGINEERING AND TECHNOLOGY,**  
**K.S.R. KALVI NAGAR,**  
**TIRUCHENGODE-637 215,**  
**NAMAKKAL Dt. TAMIL NADU.**



KSR INSTITUTE FOR ENGINEERING AND TECHNOLOGY  
DEPARTMENT OF MECHANICAL ENGINEERING

Centre for Value Added Education (CENVAE)  
Assessment Test for Solid Works course  
Attend any one question

Date: '16.12.17  
MARK (50)

1)

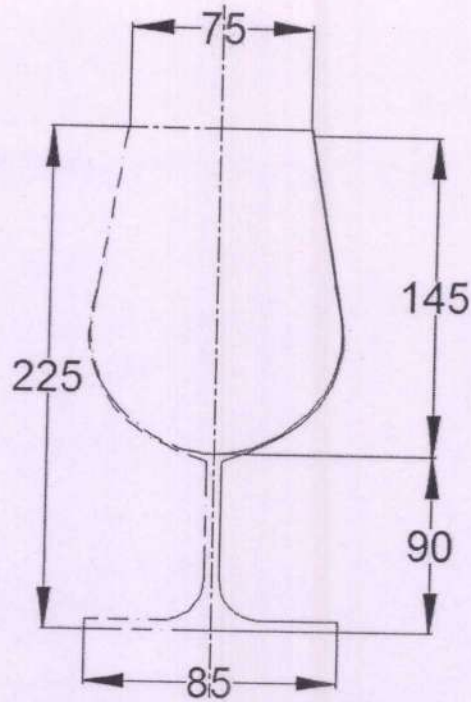

2)

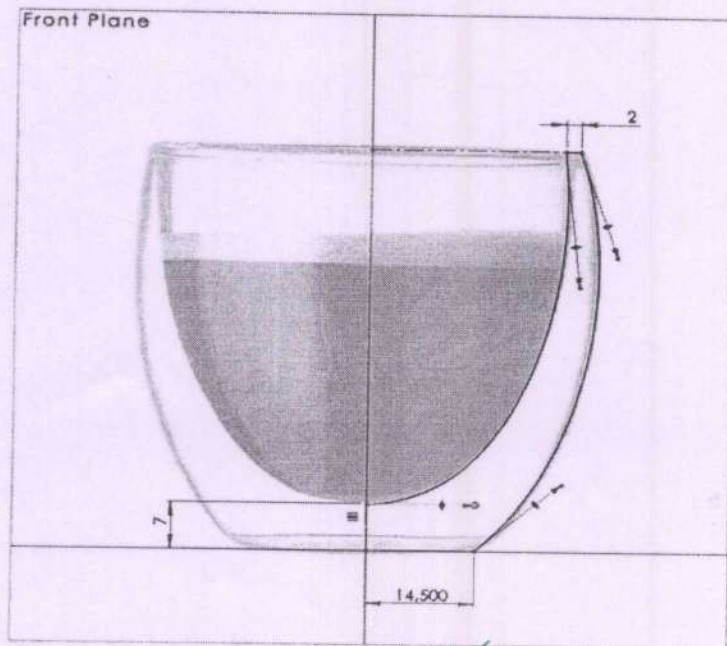

Coordinator

Dr. M. VENKATESAN, M.E., Ph.D.,  
PRINCIPAL,  
K S R INSTITUTE FOR  
ENGINEERING AND TECHNOLOGY,  
K.S.R. KALVI NAGAR,  
TIRUCHENGODE-637 215,  
NAMAKKAL Dt, TAMIL NADU.

HoD

**K S R Institute for Engineering and Technology**  
**Department of Mechanical Engineering**  
**Value Added Course on SOLIDWORKS**

**Year:III**

**Assessment Mark**

**Academic Year:2017-18**

S.NO	REG.NO	NAME OF THE STUDENT	MARKS (50)
1	731615114001	ADHISHANKARAN D	41
2	731615114002	AJITH K S	37
3	731615114007	ALEXANDER M	31
4	731615114009	ARAVINTHAN P V	43
5	731615114010	ARAVINTHASAMY B	39
6	731615114014	BALAJI M	38
7	731615114017	BALAKRISHNAN C	36
8	731615114020	BHARATH P	34
9	731615114021	BHARATHI K N	45
10	731615114025	CELLAKAMALALAKSHMI R	41
11	731615114027	DEENADHAYALAN P	45
12	731615114028	DEVA S	44
13	731615114035	DINESH K	41
14	731615114040	ELANGO V	37
15	731615114043	GIRI K	38
16	731615114044	GIRIDHARAN B	36
17	731615114048	GOKUL MAYURA PRIYAN B	45
18	731615114051	GOWTHAM K	44
19	731615114052	HARIPRASATH S	44
20	731615114055	JACKSON P V	36
21	731615114059	JAIKRISHNAN K	37
22	731615114098	NISHANTHI B	39
23	731615114301	AJITH M	42
24	731615114302	ARUN AAKASH S	38
25	731615114063	KARTHIKEYAN A	36
26	731615114065	KAVINKUMAR R	45
27	731615114069	KISHORE KUMAR M	44
28	731615114070	KUMAR P	40
29	731615114076	MANIKANDAN G	44
30	731615114082	MOHAMMED EHIYA S	43
31	731615114083	MOHANKUMAR R	40
32	731615114084	MOHANPRABHU K	36
33	731615114089	NARENDHIRAN M	37
34	731615114096	NAVEEN KUMAR N (8.6.98)	35
35	731615114097	NISHANTH E	44
36	731615114100	OM ADHAVAN B	43
37	731615114101	PALANISAMY R	43
38	731615114110	RAJAMANI M	35
39	731615114114	RANJITH R	36
40	731615114115	ROBERT SAM DANIEL	38
41	731615114306	ELAVARASAN D	41
42	731615114310	KARTHIKEYAN K	37
43	731615114702	KATHIRAVAN S	35
44	731615114116	SABARIRAJ D	44
45	731615114120	SANTHOSH K	43
46	731615114123	SANTHOSH KUMAR R	38
47	731615114124	SARAVANAN M	36
48	731615114125	SASIKUMAR S (28.12.1996)	45
49	731615114130	SATHISH KUMAR G	44

Dr. M. VENKATESAN, M.E., Ph.D.,  
 PRINCIPAL,

K S R INSTITUTE FOR  
 ENGINEERING AND TECHNOLOGY,  
 K.S.R. KALVI NAGAR,  
 TIRUCHENGODE-637 215,  
 NAMAKKAL DISTRICT, TAMIL NADU

S.NO	REG.NO	NAME OF THE STUDENT	MARKS (50)
50	731615114131	SELVAKUMAR R	40
51	731615114134	SHEIKMOHAMED M	44
52	731615114135	SHREERAM M R	43
53	731615114136	SHUKEL AHAMED M	40
54	731615114137	SHYAM SUNDAR S	36
55	731615114140	SUBHASH S	37
56	731615114141	SUDHAKAR R M	35
57	731615114142	SUDHARSEN M	45
58	731615114144	SUGANESHWARAN G	41
59	731615114146	SURYA S C	43
60	731615114147	SYLESH P	45
61	731615114151	THAMIL SELVAM S	38
62	731615114152	UMANATH G	36
63	731615114156	VENKADESAN I	34
64	731615114157	VENUGOPAL P	45
65	731615114158	VIGNESH M	41
66	731615114161	VIJAY M	45
67	731615114162	VIJAY P	44
68	731615114163	VIMALRAJ R	41
69	731615114164	VINOTH KUMAR P	37
70	731615114165	VISHNUKUMAR R	38
71	731615114314	NETHAJI M	36
72	731615114315	PRAVEEN M R	45
73	731615114316	PRAVINTH .K	44
74	731615114317	RADHAKRISHNAN M	44
75	731615114318	RANJITHKUMAR .M	36
76	731615114323	THIRU MOORTHY B	37
Course Coordinator			
HoD			

  
**Dr. M. VENKATESAN, M.E., Ph.D.**  
 PRINCIPAL,  
 K S R INSTITUTE FOR  
 ENGINEERING AND TECHNOLOGY,  
 K.S.R. KALVI NAGAR,  
 TIRUCHENGODE-637 215,  
 NAMAKKAL DT, TAMIL NADU.



**K S R INSTITUTE FOR ENGINEERING AND TECHNOLOGY**  
Tiruchengode, Namakkal – 637215

**Department of Mechanical Engineering**

Value Added Course - SOLIDWORKS

Date: 16/12/2017

**FEEDBACK FORM**

Tick the Appropriate Columns:

Parameter	Excellent	Very Good	Good	Satisfactory
Content Delivered	<input checked="" type="checkbox"/>	<input type="checkbox"/>	<input type="checkbox"/>	<input type="checkbox"/>
Registration	<input type="checkbox"/>	<input checked="" type="checkbox"/>	<input type="checkbox"/>	<input type="checkbox"/>
Program Management	<input type="checkbox"/>	<input checked="" type="checkbox"/>	<input type="checkbox"/>	<input type="checkbox"/>
Hospitality	<input type="checkbox"/>	<input checked="" type="checkbox"/>	<input type="checkbox"/>	<input type="checkbox"/>
About Campus	<input checked="" type="checkbox"/>	<input type="checkbox"/>	<input type="checkbox"/>	<input type="checkbox"/>

Participant Name: *B. Ranjith*

Suggestions for Improvement:

*B. Ranjith*  
Signature of the Participant

  
Dr. M. VENKATESAN, M.E., Ph.D.,  
PRINCIPAL,  
K S R INSTITUTE FOR  
ENGINEERING AND TECHNOLOGY,  
K.S.R. KALVI NAGAR,  
TIRUCHENGODE-637 215,  
NAMAKKAL Dt, TAMIL NADU.



**K S R INSTITUTE FOR ENGINEERING AND TECHNOLOGY**  
Tiruchengode, Namakkal – 637215

**Department of Mechanical Engineering**

Value Added Course - SOLIDWORKS

Date: 16/12/2017

**FEEDBACK FORM**

Tick the Appropriate Columns:

Parameter	Excellent	Very Good	Good	Satisfactory
Content Delivered	/			
Registration		/		
Program Management	/			
Hospitality		/		
About Campus	/			

Participant Name: VIJAY P

Suggestions for Improvement:

  
Dr. M. VENKATESAN, M.E., Ph.D.  
PRINCIPAL,  
K S R INSTITUTE FOR  
ENGINEERING AND TECHNOLOGY,  
K.S.R. KALVI NAGAR,  
TIRUCHENGODE-637 215,  
NAMAKKAL Dt, TAMIL NADU.

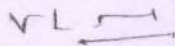
  
Signature of the Participant

# K S R INSTITUTE FOR ENGINEERING AND TECHNOLOGY

TIRUCHENGODE – 637 215

## DEPARTMENT OF MECHANICAL ENGINEERING

### VALUE ADDED / SHORT TERM COURSE – SUMMARY

Academic Year: 2017-18 (ODD)

<b>Name of the course</b>	Six days Value Added / Short Term course on Solid Works
<b>Course Contents</b>	➤ <b>Enclosed</b>
<b>Course Outcomes</b>	<ul style="list-style-type: none"><li>➤ Demonstrate competency with multiple drawing and modification commands in SOLIDWORKS.</li><li>➤ Create three-dimensional solid models.</li><li>➤ Create three-dimensional assemblies incorporating multiple solid models.</li><li>➤ Apply industry standards in the preparation of technical mechanical drawings.</li><li>➤ Create Simulation of the assemblies incorporating multiple solid models</li></ul>
<b>Program Outcomes &amp; Program Specific Outcomes</b>	PO1,PO3,PO4,PO5,PO6,PO9,P10,PO12, PSO2
<b>Course Convener</b>	Dr.P.Murugesan,HoD/MECH
<b>Course Coordinators</b>	Mr.A.V.T SHUBHASH AP/MECH
<b>Resource Persons</b>	Dr.P.Murugesan AP/MECH Dr.R.Mani AP/MECH Mr P.Gopinath AP/MECH Mr A.Mohanraj AP/MECH
<b>Duration &amp; Dates</b>	Six days (40 Hours) & 11/12/17 to 16/12/17
<b>Participants &amp; Strength</b>	III YEAR MECH KSRIET STUDENTS & 76

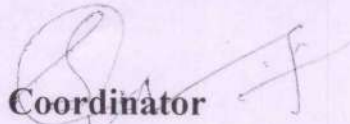
  
Coordinator

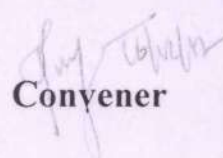
  
Convener

  
Dr., M. VENKATESAN, M.E., Ph.D.,  
PRINCIPAL.  
K S R INSTITUTE FOR  
ENGINEERING AND TECHNOLOGY,  
K.S.R. KALVI NAGAR,  
TIRUCHENGODE-637 215,  
NAMAKKAL Dt, TAMIL NADU.

**KSR INSTITUTE FOR ENGINEERING AND TECHNOLOGY  
DEPARTMENT OF MECHANICAL ENGINEERING  
CENTRE FOR VALUE ADDED EDUCATION (CENVAE)**



**VALUE ADDED COUSE FOR SOLID WORKS**



**VALUE ADDED COUSE FOR SOLID WORKS**

  
**Dr., M. VENKATESAN, M.E., Ph.D.,  
PRINCIPAL,  
K S R INSTITUTE FOR  
ENGINEERING AND TECHNOLOGY,  
K.S.R. KALVI NAGAR,  
TIRUCHENGODE-637 215,  
NAMAKKAL Dt, TAMIL NADU.**



www.unitedcaddsolution.com

DESIGN THE FUTURE

**UNITED CADD SOLUTION**

Private Limited

Corporate Office : #516/228-D, Annapuram,  
Junction Main Road,  
Five Roads, Salem, Tamilnadu -636 004.



**KSR Institute For Engineering  
& Technology, Tiruchengode.**



# CERTIFICATE OF EXCELLENCE

Reg. No. : UCS - KSR0110

Awarded to : RAJAMANI M

in : SOLID WORKS

at : KSRIET

Duration : 40 Hrs

Grade\* : H\*

Date of Issue : DECEMBER - 2018

\*C : 40-50, D : 50-60, A : 60-75, H : Above 75

  
Course Co-Ordinator

  
HOD

  
Principal

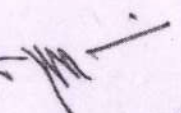
  
Director

Dr. M. VENKATESAN, M.E., Ph.D.  
PRINCIPAL,  
K S R INSTITUTE FOR  
ENGINEERING AND TECHNOLOGY,  
K.S.R. KALVI NAGAR,  
TIRUCHENGODE-637 215,  
NAMANKAL Dt, TAMIL NADU.







**UNITED CADD SOLUTION** Private Limited &

**KSR INSTITUTE FOR ENGINEERING AND  
TECHNOLOGY**

**PIPING SCHEDULE**

S. No	Topic	Hours
1	Introduction <ul style="list-style-type: none"><li>• Piping software</li><li>• PDS / PDMS / P&amp;ID</li><li>• Introduction to CAESAR II</li><li>• Scope &amp; Responsibilities of Piping Engineer</li></ul> Features of CAESAR II <ul style="list-style-type: none"><li>• CAESAR II interface</li><li>• Fundamentals of Pipe Design</li><li>• Piping standards</li></ul>	6
2	Basics parameters <ul style="list-style-type: none"><li>• Caesar II Configuration</li><li>• Node no. &amp; names</li><li>• Pipe dia. &amp; standard schedule pipe wall (Wt/Sch)</li><li>• Temperature &amp; pressure</li></ul> Basic operation <ul style="list-style-type: none"><li>• Routing</li><li>• Joints &amp; Fittings</li><li>• Equipment</li></ul>	6
3	Plant modelling <ul style="list-style-type: none"><li>• Input data</li><li>• Create design</li><li>• Edit model</li><li>• Navigation tools</li></ul> Visualization <ul style="list-style-type: none"><li>• Standard tools</li><li>• Display options</li><li>• Cutting plane</li></ul>	6
4	Purpose of stress analysis <ul style="list-style-type: none"><li>• Theory of failure</li><li>• Load cases</li><li>• Material selection</li><li>• Code Compliance for ASME B31.3</li></ul>	8
5	Isometric Drawing Extraction	8

COORDINATOR

**Dr. M. VENKATESAN, M.E., Ph.D.,**  
PRINCIPAL.  
K S R INSTITUTE FOR  
ENGINEERING AND TECHNOLOGY,  
K.S.R. KALVI NAGAR,  
TIRUCHENGODE - 637 215,  
NAMAKKAL Dt, TAMIL NADU.

Total Period: 34



**K S R INSTITUTE FOR ENGINEERING AND TECHNOLOGY**  
Tiruchengode, Namakkal – 637215

**Department of Mechanical Engineering**

## Five Days Value Added Course – CCP-PIPING

### Schedule

Date: 01/12/17

S.No.	Date	Topic	Name of the Faculty
1.	04/12/17	Introduction Piping software PDS / PDMS /P&ID, Introduction to CAESARII, Scope & Responsibilities of Piping Engineer Features of CAESAR II CAESAR I Iinterface, Fundamentals of Pipe Design Piping standards	Mr.M.Kannan (United CAD ) Mr.S.Rahul
2.	05/12/17	Basics parameters Caesar II Configuration, Node no. & names, Pipe dia. & standard schedule pipe wall(Wt/Sch), Temperature & pressure ,Basic operation, Routing, Joints & Fittings, Equipment	Mr.M.Kannan (United CAD ) & Mr.V.K.Vasanth
3.	06/12/17	Plant modelling Input data , Create design, Edit model, Navigation tools Visualization , Standard tools, Display options, Cutting plane	Mr.M.Kannan (United CAD ) & Mr.S.Rahul
4.	07/12/17	Purpose of stress analysis Theory of failure , Load cases, Material selection, Code Compliance for ASME B31.3	Mr.M.Kannan (United CAD ) & Mr.K.Kavin raj
5.	08/12/17	Isometric Drawing Extraction	Mr.M.Kannan (United CAD ) & Mr.K.Kavin raj

  
COORDINATOR

  
Dr. M. VENKATESAN, M.E., Ph.D.,  
PRINCIPAL,  
K S R INSTITUTE FOR  
ENGINEERING AND TECHNOLOGY,  
K.S.R. KALVI NAGAR,  
TIRUCHENGODE-637 215,  
NAMAKKAL DI, TAMIL NADU.

  
HOD

**K S R Institute for Engineering and Technology**  
**Department of Mechanical Engineering**  
**Value added course for CCP - PIPING**

Year:IV

Attendance

Academic Year:2017-18

S.NO	REG.NO	NAME OF THE STUDENT	04.12.17	05.12.17	06.12.17	07.12.17	08.12.17
1	731614114003	AJITHKUMAR M	/	/	/	/	/
2	731614114007	ANAND S	/	/	/	A	/
3	731614114008	ANEESH S	/	/	/	/	/
4	731614114013	ARAVITNH K	/	/	/	/	/
5	731614114017	ARJUN T	/	/	/	/	/
6	731614114018	ARUL PRAKASH P	/	/	/	/	/
7	731614114021	AYYANDHURAI P	/	/	/	/	/
8	731614114027	DEEPAN CHAKRAVARTHI . S	/	A	/	/	/
9	731614114031	DHANUSH KUMAR K	/	/	/	/	/
10	731614114032	DHAYANITHI R	/	/	/	/	/
11	731614114034	DINESHKUMAR M	/	/	/	A	/
12	731614114036	EYAD MUHAMMED	/	/	/	/	/
13	731614114040	GOKUL RAJ. M	/	/	/	/	/
14	731614114041	GOWTHAM.P	/	/	A	/	/
15	731614114043	GOWTHAMAN S	/	/	/	/	/
16	731614114046	HARIHARAN K	/	/	/	/	/
17	731614114047	HARIHARAN M	/	/	/	/	/
18	731614114052	IZAZA AHAMMED	/	A	/	/	/
19	731614114055	KAMALAKANNAN V	/	/	/	/	/
20	731614114058	KARTHICK RAJ P	/	/	/	/	/
21	731614114059	KARTHI S	/	/	/	/	/
22	731614114061	KARTHIKEYAN S	/	/	/	/	/
23	731614114062	KARTHIKEYAN S	/	/	A	/	/
24	731614114069	LAVANYA S	/	/	/	/	/
25	731614114070	LAXMANAN M	/	/	/	/	/
26	731614114082	MOHAMED KASIF F	/	/	/	/	/
27	731614114085	MOHAMED YUNUS A	/	/	/	/	/
28	731614114086	MOHAN P	/	/	/	/	/
29	731614114092	MUNIRAJ R	/	/	/	/	/
30	731614114093	MUTHUKUMAR C	/	/	A	/	/
31	731614114099	NAVEEN T P	/	/	/	/	/
32	731614114103	PADMANABAN J	/	/	/	/	/
33	731614114105	PRABHAKARAN S	/	A	/	/	/
34	731614114106	PRADEEP N	/	/	/	/	/
35	731614114111	PRAVEENSON W	/	/	/	/	/
36	731614114115	RAGHUL KUMAR K	/	/	/	/	/
37	731614114116	RAJASEKAR A	/	/	/	A	/
38	731614114121	RANJITH KUMAR C	/	/	/	/	/
39	731614114122	RANJITH KUMAR M	/	/	A	/	/
40	731614114125	SABARI G	/	/	/	/	/
41	731614114129	SANGAMESHWARAN M	/	/	/	/	/
42	731614114131	SANKAR V	/	/	/	/	/
43	731614114134	SATHISHRAJ K	/	/	/	/	/
44	731614114137	SIPRESH M R	/	/	/	/	/
45	731614114138	SIVA M	/	A	/	/	/
46	731614114139	SRIDHAR K	/	/	/	/	/
47	731614114140	SRIDHAR R	/	/	/	/	/
48	731614114141	SRINATH V	/	/	/	A	/
49	731614114144	Suresh P	/	/	/	/	/
50	731614114147	Suryaprakash K	/	/	/	/	/

  
**DR. M. VENKATESH, M.E. Ph.D.**  
 PRINCIPAL  
 K. S. R. INSTITUTE FOR  
 ENGINEERING AND TECHNOLOGY,  
 K.S.R. KALVI NAGAR,  
 TIRUCHENGODE-637 215,  
 NAMAKKAL DI, TAMIL NADU.

S.NO	REG.NO	NAME OF THE STUDENT	04.12.17	05.12.17	06.12.17	07.12.17	08.12.17
51	731614114149	Tamilmani P	/	/	/	/	/
52	731614114151	Tarun Chouhan S	/	/	/	/	/
53	731614114153	Vaitheswaran A	/	/	/	/	/
54	731614114156	Venkadesh S	/	A	/	/	A
55	731614114157	Venkatesh P	/	/	/	/	/
56	731614114160	Vignesh D	/	/	/	/	/
57	731614114161	Vigneshwaran B	/	/	/	A	/
58	731614114162	Vigneshwaran K	/	/	/	/	/
59	731614114164	Vinithkumar A	/	A	/	/	/
60	731614114165	Vishwanathan M S	/	/	/	/	/
61	731614114303	Dineshkumar R	/	/	/	/	A
62	731614114304	Dineshragupathy S	/	/	A	/	/
63	731614114305	Duraimurugan R	/	/	/	/	/
64	731614114306	Elavarasan M	/	/	/	/	/
65	731614114307	Gokulkannan N	/	/	/	/	/
66	731614114308	Gopalakrishnan S	/	A	/	/	/
67	731614114309	Gopinath K	/	/	/	/	/
68	731614114310	Gowtham M	/	/	/	A	/
69	731614114313	Logesh A	/	/	/	/	/
70	731614114314	Madhan Raj D	/	/	/	/	A
71	731614114317	Naveen C	/	/	/	/	/
72	731614114322	Ramkumar R	/	A	A	/	/
73	731614114327	Suriyanarayanan R	/	/	/	/	/
74	731614114329	Venkatesh P	/	/	/	A	/
75	731614114330	Vignesh L	/	/	/	/	/
76	731614114331	Vivekkumar G	/	/	/	/	/
77	731614114332	Yogeshkumaran R I	/	/	A	/	A
78	731614114702	Velsaran M	/	/	/	/	/
79	731614114703	Tamizharasan A	A	/	/	/	/
80	731614114704	Arun S V	/	/	/	/	/
Course Coordinator			/	/	/	/	/
HoD			/	/	/	/	/

  
**Dr. M. VENKATESAN, M.E., Ph.D.,**  
 PRINCIPAL  
**K S R INSTITUTE FOR**  
**ENGINEERING AND TECHNOLOGY,**  
**K.S.R. KALVI NAGAR,**  
**TIRUCHENGODE-637 215,**  
**NAMAKKAL Dt, TAMIL NADU.**

**KSR INSTITUTE FOR ENGINEERING AND TECHNOLOGY**  
**DEPARTMENT OF MECHANICAL ENGINEERING**

Centre for Value Added Education (CENVAE)

Assessment Test for Piping course

Attend any one question

Date: 8-12-17

MARK (50)

1. Draw the Assemble of pipe line.

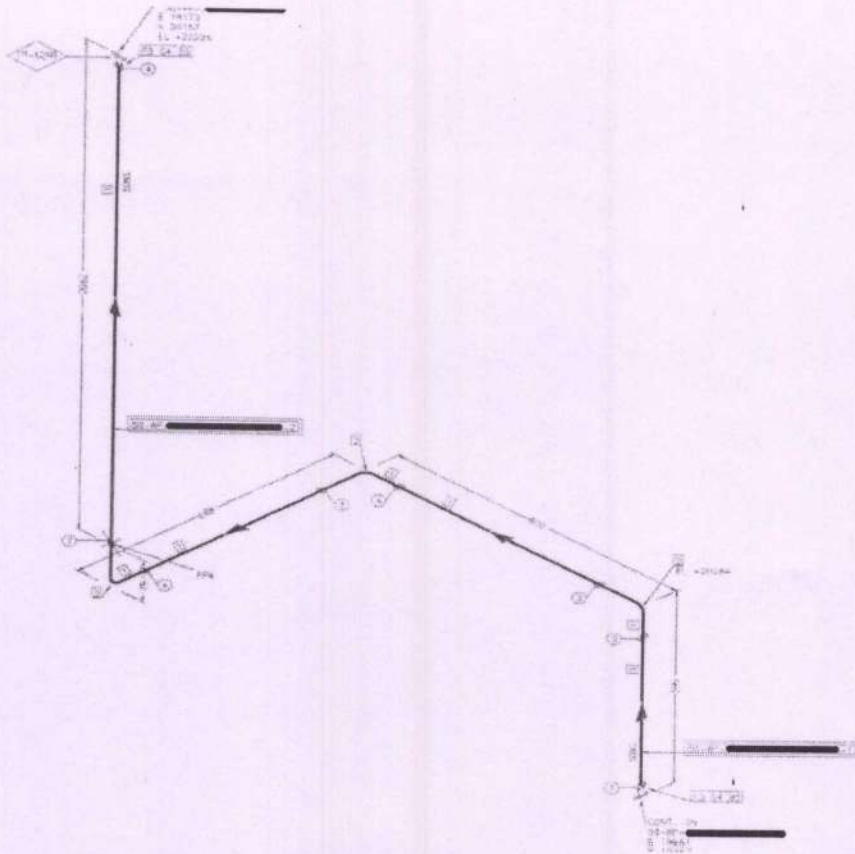

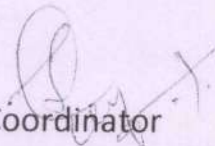
  
Coordinator

  
**Dr. M. VENKAYESAN, M.E., Ph.D.,**  
PRINCIPAL,  
K S R INSTITUTE FOR  
ENGINEERING AND TECHNOLOGY,  
K.S.R. KALVI NAGAR,  
TIRUCHENGODE-637 215,  
NAMAKKAL Dt, TAMIL NADU.

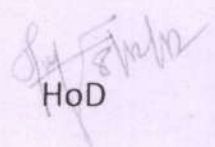
  
HoD

**K S R Institute for Engineering and Technology**  
**Department of Mechanical Engineering**  
**Value Added Course on CCP - PIPING**

Year: **II**      Assessment Mark      Academic Year: **2017-18**

S.NO	REG.NO	NAME OF THE STUDENT	Marks(50)
1	731614114003	AJITHKUMAR M	45
2	731614114007	ANAND S	41
3	731614114008	ANEESH S	42
4	731614114013	ARAVITNH K	48
5	731614114017	ARJUN T	39
6	731614114018	ARUL PRAKASH P	40
7	731614114021	AYYANDHURAI P	42
8	731614114027	DEEPAN CHAKRAVARTHI . S	40
9	731614114031	DHANUSH KUMAR K	42
10	731614114032	DHAYANITHI R	46
11	731614114034	DINESHKUMAR M	42
12	731614114036	EYAD MUHAMMED	41
13	731614114040	GOKUL RAJ. M	45
14	731614114041	GOWTHAM.P	46
15	731614114043	GOWTHAMAN S	42
16	731614114046	HARIHARAN K	41
17	731614114047	HARIHARAN M	40
18	731614114052	IZAZA AHAMMED	45
19	731614114055	KAMALAKANNAN V	47
20	731614114058	KARTHICK RAJ P	48
21	731614114059	KARTHI S	42
22	731614114061	KARTHIKEYAN S	45
23	731614114062	KARTHIKEYAN S	41
24	731614114069	LAVANYA S	44
25	731614114070	LAXMANAN M	40
26	731614114082	MOHAMED KASIF F	41
27	731614114085	MOHAMED YUNUS A	47
28	731614114086	MOHAN P	38
29	731614114092	MUNIRAJ R	39
30	731614114093	MUTHUKUMAR C	41
31	731614114099	NAVEEN T P	39
32	731614114103	PADMANABAN J	41
33	731614114105	PRABHAKARAN S	45
34	731614114106	PRADEEP N	41
35	731614114111	PRAVEENSON W	40
36	731614114115	RAGHUL KUMAR K	44
37	731614114116	RAJASEKAR A	45
38	731614114121	RANJITH KUMAR C	41
39	731614114122	RANJITH KUMAR M	40
40	731614114125	SABARI G	39
41	731614114129	SANGAMESHWARAN M	44
42	731614114131	SANKAR V	46
43	731614114134	SATHISHRAJ K	47
44	731614114137	SIPRESH M R	41
45	731614114138	SIVA M	44
46	731614114139	SRIDHAR K	40
47	731614114140	SRIDHAR R	45
48	731614114141	SRINATH V	45

M. VENKATESAN, M.E., Ph.D.,  
 PRINCIPAL,

K S R INSTITUTE FOR  
 ENGINEERING AND TECHNOLOGY,  
 K.S.R. KALVI NAGAR,  
 TIRUCHENGODE-637 215,  
 NAMAKKAL Dt, TAMIL NADU

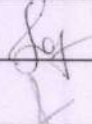
S.NO	REG.NO	NAME OF THE STUDENT	Marks(50)
49	731614114144	Suresh P	41
50	731614114147	Suryaprakash K	42
51	731614114149	Tamilmani P	48
52	731614114151	Tarun Chouhan S	39
53	731614114153	Vaitheswaran A	40
54	731614114156	Venkadesh S	42
55	731614114157	Venkatesh P	40
56	731614114160	Vignesh D	42
57	731614114161	Vigneshwaran B	46
58	731614114162	Vigneshwaran K	46
59	731614114164	Vinithkumar A	45
60	731614114165	Vishwanathan M S	44
61	731614114303	Dineshkumar R	42
62	731614114304	Dineshragupathy S	45
63	731614114305	Duraimurugan R	41
64	731614114306	Elavarasan M	40
65	731614114307	Gokulkannan N	42
66	731614114308	Gopalakrishnan S	45
67	731614114309	Gopinath K	48
68	731614114310	Gowtham M	42
69	731614114313	Logesh A	46
70	731614114314	Madhan Raj D	41
71	731614114317	Naveen C	40
72	731614114322	Ramkumar R	45
73	731614114327	Suriyanarayanan R	42
74	731614114329	Venkatesh P	41
75	731614114330	Vignesh L	45
76	731614114331	Vivekkumar G	48
77	731614114332	Yogeshkumaran R I	46
78	731614114702	Velsaran M	42
79	731614114703	Tamizharasan A	45
80	731614114704	Arun S V	41
<b>Course Coordinator</b>			
<b>HoD</b>			

  
**Dr. M. VENKATESAN, M.E., Ph.D.,**  
**PRINCIPAL,**  
**K S R INSTITUTE FOR**  
**ENGINEERING AND TECHNOLOGY,**  
**K.S.R. KALVI NAGAR,**  
**TIRUCHENGODE-637 215,**  
**NAMAKKAL Dt, TAMIL NADU.**



**K S R INSTITUTE FOR ENGINEERING AND TECHNOLOGY**

**Tiruchengode, Namakkal – 637215**

**Department of Mechanical Engineering**

**Value Added Course - PIPING**

**Date: 08/12/2017**

**FEEDBACK FORM**

**Tick the Appropriate Columns:**

Parameter	Excellent	Very Good	Good	Satisfactory
Content Delivered	/			
Registration		/		
Program Management	/			
Hospitality	/	X		
About Campus	/			

**Participant Name:** *J. Arand*

**Suggestions for Improvement:**

**Dr. M. VENKATESAN, M.E., Ph.D.,  
PRINCIPAL,  
K S R INSTITUTE FOR  
ENGINEERING AND TECHNOLOGY,  
K.S.R. KALVI NAGAR,  
TIRUCHENGODE-637 215,  
NAMAKKAL Dt, TAMIL NADU.**

*J. Arand*  
**Signature of the Participant**





**K S R INSTITUTE FOR ENGINEERING AND TECHNOLOGY**  
Tiruchengode, Namakkal – 637215

**Department of Mechanical Engineering**

**Value Added Course - PIPING**

**Date: 08/12/2017**

**FEEDBACK FORM**

**Tick the Appropriate Columns:**

Parameter	Excellent	Very Good	Good	Satisfactory
Content Delivered	✓			
Registration		✓		
Program Management	✓			
Hospitality		✓		
About Campus	✓			

**Participant Name:** Gowdhan P

**Suggestions for Improvement:**

Gowdhan P

**Signature of the Participant**

  
**Dr. M. VENKATESAN, M.E., Ph.D.,**  
PRINCIPAL.  
K S R INSTITUTE FOR  
ENGINEERING AND TECHNOLOGY,  
K.S.R. KALVI NAGAR,  
TIRUCHENGODE-637 215,  
NAMAKKAL Dt, TAMIL NADU.

# K S R INSTITUTE FOR ENGINEERING AND TECHNOLOGY

TIRUCHENGODE – 637 215

## DEPARTMENT OF MECHANICAL ENGINEERING

### VALUE ADDED / SHORT TERM COURSE – SUMMARY

Academic Year: 2017-18 (ODD)

<b>Name of the course</b>	Five days Value Added / Short Term course on Piping
<b>Course Contents</b>	➤ <b>Enclosed</b>
<b>Course Outcomes</b>	<ul style="list-style-type: none"><li>➤ To know the Scope &amp; Responsibilities of Piping Engineer</li><li>➤ To know the Basics parameters and basic operations, Routing, Joints &amp; Fittings, Equipment</li><li>➤ To increase the creativity of plant modeling</li><li>➤ To develop the knowledge of stress analysis</li></ul>
<b>Program Outcomes &amp; Program Specific Outcomes</b>	PO1,PO3,PO4,PO5,PO6,PO9,P10,PO12, PSO2
<b>Course Convener</b>	Dr.P.Murugesan, HoD/MECH
<b>Course Coordinators</b>	Mr.A.V.T SHUBHASH AP/MECH
<b>Resource Persons</b>	Mr.M.Kannan (United CAD ) Mr.S.Rahul AP/MECH Mr.M.Kannan (United CAD ) Mr. V.K.Vasanth AP/MECH Mr. K.Kavin raj AP/MECH
<b>Duration &amp; Dates</b>	Five days (34 Hours) & 04/12/17 to 08/12/17
<b>Participants &amp; Strength</b>	IV YEAR MECH KSRIET STUDENTS & 80

  
Coordinator

  
Dr. M. VENKATESAN, M.E., Ph.D.,  
PRINCIPAL,  
K S R INSTITUTE FOR  
ENGINEERING AND TECHNOLOGY,  
K.S.R. KALVI NAGAR,  
TIRUCHENGODE-637 215,  
NAMAKKAL Dt, TAMIL NADU.

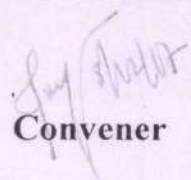
  
Convener

**KSR INSTITUTE FOR ENGINEERING AND TECHNOLOGY  
DEPARTMENT OF MECHANICAL ENGINEERING  
CENTRE FOR VALUE ADDED EDUCATION (CENVAE)**

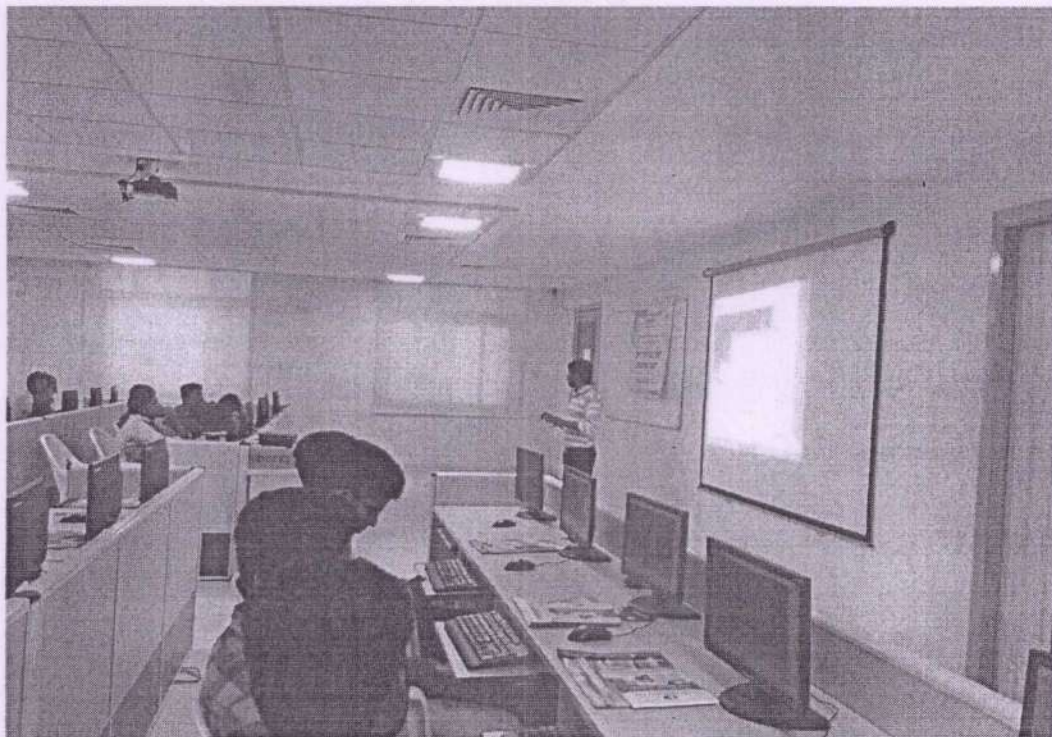
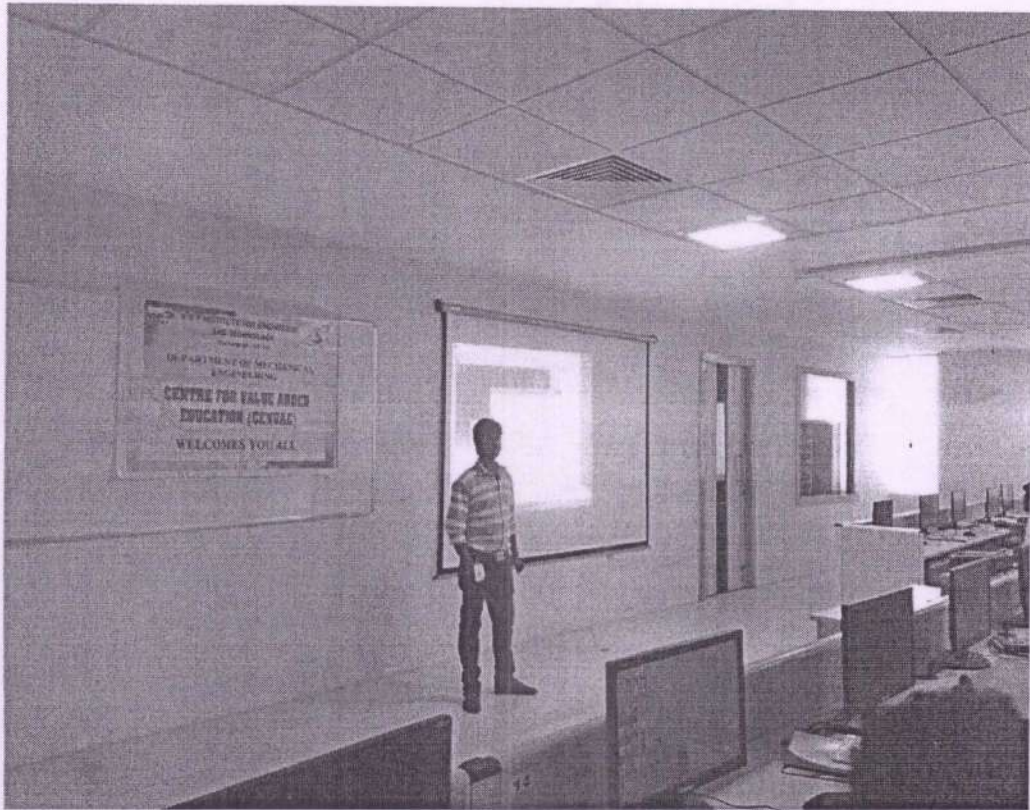

**VALUE ADDED COUSE FOR PIPING**

**Dr. M. VENKATESAN, M.E., Ph.D.,  
PRINCIPAL,  
K S R INSTITUTE FOR  
ENGINEERING AND TECHNOLOGY  
K.S.R. KALVI NAGAR,  
TIRUCHENGODE-637 215  
NAMAKKAL Dt, TAMIL NADU**



www.unitedcaddsolution.com

DESIGN THE FUTURE

**UNITED CADD SOLUTION**

Private Limited

Corporate Office : #516/228-D, Annapuram,  
Junction Main Road,  
Five Roads, Salem, Tamilnadu -636 004.



**KSR Institute For Engineering  
& Technology, Tiruchengode.**



# CERTIFICATE OF EXCELLENCE

Reg. No. : UCS - KSR0026

Awarded to : BHARATHKUMAR P

in : PIPING

at : KSRIET

Duration : 40 Hrs

Grade\* : H\*

Date of Issue : DECEMBER - 2017

\*C : 40-50, D : 50-60, A : 60-75, H : Above 75

*A.V.T. [Signature]*  
**Dr. M. VENKATESAN, M.E., Ph.D.,**  
 PRINCIPAL,  
 KSR INSTITUTE FOR  
 ENGINEERING AND TECHNOLOGY  
 K.S.R. KALVI NAGAR,  
 TIRUCHENGODE-637 215,  
 NAMAKKAL Dt, TAMIL NADU.

*[Signature]*  
 HOD

*[Signature]*  
 Principal



Director